

# Inductive Sensors

## Inductive sensors for object detection

Automation is almost inconceivable without inductive sensors. Wherever processes are automated, non-contact position detection, freedom from wear, and reliability are in demand. Whether in machine building, automation technology, electronics manufacturing or the plastics industry, in textile machines, wood processing or in the automobile industry – Balluff sensors monitor, control and automate processes and states. Providing the highest quality and optimized for any application. From standard to extended switching distance, from temperature and high-pressure resistant to "Factor 1" from mini to maxi: You, too, can take advantage of Balluff's versatility for your applications. And profit from the reliability and quality of proven products from your full-line provider.

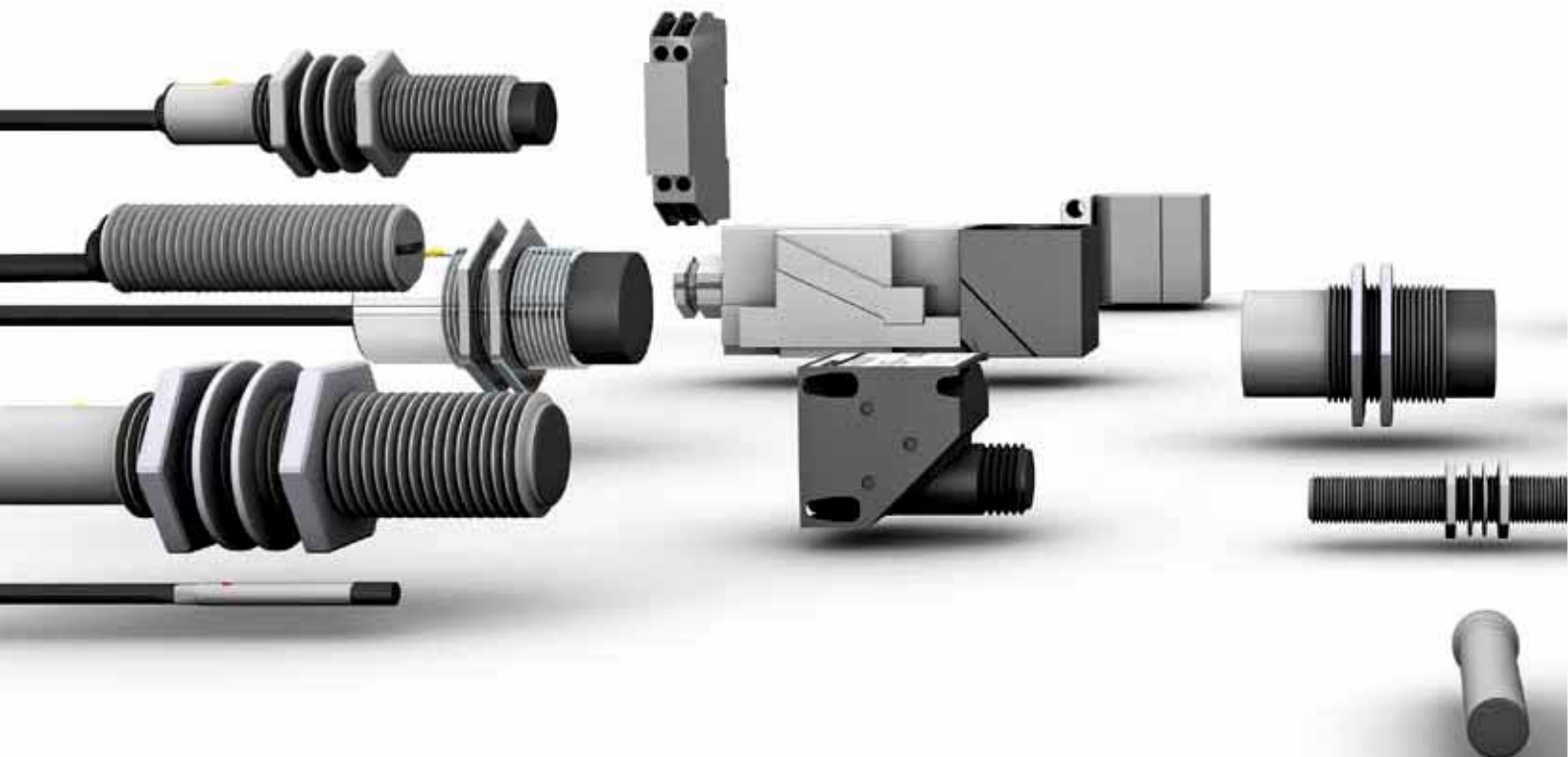

<b>Inductive Sensors</b>			<b>Inductive Sensors with Special Properties</b>	
Performance spectrum	446		High-pressure resistant sensors	618
Product overview	448		Ex sensors	634
			Steelface sensors	640
<b>DC 3-wire Inductive Global Sensors</b>			High temperature rated sensors	646
Cylinder designs	454		Full PTFE sensor	650
			Sensors for the food industry	652
<b>DC 3-/4-wire Inductive Sensors</b>			Factor 1 sensors	662
Cylinder designs	472		Weld and magnetic field immune sensors	674
Block designs	530		Diagnostic sensors	682
			Large designs	688
<b>DC 2-wire Inductive Sensors</b>			Ring sensors	690
Cylinder designs	570		Hose sensors	692
Block designs	582			
			<b>Inductive Sensors for Analog Distance Measurement</b>	
<b>AC/DC 2-wire Inductive Sensors</b>			Cylinder designs	698
Cylinder designs	590		Block designs	709
Block designs	599			
			<b>Accessories for Inductive Sensors</b>	
<b>AC 2-wire Inductive Sensors</b>			Pulse extender	716
Cylinder designs	610		Function diagnostics unit	717
Block designs	615		Sensor tester, testing and setting device	718
			Analog switching amplifiers	720
			Assembly aids for uni and unicomact sensors	722
			Protective coverings for unicomact sensors	725
			Protective end caps	726
			Positive stop	728
			Tube switch	730
			Contact protectors	732

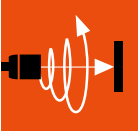

Basic information and definitions can be found on **page 934**.

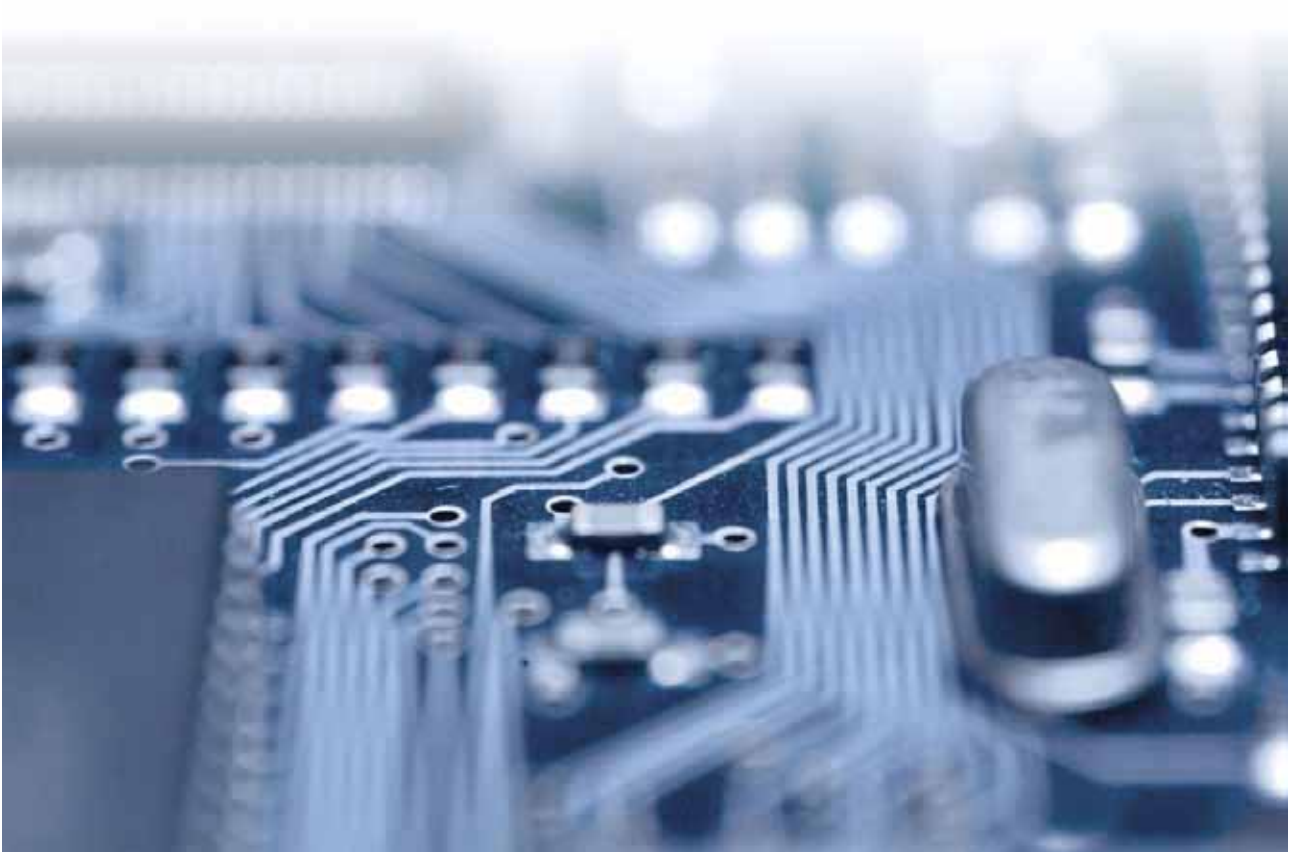

**DC**  
3-/4-Wire

**F1**

**DC**  
2-Wire

PTFE  
Coated  
**Weld**  
Immune

**AC/**  
**DC**  
2-Wire

**500bar**  
High  
Pressure

 **120°C**  
High  
Temperature

**IP68**  
BWN Pr27  
BWN Pr20

**Stainless  
Steel**

# Inductive Sensors

## Performance spectrum

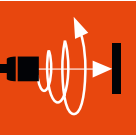
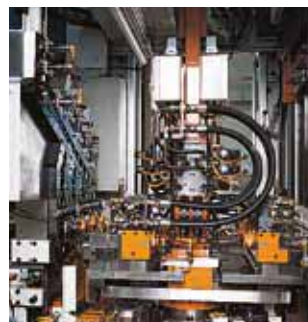

Inductive Sensors  
**Performance Spectrum**  
 Product Overview

Global DC 3-wire

DC 3-/4-wire

DC 2-wire

AC/DC 2-wire

AC 2-wire

Special Properties

Analog Distance measurement

Accessories



# Inductive Sensors

## Product overview



Housing size	Ø 3 mm, Ø 4 mm, M4×0.5	M5×0.5	Ø 6.5 mm, M8×1, Ø 8 mm	M12×1	M16×1	M18×1	
--------------	------------------------------	--------	------------------------------	-------	-------	-------	--

Inductive Sensors							
Global DC 3-wire			Page 455	Page 461		Page 464	
DC 3-/4-wire	Page 473	Page 478	Page 482	Page 508		Page 516	
DC 2-wire			Page 571	Page 574		Page 576	
AC/DC 2-wire				Page 591		Page 592	
AC 2-wire				Page 610		Page 612	

Inductive Sensors with Special Properties							
High-pressure resistant sensors		Page 619 Page 624 Page 625	Page 625	Page 619 Page 620 Page 626	Page 621	Page 622 Page 632	
Ex sensors			Page 638	Page 634 Page 639		Page 635 Page 639	
Steelface sensors			Page 641	Page 642		Page 643	
Temperature-resistant sensors		Page 646	Page 646	Page 646		Page 647	
Full PTFE sensor						Page 651	
Sensors for the food industry				Page 652 Page 657 Page 661		Page 654 Page 657 Page 661	
Factor 1 sensors			Page 663	Page 664		Page 666	
Weld and magnetic field immune sensors				Page 675		Page 677	
Diagnostics sensors				Page 682		Page 683	
Large designs							
Ring sensors							
Hose sensors							

Inductive Sensors for Analog Distance Measurement							
Cylinder designs			Page 698	Page 699		Page 703	
Block designs							
Ring sensors							

# Inductive Sensors

## Product overview



<b>M30×1.5</b>	<b>5×5 mm</b>	<b>8×8 mm</b>	<b>8×16 mm</b> R04	<b>10×30 mm</b> R03	<b>16×30 mm</b>	<b>20×32 mm</b> R01/R06	<b>99×17.6 mm</b>
----------------	---------------	---------------	-----------------------	------------------------	-----------------	----------------------------	-------------------

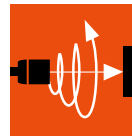

Inductive  
Sensors  
Performance  
Spectrum  
**Product  
Overview**

Global  
DC 3-wire

DC 3-/4-wire

DC 2-wire

AC/DC 2-wire

AC 2-wire

Special  
Properties

Analog  
Distance  
measurement

Accessories

Page 467							
Page 525	Page 531	Page 534	Page 540	Page 542	Page 544	Page 545	
Page 579						Page 582	
Page 595							
Page 613							

Page 639							Page 637
Page 645							
Page 647							
Page 655							
Page 673							
Page 679						Page 681	

Page 706							
				Page 709		Page 710	

# Inductive Sensors

## Product overview



Housing size	25x50 mm	26x26 mm	26x40 mm	42x48 mm	74x60.5 mm	40x40 mm Unicompact	
--------------	----------	----------	----------	----------	------------	------------------------	--

Inductive Sensors							
Global DC 3-wire							
DC 3-/4-wire	Page 546		Page 548	Page 550	Page 551	Page 553	
DC 2-wire		Page 583				Page 584	
AC/DC 2-wire			Page 599			Page 601	
AC 2-wire							

Inductive Sensors with Special Properties							
High-pressure resistant sensors							
Ex sensors						Page 639	
Steelface sensors							
Temperature-resistant sensors	Page 647						
Full PTFE sensor							
Sensors for the food industry							
Factor 1 sensors						Page 671	
Weld and magnetic field immune sensors						Page 681	
Diagnostics sensors						Page 683	
Large designs							
Ring sensors							
Hose sensors							

Inductive Sensors for Analog Distance Measurement							
Cylinder designs							
Block designs							
Ring sensors							

# Inductive Sensors Product overview



	40x40 mm Unisensor	80x80 mm Maxisensor	35x35 mm	Ø 80x67 mm	Ø 110x110 mm	Ring sensors	Hose sensors
	Page 557	Page 564					
	Page 585	Page 586					
	Page 603	Page 607					
		Page 615					
			Page 689	Page 688	Page 689		
						Page 691	
							Page 693
		Page 712					
						Page 713	

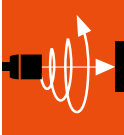

Inductive Sensors  
Performance Spectrum  
Product Overview  
Global DC 3-wire  
DC 3-/4-wire  
DC 2-wire  
AC/DC 2-wire  
AC 2-wire  
Special Properties  
Analog Distance measurement  
Accessories



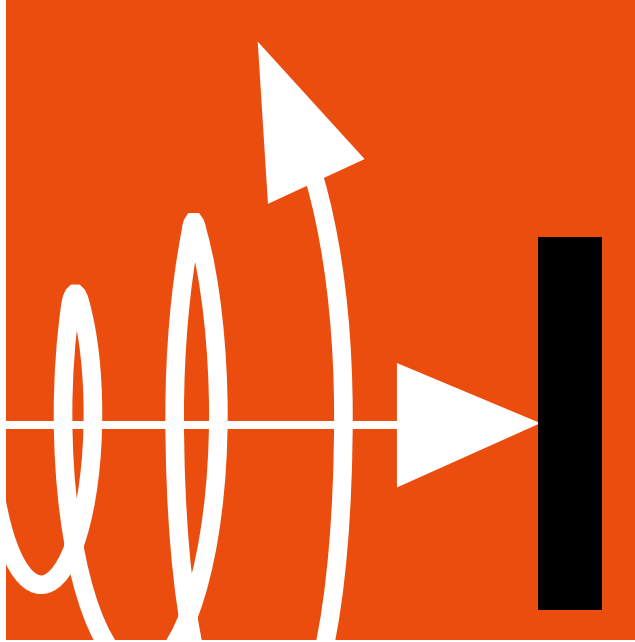

# Inductive Sensors

## DC 3-wire inductive Global sensors

**DC 3-wire inductive Global sensors:** The complete series of standard sensors. Global sensors are the most economical sensors from the Balluff group. These standardized sensors are available at all times and fulfill most tasks excellently.



**Cylinder Designs**

Ø 6.5 mm	455
M8x1	456
M12x1	461
M18x1	464
M30x1.5	467

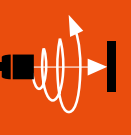

# Global



Basic information and definitions can be found on **page 934**.



# DC 3-wire Inductive Global Sensors

## Cylinder designs

### Global: The complete series of standard sensors

The inductive standard sensors are usually available ex warehouse, can be used globally, are globally standardized and have an optimum price-performance ratio.

- Short and mid-size designs Ø 6.5 mm to M30×1.5
- Shielded and unshielded designs
- Cable and connector versions
- Standard and extended switching distance



Model		
Installation type (observe instructions in the Basic Information chapter)		
Rated switching distance $s_n$		
Assured switching distance $s_a$		
Switching distance marking		
PNP, NO	<b>Ordering code</b>	
	Part number	
PNP, normally closed	<b>Ordering code</b>	
	Part number	
NPN, NO	<b>Ordering code</b>	
	Part number	
NPN, NC	<b>Ordering code</b>	
	Part number	
Supply voltage $U_S$		
Voltage drop $U_d$ at $I_o$ max.		
Rated insulation voltage $U_i$ (protection class)		
Rated operating current $I_o$		
Polarity reversal protected/transposition protected/short-circuit protected		
Ambient temperature $T_a$		
Switching frequency $f$ max.		
Output function indicator		
Degree of protection as per IEC 60529		
Approvals		
Material	Housing	
	Sensing surface	
Connection		

Wiring diagrams, see page 958.

The meaning of switching distance markings can be found on page 962.

**Additional cable lengths and PUR cable jacket material available on request.**



# DC 3-wire Inductive Global Sensors

## Cylinder design, Ø 6.5 mm



Ø 6.5 mm	Ø 6.5 mm	Ø 6.5 mm	Ø 6.5 mm	Ø 6.5 mm
Flush	Flush	Not flush	Not flush	Not flush
<b>2 mm</b>	<b>2 mm</b>	<b>4 mm</b>	<b>4 mm</b>	<b>4 mm</b>
0...1.6 mm	0...1.6 mm	0...3.2 mm	0...3.2 mm	0...3.2 mm
■ ■	■ ■	■ ■	■ ■	■ ■
<b>BES03R9</b>	<b>BES03P4</b>	<b>BES0005</b>	<b>BES03P5</b>	<b>BES000F</b>
BES G06EE-PSC20B-S49G-003	BES G06EH-PSC20B-S49G	BES G06EB-PSC40F-S49G	BES G06EH-PSC40F-S49G	BES G06ED-PSC40F-BV02
<b>BES03RY</b>	<b>BES03RT</b>	<b>BES0004</b>	<b>BES03T1</b>	<b>BES000C</b>
BES G06EE-POC20B-S49G-003	BES G06EH-POC20B-S49G	BES G06EB-POC40F-S49G	BES G06EH-POC40F-S49G	BES G06ED-POC40F-BV02
<b>BES03RZ</b>		<b>BES0003</b>	<b>BES03T2</b>	<b>BES0009</b>
BES G06EE-NSC20B-S49G-003		BES G06EB-NSC40F-S49G	BES G06EH-NSC40F-S49G	BES G06ED-NSC40F-BV02
<b>BES03T0</b>		<b>BES0002</b>	<b>BES03T3</b>	<b>BES0007</b>
BES G06EE-NOC20B-S49G-003		BES G06EB-NOC40F-S49G	BES G06EH-NOC40F-S49G	BES G06ED-NOC40F-BV02
10...30 V DC	10...30 V DC	10...30 V DC	10...30 V DC	10...30 V DC
2.5 V	2.5 V	2.5 V	2.5 V	2.5 V
75 V DC	75 V DC	75 V DC	75 V DC	250 V AC (□)
200 mA	200 mA	200 mA	200 mA	200 mA
Yes/Yes/Yes	Yes/Yes/Yes	Yes/Yes/Yes	Yes/Yes/Yes	Yes/Yes/Yes
-25...70 °C	-25...70 °C	-25...70 °C	-25...70 °C	-25...70 °C
700 Hz	1.5 kHz	1.5 kHz	1.5 kHz	1.5 kHz
Yellow LED	Yellow LED	Yellow LED	Yellow LED	Yellow LED
IP 67	IP 67	IP 67	IP 67	IP 68 per BWN Pr. 20
CE, cULus	CE, cULus	CE, cULus	CE, cULus	CE, cULus
Stainless steel	Stainless steel	Stainless steel	Stainless steel	Stainless steel
PBT	PBT	PA 12	PBT	PBT
M8 connector, 3-pin	M8 connector, 3-pin	M8 connector, 3-pin	M8 connector, 3-pin	2 m PVC cable, 3x0.14 mm <sup>2</sup>

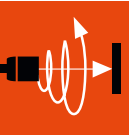

- Inductive Sensors
- Global DC 3-wire
- Cylinder Designs
- DC 3-/4-wire
- DC 2-wire
- AC/DC 2-wire
- AC 2-wire
- Special Properties
- Analog Distance measurement
- Accessories

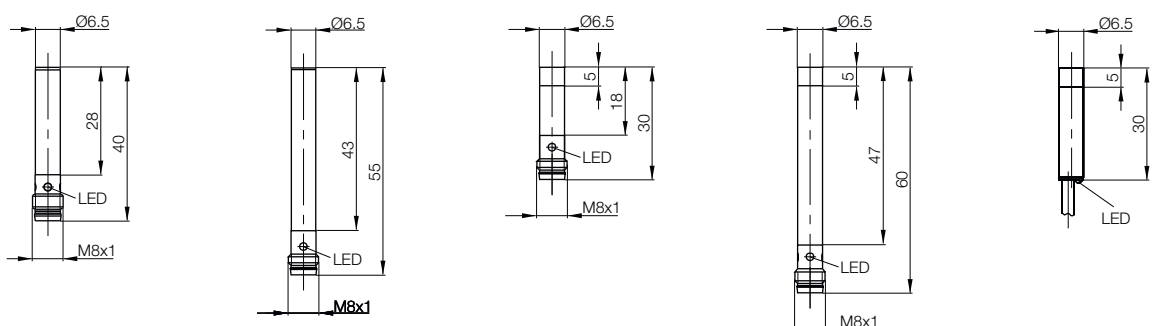



# DC 3-wire Inductive Global Sensors

## Cylinder designs, M8x1



Model		<b>M8x1</b>	<b>M8x1</b>	<b>M8x1</b>
Installation type (observe instructions in the Basic Information chapter)		Flush	Flush	Flush
Rated switching distance $s_n$		<b>1.5 mm</b>	<b>1.5 mm</b>	<b>1.5 mm</b>
Assured switching distance $s_a$		0...1.2 mm	0...1.2 mm	0...1.2 mm
Switching distance marking		■	■	■
PNP, NO	<b>Ordering code</b>	<b>BES00CJ</b>	<b>BES00CH</b>	<b>BES003C</b>
	Part number	BES M08EE-PSC15B-S49G-003	BES M08EE-PSC15B-S04G-003	BES M08MI-PSC15B-S49G
PNP, normally closed	<b>Ordering code</b>	<b>BES00CC</b>	<b>BES00CA</b>	<b>BES03P6</b>
	Part number	BES M08EE-POC15B-S49G-003	BES M08EE-POC15B-S04G-003	BES M08MI-POC15B-S49G
NPN, NO	<b>Ordering code</b>	<b>BES00C7</b>	<b>BES00C6</b>	<b>BES002K</b>
	Part number	BES M08EE-NSC15B-S49G-003	BES M08EE-NSC15B-S04G-003	BES M08MI-NSC15B-S49G
NPN, NC	<b>Ordering code</b>	<b>BES00C3</b>	<b>BES00C2</b>	<b>BES03PK</b>
	Part number	BES M08EE-NOC15B-S49G-003	BES M08EE-NOC15B-S04G-003	BES M08MI-NOC15B-S49G
Supply voltage $U_s$		10...30 V DC	10...30 V DC	12...30 V DC
Voltage drop $U_d$ at $I_e$ max.		2.5 V	2.5 V	2 V
Rated insulation voltage $U_i$ (protection class)		250 V AC (□)	250 V AC (□)	75 V DC
Rated operating current $I_e$		200 mA	200 mA	200 mA
Polarity reversal protected/transposition protected/short-circuit protected		Yes/Yes/Yes	Yes/Yes/Yes	Yes/Yes/Yes
Ambient temperature $T_a$		-25...70 °C	-25...70 °C	-25...70 °C
Switching frequency $f$ max.		1 kHz	1 kHz	1 kHz
Output function indicator		Yellow LED	Yellow LED	Yellow LED
Degree of protection as per IEC 60529		IP 67	IP 67	IP 67
Approvals		CE, cULus	CE, cULus	CE, cULus
Material	Housing	Stainless steel	Stainless steel	Brass-coated
	Sensing surface	PBT	PBT	PA 12
Connection		M8 connector, 3-pin	M12 connector, 4-pin	M8 connector, 3-pin

Wiring diagrams, see page 958.  
The meaning of switching distance markings can be found on page 962.

**Additional cable lengths and PUR cable jacket material available on request.**

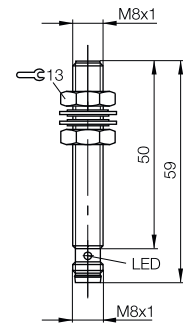
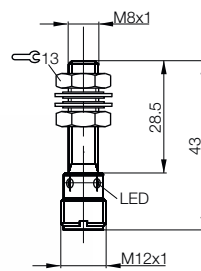
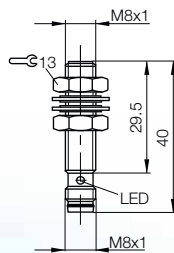

# Global

# DC 3-wire Inductive Global Sensors Cylinder designs, M8x1



M8x1	M8x1	M8x1	M8x1	M8x1
Flush	Flush	Flush	Flush	Flush
<b>1.5 mm</b>	<b>1.5 mm</b>	<b>1.5 mm</b>	<b>2 mm</b>	<b>2 mm</b>
0...1.2 mm	0...1.2 mm	0...1.2 mm	0...1.6 mm	0...1.6 mm
■	■	■	■ ■	■ ■
<b>BES0027</b>	<b>BES00CU</b>	<b>BES0037</b>	<b>BES00CK</b>	<b>BES00FC</b>
BES M08MH1-PSC15B-S04G	BES M08EF-PSC15B-BP02-003	BES M08MI-PSC15B-BV02	BES M08EE-PSC20B-S49G-003	BES M08EE-PSC20B-S04G-003
<b>BES0026</b>	<b>BES00CR</b>	<b>BES0030</b>	<b>BES00CF</b>	<b>BES00CE</b>
BES M08MH1-POC15B-S04G	BES M08EF-POC15B-BP02-003	BES M08MI-POC15B-BV02	BES M08EE-POC20B-S49G-003	BES M08EE-POC20B-S04G-003
<b>BES0024</b>	<b>BES00CN</b>	<b>BES002F</b>	<b>BES00C9</b>	<b>BES00C8</b>
BES M08MH1-NSC15B-S04G	BES M08EF-NSC15B-BP02-003	BES M08MI-NSC15B-BV02	BES M08EE-NSC20B-S49G-003	BES M08EE-NSC20B-S04G-003
<b>BES0023</b>	<b>BES00CL</b>	<b>BES03PJ</b>	<b>BES00C5</b>	<b>BES00C4</b>
BES M08MH1-NOC15B-S04G	BES M08EF-NOC15B-BP02-003	BES M08MI-NOC15B-BV02	BES M08EE-NOC20B-S49G-003	BES M08EE-NOC20B-S04G-003
12...30 V DC	10...30 V DC	12...30 V DC	10...30 V DC	10...30 V DC
2 V	2.5 V	2 V	2.5 V	2.5 V
75 V DC	250 V AC (□)	75 V DC	250 V AC (□)	250 V AC (□)
200 mA	200 mA	200 mA	200 mA	200 mA
Yes/Yes/Yes	Yes/Yes/Yes	Yes/Yes/Yes	Yes/Yes/Yes	Yes/Yes/Yes
-25...70 °C	-25...70 °C	-25...70 °C	-25...70 °C	-25...70 °C
1 kHz	1 kHz	1 kHz	700 Hz	700 Hz
Yellow LED	Yellow LED	Yellow LED	Yellow LED	Yellow LED
IP 67	IP 67	IP 67	IP 67	IP 67
CE, cULus	CE, cULus	CE, cULus	CE, cULus	CE, cULus
Brass-coated	Stainless steel	Brass-coated	Stainless steel	Stainless steel
PA 12	PBT	PA 12	PBT	PBT
M12 connector, 4-pin	2 m PUR cable, 3x0.14 mm <sup>2</sup>	2 m PVC cable, 3x0.14 mm <sup>2</sup>	M8 connector, 3-pin	M12 connector, 4-pin

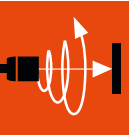

Inductive Sensors  
Global DC 3-wire  
Cylinder Designs  
DC 3-/4-wire  
DC 2-wire  
AC/DC 2-wire  
AC 2-wire  
Special Properties  
Analog Distance measurement  
Accessories

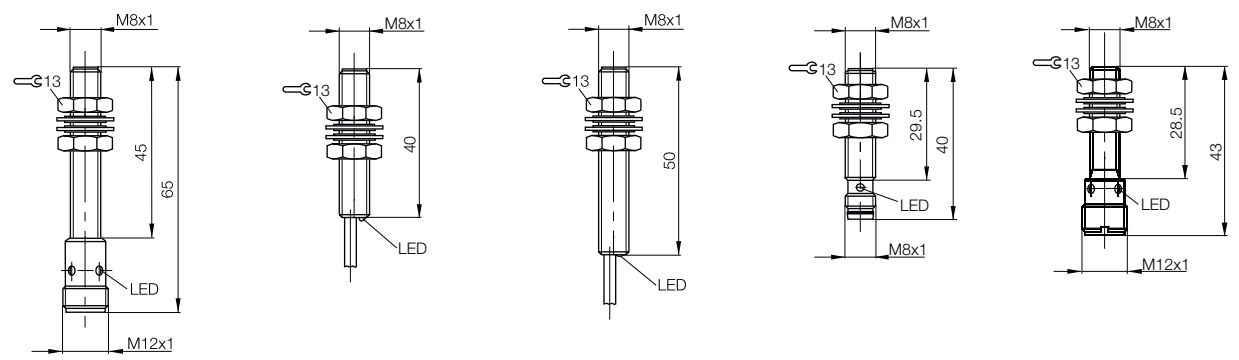

# DC 3-wire Inductive Global Sensors

## Cylinder designs, M8x1



Model		<b>M8x1</b>	<b>M8x1</b>	<b>M8x1</b>	
Installation type (observe instructions in the Basic Information chapter)		Flush	Flush	Flush	
Rated switching distance $s_n$		<b>2 mm</b>	<b>2 mm</b>	<b>2 mm</b>	
Assured switching distance $s_a$		0...1.6 mm	0...1.6 mm	0...1.6 mm	
Switching distance marking		■ ■	■ ■	■ ■	
PNP, NO	<b>Ordering code</b>	<b>BES003P</b>	<b>BES0028</b>		
	Part number	BES M08MI-PSC20B-S49G	BES M08MH1-PSC20B-S04G		
PNP, normally closed	<b>Ordering code</b>	<b>BES0033</b>	<b>BES03T5</b>		
	Part number	BES M08MI-POC20B-S49G	BES M08MH1-POC20B-S04G		
NPN, NO	<b>Ordering code</b>	<b>BES002U</b>	<b>BES0025</b>	<b>BES045P</b>	
	Part number	BES M08MI-NSC20B-S49G	BES M08MH1-NSC20B-S04G	BES M08EF-NSC20B-BP00,3-GS49	
NPN, NC	<b>Ordering code</b>	<b>BES03TJ</b>	<b>BES03T6</b>		
	Part number	BES M08MI-NOC20B-S49G	BES M08MH1-NOC20B-S04G		
Supply voltage $U_s$		12...30 V DC	12...30 V DC	10...30 V DC	
Voltage drop $U_d$ at $I_e$ max.		2.5 V	2.5 V	2.5 V	
Rated insulation voltage $U_i$ (protection class)		75 V DC	75 V DC	250 V AC (□)	
Rated operating current $I_e$		200 mA	200 mA	200 mA	
Polarity reversal protected/transposition protected/short-circuit protected		Yes/Yes/Yes	Yes/Yes/Yes	Yes/Yes/Yes	
Ambient temperature $T_a$		-25...70 °C	-25...70 °C	-25...70 °C	
Switching frequency $f$ max.		700 Hz	700 Hz	700 Hz	
Output function indicator		Yellow LED	Yellow LED	Yellow LED	
Degree of protection as per IEC 60529		IP 67	IP 67	IP 68 per BWN Pr. 20	
Approvals		CE, cULus	CE, cULus	CE, cULus	
Material	Housing	Brass-coated	Brass-coated	Stainless steel	
	Sensing surface	PA 12	PA 12	PBT	
Connection		M8 connector, 3-pin	M12 connector, 4-pin	0.3 m PUR cable with M8 connector, 3-pin	

Wiring diagrams, see page 958.  
The meaning of switching distance markings can be found on page 962.

**Additional cable lengths and PUR cable jacket material available on request.**

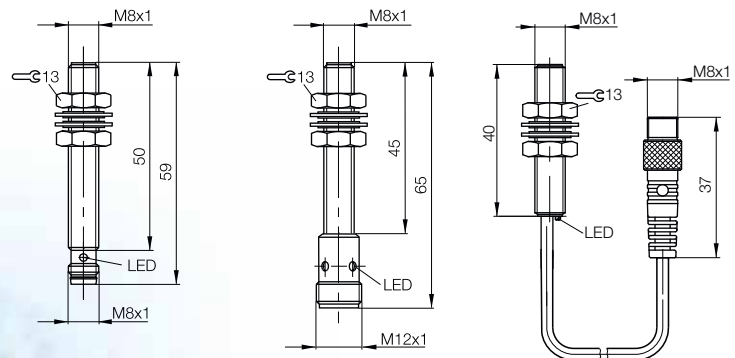

# DC 3-wire Inductive Global Sensors Cylinder designs, M8x1



<b>M8x1</b> Flush <b>2 mm</b> 0...1.6 mm ■■	<b>M8x1</b> Flush <b>2 mm</b> 0...1.6 mm ■■	<b>M8x1</b> Flush <b>2 mm</b> 0...1.6 mm ■■	<b>M8x1</b> Not flush <b>4 mm</b> 0...3.2 mm ■■	<b>M8x1</b> Not flush <b>4 mm</b> 0...3.2 mm ■■
<b>BES003E</b> BES M08MI-PSC20B-BP00,2-GS04	<b>BES00CW</b> BES M08EF-PSC20B-BP02-003	<b>BES003K</b> BES M08MI-PSC20B-BV02	<b>BES000M</b> BES M08EB-PSC40F-S49G	<b>BES001J</b> BES M08EH-PSC40F-S49G
	<b>BES00CT</b> BES M08EF-POC20B-BP02-003	<b>BES03TH</b> BES M08MI-POC20B-BV02	<b>BES000L</b> BES M08EB-POC40F-S49G	<b>BES001F</b> BES M08EH-POC40F-S49G
	<b>BES00CP</b> BES M08EF-NSC20B-BP02-003	<b>BES002P</b> BES M08MI-NSC20B-BV02	<b>BES000K</b> BES M08EB-NSC40F-S49G	<b>BES001C</b> BES M08EH-NSC40F-S49G
	<b>BES00CM</b> BES M08EF-NOC20B-BP02-003	<b>BES03TF</b> BES M08MI-NOC20B-BV02	<b>BES000J</b> BES M08EB-NOC40F-S49G	<b>BES0019</b> BES M08EH-NOC40F-S49G
12...30 V DC 2.5 V 75 V DC 200 mA Yes/Yes/Yes -25...70 °C 700 Hz Yellow LED IP 67 CE, cULus	10...30 V DC 2.5 V 250 V AC (□) 200 mA Yes/Yes/Yes -25...70 °C 700 Hz Yellow LED IP 67 CE, cULus	12...30 V DC 2.5 V 75 V DC 200 mA Yes/Yes/Yes -25...70 °C 700 Hz Yellow LED IP 67 CE, cULus	10...30 V DC 2.5 V 250 V AC (□) 200 mA Yes/Yes/Yes -25...70 °C 1.5 kHz Yellow LED IP 68 per BWN Pr. 20 CE, cULus	10...30 V DC 2.5 V 250 V AC (□) 200 mA Yes/Yes/Yes -25...70 °C 1.5 kHz Yellow LED IP 68 per BWN Pr. 20 CE, cULus
Brass-coated PA 12 0.2 m PUR cable with M12 connector, 4-pin	Stainless steel PBT 2 m PUR cable, 3x0.14 mm <sup>2</sup>	Brass-coated PA 12 2 m PVC cable, 3x0.14 mm <sup>2</sup>	Stainless steel PBT M8 connector, 3-pin	Stainless steel PBT M8 connector, 3-pin

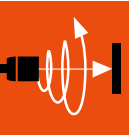

Inductive Sensors  
Global DC 3-wire  
Cylinder Designs  
DC 3-/4-wire  
DC 2-wire  
AC/DC 2-wire  
AC 2-wire  
Special Properties  
Analog Distance measurement  
Accessories

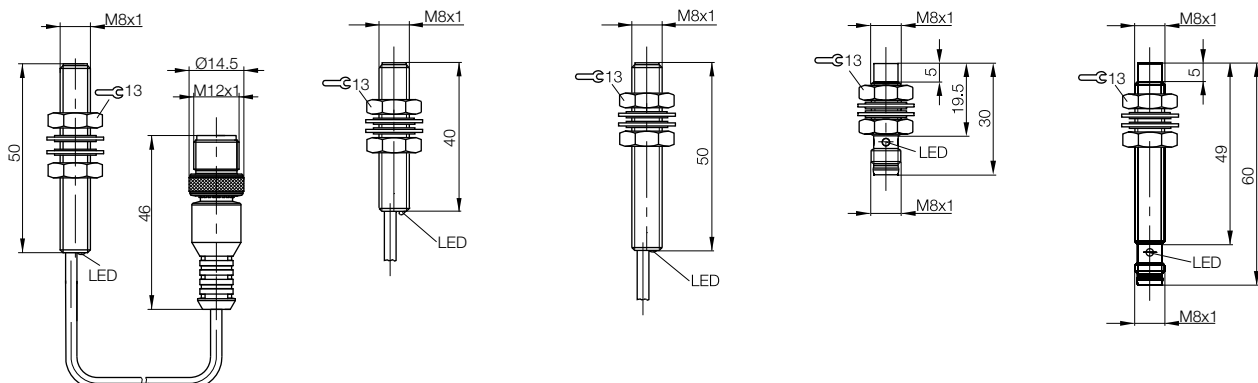



# DC 3-wire Inductive Global Sensors

## Cylinder designs, M8x1



Model		<b>M8x1</b>	<b>M8x1</b>	<b>M8x1</b>
Installation type (observe instructions in the Basic Information chapter)		Not flush	Not flush	Not flush
Rated switching distance $s_n$		<b>4 mm</b>	<b>4 mm</b>	<b>4 mm</b>
Assured switching distance $s_a$		0...3.2 mm	0...3.2 mm	0...3.2 mm
Switching distance marking		■ ■	■ ■	■ ■
PNP, NO	<b>Ordering code</b>	<b>BES001H</b>	<b>BES000Z</b>	<b>BES0017</b>
	Part number	BES M08EH-PSC40F-S04G	BES M08ED-PSC40F-BV02	BES M08EG-PSC40F-BV02
PNP, normally closed	<b>Ordering code</b>	<b>BES001E</b>	<b>BES000W</b>	<b>BES0015</b>
	Part number	BES M08EH-POC40F-S04G	BES M08ED-POC40F-BV02	BES M08EG-POC40F-BV02
NPN, NO	<b>Ordering code</b>	<b>BES001A</b>	<b>BES000T</b>	<b>BES0013</b>
	Part number	BES M08EH-NSC40F-S04G	BES M08ED-NSC40F-BV02	BES M08EG-NSC40F-BV02
NPN, NC	<b>Ordering code</b>	<b>BES0018</b>	<b>BES000P</b>	<b>BES0011</b>
	Part number	BES M08EH-NOC40F-S04G	BES M08ED-NOC40F-BV02	BES M08EG-NOC40F-BV02
Supply voltage $U_s$		10...30 V DC	10...30 V DC	10...30 V DC
Voltage drop $U_d$ at $I_e$ max.		2.5 V	2.5 V	2.5 V
Rated insulation voltage $U_i$ (protection class)		250 V AC (□)	250 V AC (□)	250 V AC (□)
Rated operating current $I_e$		200 mA	200 mA	200 mA
Polarity reversal protected/transposition protected/short-circuit protected		Yes/Yes/Yes	Yes/Yes/Yes	Yes/Yes/Yes
Ambient temperature $T_a$		-25...70 °C	-25...70 °C	-25...70 °C
Switching frequency $f$ max.		1.5 kHz	1.5 kHz	1.5 kHz
Output function indicator		Yellow LED	Yellow LED	Yellow LED
Degree of protection as per IEC 60529		IP 67	IP 68 per BWN Pr. 20	IP 68 per BWN Pr. 20
Approvals		CE, cULus	CE, cULus	CE, cULus
Material	Housing	Stainless steel	Stainless steel	Stainless steel
	Sensing surface	PBT	PA 12	PBT
Connection		M12 connector, 4-pin	2 m PVC cable, 3x0.14 mm <sup>2</sup>	2 m PVC cable, 3x0.14 mm <sup>2</sup>

Wiring diagrams, see page 958.  
The meaning of switching distance markings can be found on page 962.

**Additional cable lengths and PUR cable jacket material available on request.**

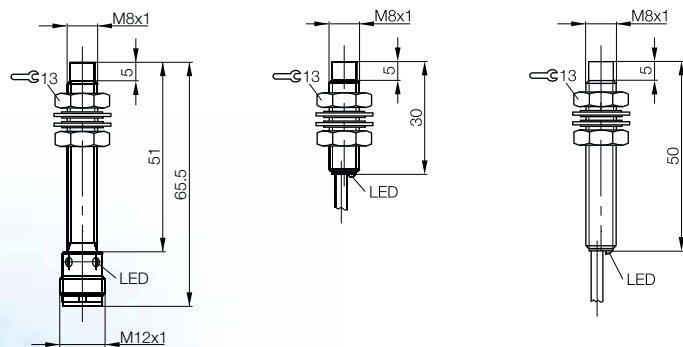

# Global

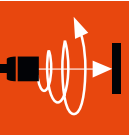

Inductive Sensors

Global DC 3-wire

Cylinder Designs

DC 3-/4-wire

DC 2-wire

AC/DC 2-wire

AC 2-wire

Special Properties

Analog Distance measurement

Accessories



M12x1	M12x1	M12x1	M12x1	M12x1
Flush	Flush	Flush	Flush	Flush
<b>2 mm</b>	<b>2 mm</b>	<b>2 mm</b>	<b>2 mm</b>	<b>4 mm</b>
0...1.6 mm	0...1.6 mm	0...1.6 mm	0...1.6 mm	0...3.2 mm
■	■	■	■	■ ■
<b>BES00EE</b>	<b>BES0060</b>	<b>BES00E4</b>	<b>BES005U</b>	<b>BES00EF</b>
BES M12ME-PSC20B-S04G-003	BES M12MI-PSC20B-S04G	BES M12MD-PSC20B-BP02-003	BES M12MI-PSC20B-BV02	BES M12ME-PSC40B-S04G-003
<b>BES00EA</b>	<b>BES005F</b>	<b>BES00E2</b>	<b>BES00FP</b>	<b>BES00EC</b>
BES M12ME-POC20B-S04G-003	BES M12MI-POC20B-S04G	BES M12MD-POC20B-BP02-003	BES M12MI-POC20B-BV02	BES M12ME-POC40B-S04G-003
<b>BES00E8</b>	<b>BES0054</b>	<b>BES00E0</b>	<b>BES00FL</b>	<b>BES00E9</b>
BES M12ME-NSC20B-S04G-003	BES M12MI-NSC20B-S04G	BES M12MD-NSC20B-BP02-003	BES M12MI-NSC20B-BV02	BES M12ME-NSC40B-S04G-003
<b>BES00E6</b>	<b>BES004Y</b>	<b>BES00CY</b>	<b>BES03PR</b>	<b>BES00E7</b>
BES M12ME-NOC20B-S04G-003	BES M12MI-NOC20B-S04G	BES M12MD-NOC20B-BP02-003	BES M12MI-NOC20B-BV02	BES M12ME-NOC40B-S04G-003
10...30 V DC	12...30 V DC	10...30 V DC	12...30 V DC	10...30 V DC
2 V	2.5 V	2 V	2.5 V	2.5 V
250 V AC (□)	250 V AC (□)	250 V AC (□)	250 V AC (□)	250 V AC (□)
200 mA	200 mA	200 mA	200 mA	200 mA
Yes/Yes/Yes	Yes/Yes/Yes	Yes/Yes/Yes	Yes/Yes/Yes	Yes/Yes/Yes
-25...70 °C	-25...70 °C	-25...70 °C	-25...70 °C	-25...70 °C
1.2 kHz	1.2 kHz	1.2 kHz	1.2 kHz	300 Hz
Yellow LED	Yellow LED	Yellow LED	Yellow LED	Yellow LED
IP 67	IP 68 per BWN Pr. 20	IP 67	IP 68 per BWN Pr. 20	IP 67
CE, cULus	CE, cULus	CE, cULus	CE, cULus	CE, cULus
Brass-coated	Brass-coated	Brass-coated	Brass-coated	Brass-coated
PBT	PA 12	PBT	PA 12	LCP
M12 connector, 4-pin	M12 connector, 4-pin	2 m PUR cable, 3x0.34 mm <sup>2</sup>	2 m PVC cable, 3x0.34 mm <sup>2</sup>	M12 connector, 4-pin

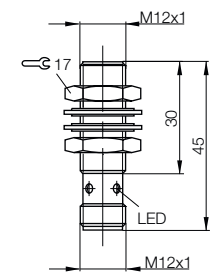
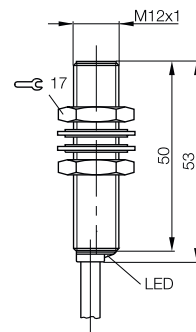
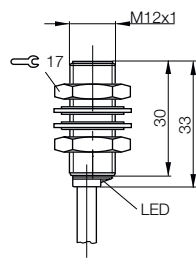
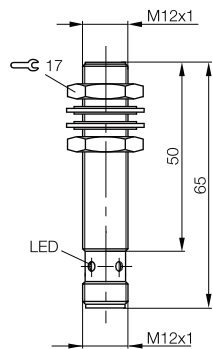
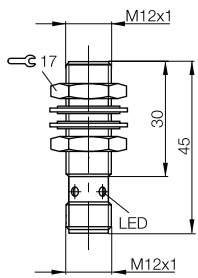

# DC 3-wire Inductive Global Sensors

## Cylinder designs, M12x1



Model		<b>M12x1</b>	<b>M12x1</b>	<b>M12x1</b>
Installation type (observe instructions in the Basic Information chapter)		Flush	Flush	Flush
Rated switching distance $s_n$		<b>4 mm</b>	<b>4 mm</b>	<b>4 mm</b>
Assured switching distance $s_a$		0...3.2 mm	0...3.2 mm	0...3.2 mm
Switching distance marking		■ ■	■ ■	■ ■
PNP, NO	<b>Ordering code</b>	<b>BES0068</b>	<b>BES00E5</b>	<b>BES0064</b>
	Part number	BES M12MI-PSC40B-S04G	BES M12MD-PSC40B-BP02-003	BES M12MI-PSC40B-BV02
PNP, normally closed	<b>Ordering code</b>	<b>BES005N</b>	<b>BES00E3</b>	<b>BES005L</b>
	Part number	BES M12MI-POC40B-S04G	BES M12MD-POC40B-BP02-003	BES M12MI-POC40B-BV02
NPN, NO	<b>Ordering code</b>	<b>BES0059</b>	<b>BES00E1</b>	<b>BES00FM</b>
	Part number	BES M12MI-NSC40B-S04G	BES M12MD-NSC40B-BP02-003	BES M12MI-NSC40B-BV02
NPN, NC	<b>Ordering code</b>	<b>BES004Z</b>	<b>BES00CZ</b>	<b>BES03PT</b>
	Part number	BES M12MI-NOC40B-S04G	BES M12MD-NOC40B-BP02-003	BES M12MI-NOC40B-BV02
Supply voltage $U_s$		12...30 V DC	10...30 V DC	12...30 V DC
Voltage drop $U_d$ at $I_e$ max.		2.5 V	2.5 V	2.5 V
Rated insulation voltage $U_i$ (protection class)		250 V AC (□)	250 V AC (□)	250 V AC (□)
Rated operating current $I_e$		200 mA	200 mA	200 mA
Polarity reversal protected/transposition protected/short-circuit protected		Yes/Yes/Yes	Yes/Yes/Yes	Yes/Yes/Yes
Ambient temperature $T_a$		-25...70 °C	-25...70 °C	-25...70 °C
Switching frequency $f$ max.		500 Hz	300 Hz	500 Hz
Output function indicator		Yellow LED	Yellow LED	Yellow LED
Degree of protection as per IEC 60529		IP 68 per BWN Pr. 20	IP 67	IP 68 per BWN Pr. 20
Approvals		CE, cULus	CE, cULus	CE, cULus
Material	Housing	Brass-coated	Brass-coated	Brass-coated
	Sensing surface	PA 12	LCP	PA 12
Connection		M12 connector, 4-pin	2 m PUR cable, 3x0.34 mm <sup>2</sup>	2 m PVC cable, 3x0.34 mm <sup>2</sup>

Wiring diagrams, see page 958.  
The meaning of switching distance markings can be found on page 962.

**Additional cable lengths and PUR cable jacket material available on request.**

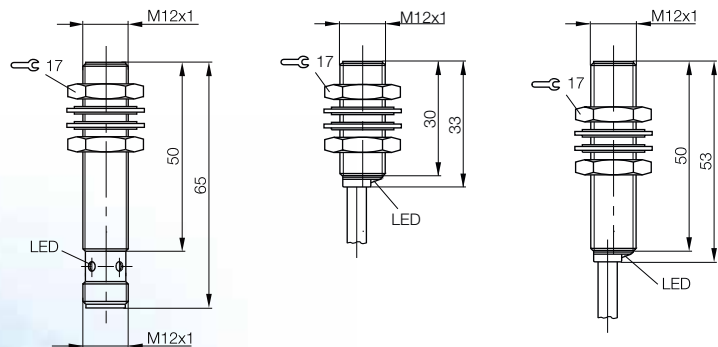

# Global



M12x1	M12x1	M12x1		
Not flush	Not flush	Not flush		
<b>8 mm</b>	<b>8 mm</b>	<b>8 mm</b>		
0...6.4 mm	0...6.4 mm	0...6.4 mm		
■ ■	■ ■	■ ■		
<b>BES01PY</b>	<b>BES004N</b>	<b>BES004M</b>		
BES M12MD-PSC80F-S04G	BES M12MG-PSC80F-S04G	BES M12MG-PSC80F-BV02		
<b>BES01PU</b>	<b>BES004K</b>	<b>BES004J</b>		
BES M12MD-POC80F-S04G	BES M12MG-POC80F-S04G	BES M12MG-POC80F-BV02		
<b>BES01PT</b>	<b>BES004F</b>	<b>BES004E</b>		
BES M12MD-NSC80F-S04G	BES M12MG-NSC80F-S04G	BES M12MG-NSC80F-BV02		
<b>BES01PR</b>	<b>BES004A</b>	<b>BES0049</b>		
BES M12MD-NOC80F-S04G	BES M12MG-NOC80F-S04G	BES M12MG-NOC80F-BV02		
10...30 V DC	10...30 V DC	10...30 V DC		
2.5 V	2.5 V	2.5 V		
250 V AC (□)	250 V AC (□)	250 V AC (□)		
200 mA	200 mA	200 mA		
Yes/Yes/Yes	Yes/Yes/Yes	Yes/Yes/Yes		
-25...70 °C	-25...70 °C	-25...70 °C		
800 Hz	800 Hz	800 Hz		
Yellow LED	Yellow LED	Yellow LED		
IP 68 per BWN Pr. 20	IP 67	IP 67		
CE, cULus	CE, cULus	CE, cULus		
Brass-coated	Brass-coated	Brass-coated		
PBT	PBT	PBT		
M12 connector, 4-pin	M12 connector, 4-pin	2 m PVC cable, 3x0.34 mm <sup>2</sup>		

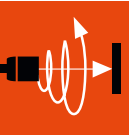

Inductive Sensors

Global DC 3-wire

Cylinder Designs

DC 3-/4-wire

DC 2-wire

AC/DC 2-wire

AC 2-wire

Special Properties

Analog Distance measurement

Accessories

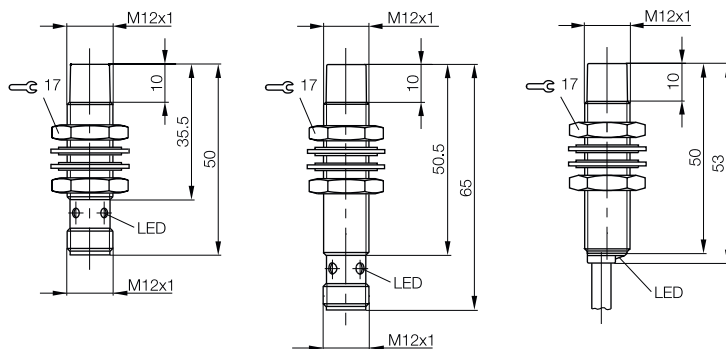

# DC 3-wire Inductive Global Sensors

## Cylinder designs, M18x1



Model		<b>M18x1</b>	<b>M18x1</b>	<b>M18x1</b>
Installation type (observe instructions in the Basic Information chapter)		Flush	Flush	Flush
Rated switching distance $s_n$		<b>5 mm</b>	<b>5 mm</b>	<b>5 mm</b>
Assured switching distance $s_a$		0...4 mm	0...4 mm	0...4 mm
Switching distance marking		■	■	■
PNP, NO	<b>Ordering code</b>	<b>BES00EY</b>	<b>BES0086</b>	<b>BES00EN</b>
	Part number	BES M18ME-PSC50B-S04G-003	BES M18MI-PSC50B-S04G	BES M18MD-PSC50B-BP02-003
PNP, normally closed	<b>Ordering code</b>	<b>BES00EU</b>	<b>BES043J</b>	<b>BES00EL</b>
	Part number	BES M18ME-POC50B-S04G-003	BES M18MI-POC50B-S04G	BES M18MD-POC50B-BP02-003
NPN, NO	<b>Ordering code</b>	<b>BES00ER</b>		<b>BES00EJ</b>
	Part number	BES M18ME-NSC50B-S04G-003		BES M18MD-NSC50B-BP02-003
NPN, NC	<b>Ordering code</b>	<b>BES03T7</b>		<b>BES03T8</b>
	Part number	BES M18ME-NOC50B-S04G-003		BES M18MD-NOC50B-BP02-003
Supply voltage $U_s$		10...30 V DC	12...30 V DC	10...30 V DC
Voltage drop $U_d$ at $I_o$ max.		2 V	2.5 V	2 V
Rated insulation voltage $U_i$ (protection class)		75 V DC	250 V AC (II)	75 V DC
Rated operating current $I_o$		200 mA	200 mA	200 mA
Polarity reversal protected/transposition protected/short-circuit protected		Yes/Yes/Yes	Yes/Yes/Yes	Yes/Yes/Yes
Ambient temperature $T_a$		-25...70 °C	-25...70 °C	-25...70 °C
Switching frequency $f$ max.		700 Hz	700 Hz	700 Hz
Output function indicator		Yellow LED	Yellow LED	Yellow LED
Degree of protection as per IEC 60529		IP 67	IP 68 per BWN Pr. 20	IP 67
Approvals		CE, cULus	CE, cULus	CE, cULus
Material	Housing	Brass-coated	Brass-coated	Brass-coated
	Sensing surface	PA 12	PA 12	PA 12
Connection		M12 connector, 4-pin	M12 connector, 4-pin	2 m PUR cable, 3x0.34 mm <sup>2</sup>

Wiring diagrams, see page 958.  
The meaning of switching distance markings can be found on page 962.

**Additional cable lengths and PUR cable jacket material available on request.**

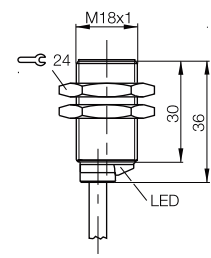
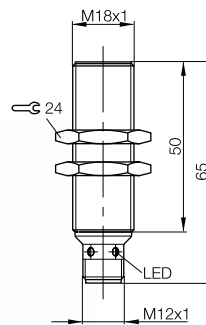
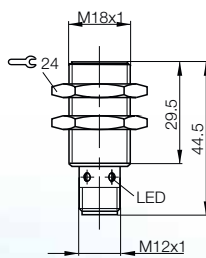

# Global

# DC 3-wire Inductive Global Sensors Cylinder designs, M18x1

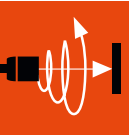

Inductive Sensors

Global DC 3-wire

Cylinder Designs

DC 3-/4-wire

DC 2-wire

AC/DC 2-wire

AC 2-wire

Special Properties

Analog Distance measurement

Accessories



M18x1	M18x1	M18x1	M18x1	M18x1
Flush	Flush	Flush	Flush	Flush
<b>5 mm</b>	<b>8 mm</b>	<b>8 mm</b>	<b>8 mm</b>	<b>8 mm</b>
0...4 mm	0...6.4 mm	0...6.4 mm	0...6.4 mm	0...6.4 mm
■	■ ■	■ ■	■ ■	■ ■
<b>BES0082</b>	<b>BES00EZ</b>	<b>BES008L</b>	<b>BES00EP</b>	<b>BES008E</b>
BES M18MI-PSC50B-BV02	BES M18ME-PSC80B-S04G-003	BES M18MI-PSC80B-S04G	BES M18MD-PSC80B-BP02-003	BES M18MI-PSC80B-BV02
<b>BES007R</b>	<b>BES00EW</b>	<b>BES03RP</b>	<b>BES00EM</b>	<b>BES03PY</b>
BES M18MI-POC50B-BV02	BES M18ME-POC80B-S04G-003	BES M18MI-POC80B-S04G	BES M18MD-POC80B-BP02-003	BES M18MI-POC80B-BV02
<b>BES007A</b>	<b>BES00ET</b>	<b>BES007L</b>	<b>BES00EK</b>	<b>BES00FE</b>
BES M18MI-NSC50B-BV02	BES M18ME-NSC80B-S04G-003	BES M18MI-NSC80B-S04G	BES M18MD-NSC80B-BP02-003	BES M18MI-NSC80B-BV02
<b>BES03RR</b>	<b>BES03RN</b>	<b>BES0077</b>	<b>BES00EH</b>	<b>BES03T4</b>
BES M18MI-NOC50B-BV02	BES M18ME-NOC80B-S04G-003	BES M18MI-NOC80B-S04G	BES M18MD-NOC80B-BP02-003	BES M18MI-NOC80B-BV02
12...30 V DC	10...30 V DC	10...30 V DC	10...30 V DC	12...30 V DC
2.5 V	3.5 V	2.5 V	3.5 V	2.5 V
250 V AC (□)	75 V DC	250 V AC (□)	75 V DC	250 V AC (□)
200 mA	130 mA	200 mA	130 mA	200 mA
Yes/Yes/Yes	Yes/Yes/Yes	Yes/Yes/Yes	Yes/Yes/Yes	Yes/Yes/Yes
-25...70 °C	-25...70 °C	-25...70 °C	-25...70 °C	-25...70 °C
700 Hz	150 Hz	1 kHz	150 Hz	150 Hz
Yellow LED	Yellow LED	Yellow LED	Yellow LED	Yellow LED
IP 68 per BWN Pr. 20	IP 67	IP 67	IP 67	IP 68 per BWN Pr. 20
CE, cULus	CE, cULus	CE, cULus	CE, cULus	CE, cULus
Brass-coated	Brass-coated	Brass-coated	Brass-coated	Brass-coated
PA 12	PBT	PBT	PBT	PA 12
2 m PVC cable, 3x0.34 mm <sup>2</sup>	M12 connector, 4-pin	M12 connector, 4-pin	2 m PUR cable, 3x0.34 mm <sup>2</sup>	2 m PVC cable, 3x0.34 mm <sup>2</sup>

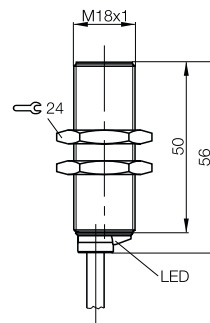
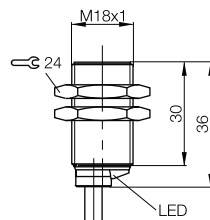
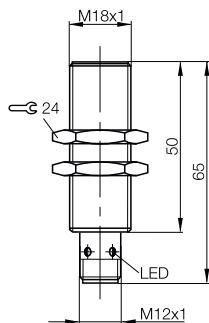
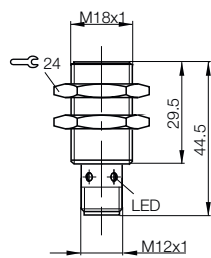
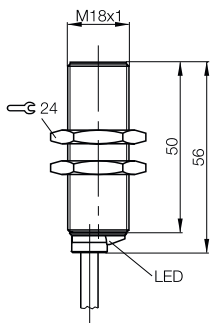



# DC 3-wire Inductive Global Sensors

## Cylinder designs, M18x1



Model		<b>M18x1</b>	<b>M18x1</b>	
Installation type (observe instructions in the Basic Information chapter)		Not flush	Not flush	
Rated switching distance $s_n$		<b>16 mm</b>	<b>16 mm</b>	
Assured switching distance $s_a$		0...13 mm	0...13 mm	
Switching distance marking		■ ■	■ ■	
PNP, NO	<b>Ordering code</b>	<b>BES03RM</b>	<b>BES006Z</b>	
	Part number	BES M18MG-PSC16F-S04G	BES M18MG-PSC16F-BV02	
PNP, normally closed	<b>Ordering code</b>	<b>BES03RL</b>	<b>BES006U</b>	
	Part number	BES M18MG-POC16F-S04G	BES M18MG-POC16F-BV02	
NPN, NO	<b>Ordering code</b>		<b>BES006P</b>	
	Part number		BES M18MG-NSC16F-BV02	
NPN, NC	<b>Ordering code</b>		<b>BES006L</b>	
	Part number		BES M18MG-NOC16F-BV02	
Supply voltage $U_s$		10...30 V DC	10...30 V DC	
Voltage drop $U_d$ at $I_o$ max.		2.5 V	2.5 V	
Rated insulation voltage $U_i$ (protection class)		75 V DC (□)	250 V AC (□)	
Rated operating current $I_o$		200 mA	200 mA	
Polarity reversal protected/transposition protected/short-circuit protected		Yes/Yes/Yes	Yes/Yes/Yes	
Ambient temperature $T_a$		-25...70 °C	-25...70 °C	
Switching frequency $f$ max.		800 Hz	800 Hz	
Output function indicator		Yellow LED	Yellow LED	
Degree of protection as per IEC 60529		IP 67	IP 67	
Approvals		CE, cULus	CE, cULus	
Material	Housing	Brass-coated	Brass-coated	
	Sensing surface	PBT	PBT	
Connection		M12 connector, 4-pin	2 m PVC cable, 3x0.34 mm <sup>2</sup>	

Wiring diagrams, see page 958.  
The meaning of switching distance markings can be found on page 962.

**Additional cable lengths and PUR cable jacket material available on request.**

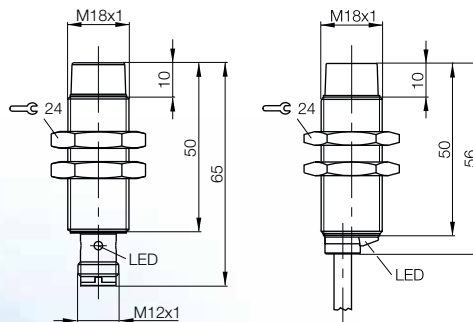



M30×1.5	M30×1.5	M30×1.5	M30×1.5	M30×1.5
Flush	Flush	Flush	Flush	Flush
<b>10 mm</b>	<b>10 mm</b>	<b>10 mm</b>	<b>10 mm</b>	<b>10 mm</b>
0...8 mm	0...8.1 mm	0...8.1 mm	0...8.1 mm	0...8.1 mm
■	■	■	■	■
<b>BES00F8</b>	<b>BES00A4</b>	<b>BES00A3</b>	<b>BES00F3</b>	<b>BES00A0</b>
BES M30ME-PSC10B-S04G-003	BES M30MI-PSC10B-S04K	BES M30MI-PSC10B-S04G	BES M30MD-PSC10B-BP02-003	BES M30MI-PSC10B-BV02
<b>BES00F6</b>	<b>BES009P</b>	<b>BES043H</b>	<b>BES03TC</b>	<b>BES009M</b>
BES M30ME-POC10B-S04G-003	BES M30MI-POC10B-S04K	BES M30MI-POC10B-S04G	BES M30MD-POC10B-BP02-003	BES M30MI-POC10B-BV02
<b>BES00F5</b>	<b>BES009H</b>		<b>BES00F0</b>	<b>BES009C</b>
BES M30ME-NSC10B-S04G-003	BES M30MI-NSC10B-S04K		BES M30MD-NSC10B-BP02-003	BES M30MI-NSC10B-BV02
<b>BES03TA</b>	<b>BES0097</b>		<b>BES03TE</b>	<b>BES0096</b>
BES M30ME-NOC10B-S04G-003	BES M30MI-NOC10B-S04K		BES M30MD-NOC10B-BP02-003	BES M30MI-NOC10B-BV02
10...30 V DC	12...30 V DC	12...30 V DC	10...30 V DC	12...30 V DC
3.5 V	2.5 V	2.5 V	3.5 V	2.5 V
75 V DC	250 V AC (□)	75 V DC	75 V DC	250 V AC (□)
130 mA	200 mA	200 mA	130 mA	200 mA
Yes/Yes/Yes	Yes/Yes/Yes	Yes/Yes/Yes	Yes/Yes/Yes	Yes/Yes/Yes
-25...70 °C	-25...70 °C	-25...70 °C	-25...70 °C	-25...70 °C
150 Hz	400 Hz	400 Hz	150 Hz	400 Hz
Yellow LED	Yellow LED	Yellow LED	Yellow LED	Yellow LED
IP 67	IP 68 per BWN Pr. 20	IP 67	IP67	IP 68 per BWN Pr. 20
CE, cULus	CE, cULus	CE, cULus	CE, cULus	CE, cULus
Brass-coated	Brass-coated	Brass-coated	Brass-coated	Brass-coated
PA 12	PA 12	PA 12	PA 12	PA 12
M12 connector, 4-pin	M12 connector, 4-pin	M12 connector, 4-pin	2 m PUR cable, 3×0.34 mm <sup>2</sup>	2 m PVC cable, 3×0.34 mm <sup>2</sup>

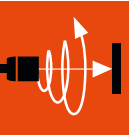

Inductive Sensors  
Global DC 3-wire  
Cylinder Designs  
DC 3-/4-wire  
DC 2-wire  
AC/DC 2-wire  
AC 2-wire  
Special Properties  
Analog Distance measurement  
Accessories

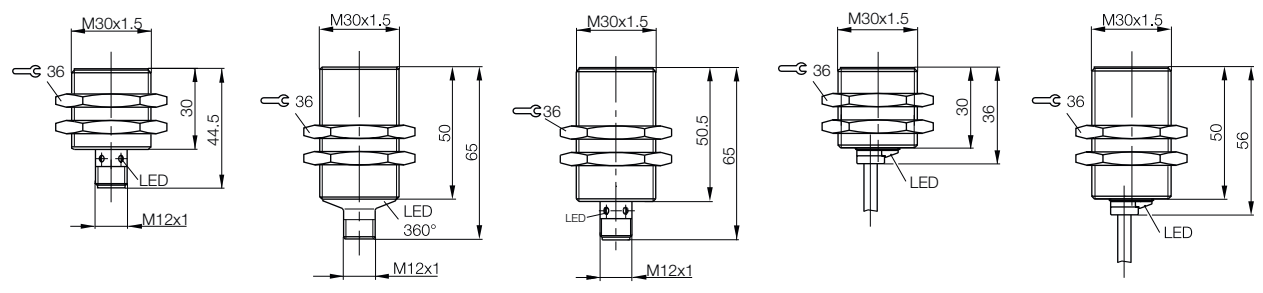

# DC 3-wire Inductive Global Sensors

## Cylinder designs, M30x1.5



Model		<b>M30x1.5</b>	<b>M30x1.5</b>	<b>M30x1.5</b>
Installation type (observe instructions in the Basic Information chapter)		Flush	Flush	Flush
Rated switching distance $s_n$		<b>15 mm</b>	<b>15 mm</b>	<b>15 mm</b>
Assured switching distance $s_a$		0...12 mm	0...12.2 mm	0...12.2 mm
Switching distance marking		■ ■	■ ■	■ ■
PNP, NO	<b>Ordering code</b>	<b>BES00F9</b>	<b>BES00AH</b>	<b>BES00AF</b>
	Part number	BES M30ME-PSC15B-S04G-003	BES M30MI-PSC15B-S04K	BES M30MI-PSC15B-S04G
PNP, normally closed	<b>Ordering code</b>	<b>BES00F7</b>	<b>BES009U</b>	<b>BES03RK</b>
	Part number	BES M30ME-POC15B-S04G-003	BES M30MI-POC15B-S04K	BES M30MI-POC15B-S04G
NPN, NO	<b>Ordering code</b>		<b>BES009J</b>	
	Part number		BES M30MI-NSC15B-S04K	
NPN, NC	<b>Ordering code</b>		<b>BES0098</b>	
	Part number		BES M30MI-NOC15B-S04K	
Supply voltage $U_s$		10...30 V DC	10...30 V DC	10...30 V DC
Voltage drop $U_d$ at $I_e$ max.		3.5 V	2.5 V	2.5 V
Rated insulation voltage $U_i$ (protection class)		75 DC	250 V AC (□)	250 V AC (□)
Rated operating current $I_e$		130 mA	200 mA	200 mA
Polarity reversal protected/transposition protected/short-circuit protected		Yes/Yes/Yes	Yes/Yes/Yes	Yes/Yes/Yes
Ambient temperature $T_a$		-25...70 °C	-25...70 °C	-25...70 °C
Switching frequency $f$ max.		75 Hz	100 Hz	100 Hz
Output function indicator		Yellow LED	Yellow LED	Yellow LED
Degree of protection as per IEC 60529		IP 67	IP 67	IP 67
Approvals		CE, cULus	CE, cULus	CE, cULus
Material	Housing	Brass-coated	Brass-coated	Brass-coated
	Sensing surface	PA 12	PA 12	PA 12
Connection		M12 connector, 4-pin	M12 connector, 4-pin	M12 connector, 4-pin

Wiring diagrams, see page 958.  
The meaning of switching distance markings can be found on page 962.

**Additional cable lengths and PUR cable jacket material available on request.**

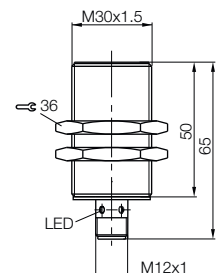
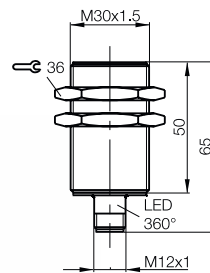
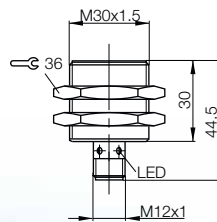

# DC 3-wire Inductive Global Sensors

## Cylinder designs, M30x1.5



M30x1.5	M30x1.5	M30x1.5	M30x1.5	M30x1.5
Flush	Flush	Not flush	Not flush	Not flush
<b>15 mm</b>	<b>15 mm</b>	<b>30 mm</b>	<b>30 mm</b>	<b>30 mm</b>
0...12 mm	0...12.2 mm	0...24 mm	0...24 mm	0...24 mm
■ ■	■ ■	■ ■	■ ■	■ ■
<b>BES00F4</b>	<b>BES00AA</b>	<b>BES00AZ</b>	<b>BES03RE</b>	<b>BES00AY</b>
BES M30MD-PSC15B-BP02-003	BES M30MI-PSC15B-BV02	BES M30MM-PSC30F-S04K	BES M30MM-PSC30F-S04G	BES M30MM-PSC30F-BV02
<b>BES00F2</b>	<b>BES009T</b>	<b>BES00AU</b>	<b>BES03RC</b>	<b>BES00AT</b>
BES M30MD-POC15B-BP02-003	BES M30MI-POC15B-BV02	BES M30MM-POC30F-S04K	BES M30MM-POC30F-S04G	BES M30MM-POC30F-BV02
<b>BES00F1</b>	<b>BES03RH</b>	<b>BES00AP</b>		<b>BES00AN</b>
BES M30MD-NSC15B-BP02-003	BES M30MI-NSC15B-BV02	BES M30MM-NSC30F-S04K		BES M30MM-NSC30F-BV02
	<b>BES03RJ</b>	<b>BES00AL</b>		<b>BES00AK</b>
	BES M30MI-NOC15B-BV02	BES M30MM-NOC30F-S04K		BES M30MM-NOC30F-BV02
10...30 V DC	10...30 V DC	10...30 V DC	10...30 V DC	10...30 V DC
3.5 V	2.5 V	2.5 V	2.5 V	2.5 V
75 V DC	250 V AC (□)	250 V AC (□)	250 V AC (□)	250 V AC (□)
130 mA	200 mA	200 mA	200 mA	200 mA
Yes/Yes/Yes	Yes/Yes/Yes	Yes/Yes/Yes	Yes/Yes/Yes	Yes/Yes/Yes
-25...70 °C	-25...70 °C	-25...70 °C	-25...70 °C	-25...70 °C
75 Hz	100 Hz	300 Hz	300 Hz	300 Hz
Yellow LED	Yellow LED	Yellow LED	Yellow LED	Yellow LED
IP 67	IP 67	IP 67	IP 67	IP 67
CE, cULus	CE, cULus	CE, cULus	CE, cULus	CE, cULus
Brass-coated	Brass-coated	Brass-coated	Brass-coated	Brass-coated
PA 12	PA 12	PBT	PBT	PBT
2 m PUR cable, 3x0.34 mm <sup>2</sup>	2 m PVC cable, 3x0.34 mm <sup>2</sup>	M12 connector, 4-pin	M12 connector, 4-pin	2 m PVC cable, 3x0.34 mm <sup>2</sup>

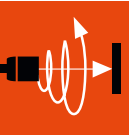

- Inductive Sensors
- Global DC 3-wire
- Cylinder Designs
- DC 3-/4-wire
- DC 2-wire
- AC/DC 2-wire
- AC 2-wire
- Special Properties
- Analog Distance measurement
- Accessories

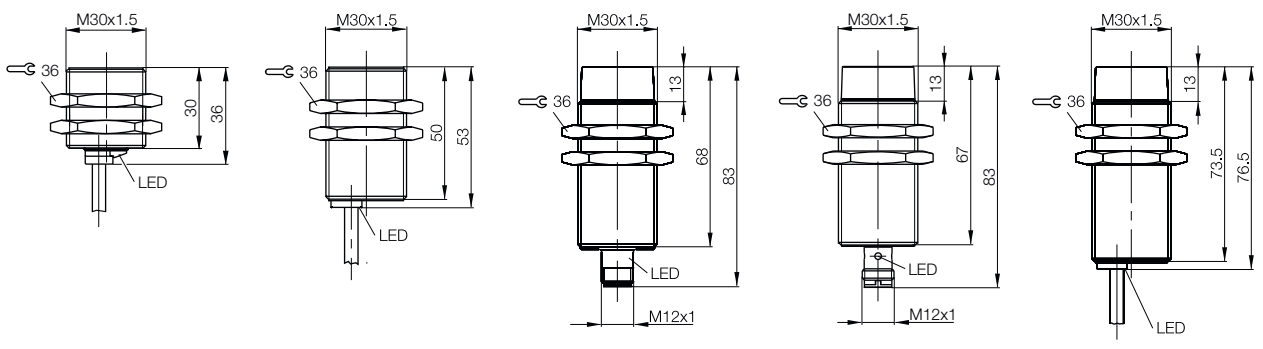

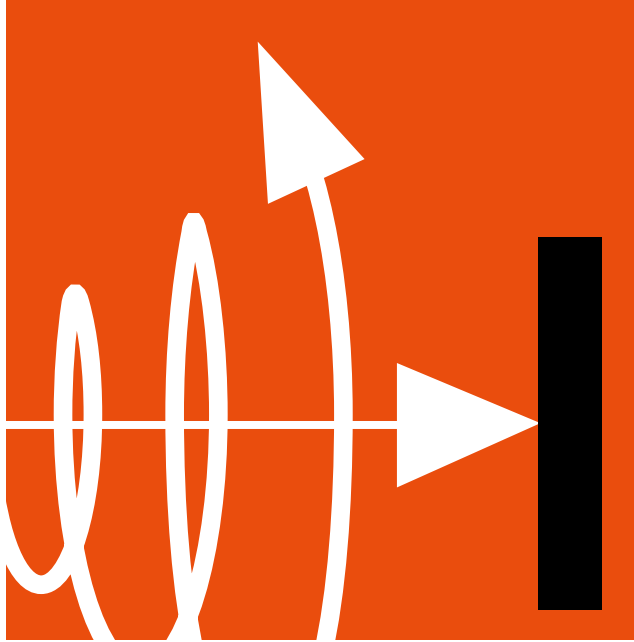

# Inductive Sensors

## DC 3-/4-wire inductive sensors

### **Our standard product line in 3- and 4-wire DC technology**

Balluff offers something for everyone with this comprehensive product line of sensors from  $\varnothing$  3 mm to 80x80 mm for practically every application in automation. These high-quality sensors are designed and manufactured according to worldwide standards and the latest technology. Our 100 % final inspection of all products guarantees that only carefully tested sensors leave our plants.



**Cylinder Designs**

Ø 3 mm	473
Ø 4 mm	474
M5x0.5	478
Ø 6.5 mm	482
Ø 8 mm	490
M8x1	491
M12x1	508
M18x1	516
M30x1.5	525

**Block Designs**

5x5 mm	531
8x8 mm	534
8x16x4 mm (R04)	540
10x30x6 mm (R03)	542
30x20x10 mm	543
16x30x10 mm	544
20x32x8 mm (R01)	545
20x50x10 mm	546
26x40x12 mm (R05)	548
42x48x22 mm	550
74x60.5x28 mm	551
40x40 mm (Unicompact)	553
40x40 mm (Unisensor)	557
80x80 mm (Maxisensor)	564

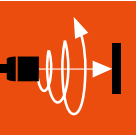

Basic information and definitions can be found on **page 934**.



## DC 3-/4-wire Inductive Sensors

### Inductive mini-sensors

#### High-performance and compact

Inductive mini-sensors guarantee position sensing in rough environments, and stand out due to an optimum price/performance ratio. They are easy to install and can be fully integrated even in narrow assemblies such as linear units, valves and actuators. As a result, position sensing is now possible where there was never space for a sensor before. Modules can be made even smaller. The low weight of the mini-sensors allows applications with extremely fast acceleration, so that pick-and-place is easy to manage.



#### SuperShorties and slim designs

Inductive mini-sensors come with an especially small diameter: 3 mm, 4 mm and 5 mm. And they are available as compact SuperShorties with a housing length of just 6 mm. They are the shortest inductive sensors on the market.

- The most compact on the market: can be fully integrated
- Unmatched in thinness and, as SuperShorty, unmatched in their short length
- Low weight (0.7 g) for extreme accelerations





# DC 3-/4-wire Inductive Sensors

## Cylinder designs, Ø 3 mm

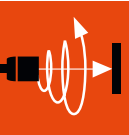

Inductive Sensors

Global DC 3-wire

DC 3-/4-wire

Cylinder Designs

Block Designs

DC 2-wire

AC/DC 2-wire

AC 2-wire

Special Properties

Analog Distance measurement

Special accessories

Model		Ø 3 mm	Ø 3 mm	Ø 3 mm
Installation type (observe instructions in the Basic Information chapter)		Flush	Flush	Flush
Rated switching distance $s_n$		<b>1 mm</b>	<b>1 mm</b>	<b>1 mm</b>
Assured switching distance $s_a$		0...0.8 mm	0...0.8 mm	0...0.8 mm
Switching distance marking		■ ■	■ ■	■ ■
PNP, NO	<b>Ordering code</b>	<b>BES00M5</b>	<b>BES00M3</b>	
	Part number	BES 516-3044-G-E4-C-S49-00,3	BES 516-3044-G-E4-C-PU-02	
PNP, NC	<b>Ordering code</b>		<b>BES00M7</b>	
	Part number		BES 516-3045-G-E4-C-PU-02	
NPN, NO	<b>Ordering code</b>			<b>BES00M9</b>
	Part number			BES 516-3046-G-E4-L-PU-02
Supply voltage $U_s$		10...30 V DC	10...30 V DC	10...30 V DC
Voltage drop $U_d$ at $I_e$ max.		2.5 V	2.5 V	1.5 V
Rated insulation voltage $U_i$		75 V DC	75 V DC	75 V DC
Rated operating current $I_e$		100 mA	100 mA	100 mA
Polarity reversal protected/transposition protected/short-circuit protected		Yes/Yes/Yes	Yes/Yes/Yes	Yes/Yes/No
Ambient temperature $T_a$		-25...+70 °C	-25...+70 °C	0...+70 °C
Switching frequency $f$ max.		2 kHz	2 kHz	5 kHz
Output function indicator		Yellow LED	Yellow LED	Yellow LED
Degree of protection as per IEC 60529		IP 67	IP 67	IP 67
Approvals		CE, cULus	CE, cULus	CE
Special properties		<b>Narrow design</b>	<b>Narrow design</b>	<b>Narrow design</b>
Material	Housing	Stainless steel	Stainless steel	Stainless steel
	Sensing surface	POM	POM	POM
Connection		0.3 m PUR cable with M8 connector, 3-pin	2 m PUR cable, 3×0.1 mm <sup>2</sup>	2 m PUR cable, 3×0.1 mm <sup>2</sup>

Wiring diagrams, see page 958.  
The meaning of switching distance markings can be found on page 962.

**Additional cable lengths and PUR cable jacket material available on request**

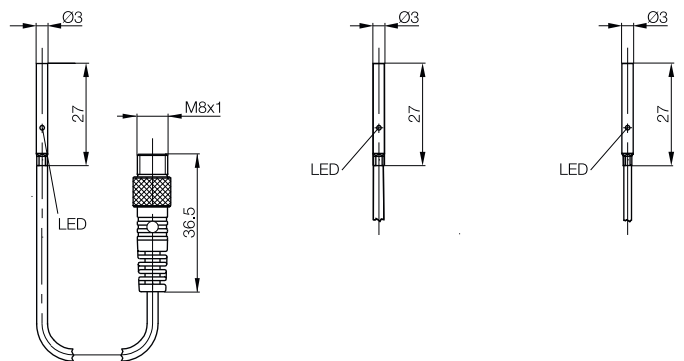

# DC 3-/4-wire Inductive Sensors

## Cylinder design, Ø 3 mm, Ø 4 mm



TRIPLEPROX

		Ø 3 mm	Ø 3 mm	Ø 4 mm
Model				
Installation type (observe instructions in the Basic Information chapter)		Not flush	Not flush	Flush
Rated switching distance $s_n$		<b>3 mm</b>	<b>3 mm</b>	<b>0.8 mm</b>
Assured switching distance $s_a$		0...2.3 mm	0...2.3 mm	0...0.65 mm
Switching distance marking		■ ■	■ ■ ■	■
PNP, NO	<b>Ordering code</b>	<b>BES00MH</b>	<b>BES00ME</b>	<b>BES0122</b>
	Part number	BES 516-3048-G-E4-C-S26-00,3	BES 516-3048-G-E4-C-PU-02	BES G04EC-PSC08B-S26G
PNP, NC	<b>Ordering code</b>		<b>BES00MJ</b>	<b>BES0120</b>
	Part number		BES 516-3049-G-E4-C-PU-02	BES G04EC-POC08B-S26G
NPN, NO	<b>Ordering code</b>			<b>BES011Y</b>
	Part number			BES G04EC-NSC08B-S26G
NPN, NC	<b>Ordering code</b>			<b>BES011W</b>
	Part number			BES G04EC-NOC08B-S26G
Supply voltage $U_s$		21.6...26.4 V DC	21.6...26.4 V DC	10...30 V DC
Voltage drop $U_d$ at $I_e$ max.		2.5 V	2.5 V	3 V
Rated insulation voltage $U_i$		75 V DC	75 V DC	75 V DC
Rated operating current $I_e$		50 mA	50 mA	100 mA
Polarity reversal protected/transposition protected/short-circuit protected		Yes/Yes/Yes	Yes/Yes/Yes	Yes/Yes/Yes
Ambient temperature $T_a$		0...+70 °C	0...+70 °C	-25...+70 °C
Switching frequency $f$ max.		3 kHz	3 kHz	3 kHz
Output function indicator		Yellow LED	Yellow LED	Yellow LED
Degree of protection as per IEC 60529		IP 67	IP 67	IP 67
Approvals		CE, cULus	CE, cULus	CE, cULus
Special properties		<b>Narrow design</b>	<b>Narrow design, large switching distance</b>	<b>Narrow design</b>
Material	Housing	Stainless steel	Stainless steel	Stainless steel
	Sensing surface	PET-C	PET-C	PBT
Connection		0.3 m PUR cable with M5 connector, 4-pin	2 m PUR cable, 3x0.1 mm <sup>2</sup>	M5 connector, 4-pin

Wiring diagrams, see page 958.  
The meaning of switching distance markings can be found on page 962.

**Additional cable lengths and PUR cable jacket material available on request**

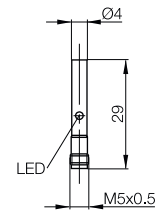
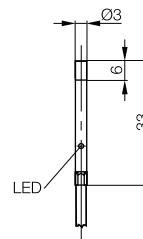
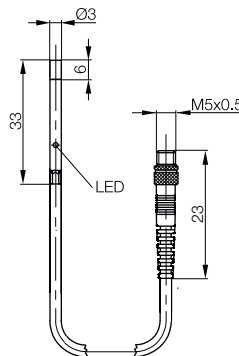



<b>Ø 4 mm</b>	<b>Ø 4 mm</b>	<b>Ø 4 mm</b>	<b>Ø 4 mm</b>	<b>Ø 4 mm</b>
Flush	Flush	Flush	Flush	Flush
<b>0.8 mm</b>	<b>0.8 mm</b>	<b>0.8 mm</b>	<b>0.8 mm</b>	<b>1.5 mm</b>
0...0.65 mm	0...0.65 mm	0...0.65 mm	0...0.65 mm	0...1.2 mm
■	■	■	■	■ ■
<b>BES00J5</b>	<b>BES00J3</b>	<b>BES00J0</b>	<b>BES00HW</b>	<b>BES012F</b>
BES 516-3007-E5-C-S49	BES 516-3007-E4-C-S49-00,3	BES 516-3007-E4-C-S4-00,3	BES 516-3007-E4-C-PU-02	BES G04ED-PSC15B-S26G
<b>BES00K4</b>	<b>BES00K3</b>		<b>BES00K1</b>	<b>BES012A</b>
BES 516-3017-E5-C-S49	BES 516-3017-E4-C-S49-00,3		BES 516-3017-E4-C-PU-02	BES G04ED-POC15B-S26G
			<b>BES00JP</b>	<b>BES0126</b>
			BES 516-3008-E4-C-PU-02	BES G04ED-NSC15B-S26G
<b>BES00KF</b>			<b>BES00KC</b>	<b>BES0123</b>
BES 516-3018-E5-C-S49			BES 516-3018-E4-C-PU-02	BES G04ED-NOC15B-S26G
10...30 V DC	10...30 V DC	10...30 V DC	10...30 V DC	10...30 V DC
3 V	3 V	3 V	3 V	3 V
75 V DC	75 V DC	75 V DC	75 V DC	75 V DC
100 mA	100 mA	100 mA	100 mA	100 mA
Yes/Yes/Yes	Yes/Yes/Yes	Yes/Yes/Yes	Yes/Yes/Yes	Yes/Yes/Yes
-25...+70 °C	-25...+70 °C	-25...+70 °C	-25...+70 °C	-25...+70 °C
3 kHz	3 kHz	3 kHz	3 kHz	3 kHz
Yellow LED	Yellow LED	Yellow LED	Yellow LED	Yellow LED
IP 67	IP 67	IP 67	IP 67	IP 67
CE, cULus	CE, cULus	CE, cULus	CE, cULus	CE, cULus
<b>Narrow design</b>	<b>Narrow design</b>	<b>Narrow design</b>	<b>Narrow design</b>	<b>Narrow design</b>
Stainless steel	Stainless steel	Stainless steel	Stainless steel	Stainless steel
PBT	PBT	PBT	PBT	PBT
M8 connector, 3-pin	0.3 m PUR cable with M8 connector, 3-pin	0.3 m PUR cable with M12 connector, 4-pin	2 m PUR cable, 3x0.14 mm <sup>2</sup>	M5 connector, 4-pin

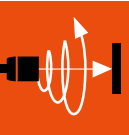

Inductive Sensors  
Global DC 3-wire  
DC 3-/4-wire  
Cylinder Designs  
Block Designs  
DC 2-wire  
AC/DC 2-wire  
AC 2-wire  
Special Properties  
Analog Distance measurement  
Accessories

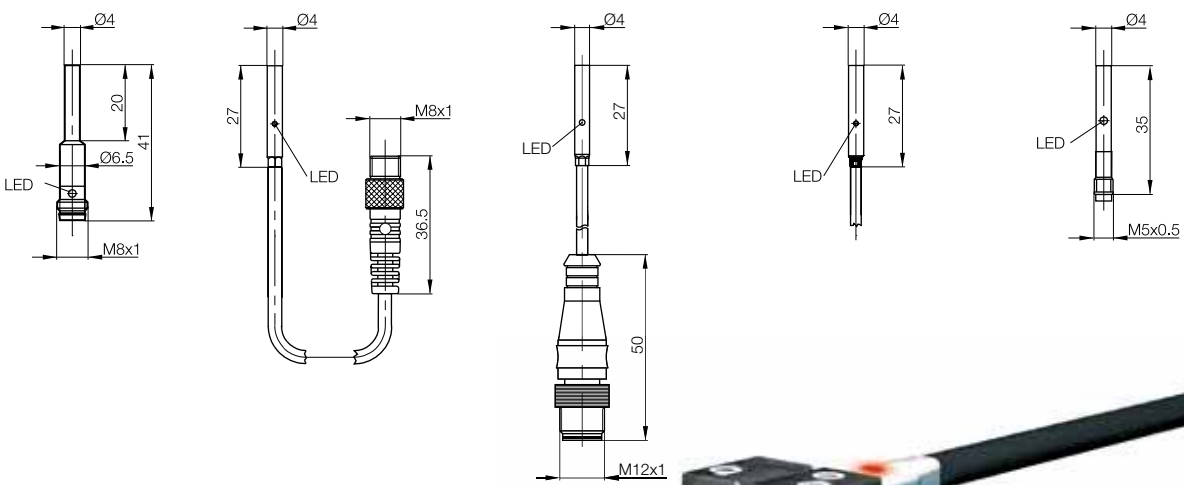

### mini.s

#### Mini design – Maximum power

Inductive sensors Ø 3 mm: Large switching distance with smallest installation space. For even more function reserve and flexibility in application.

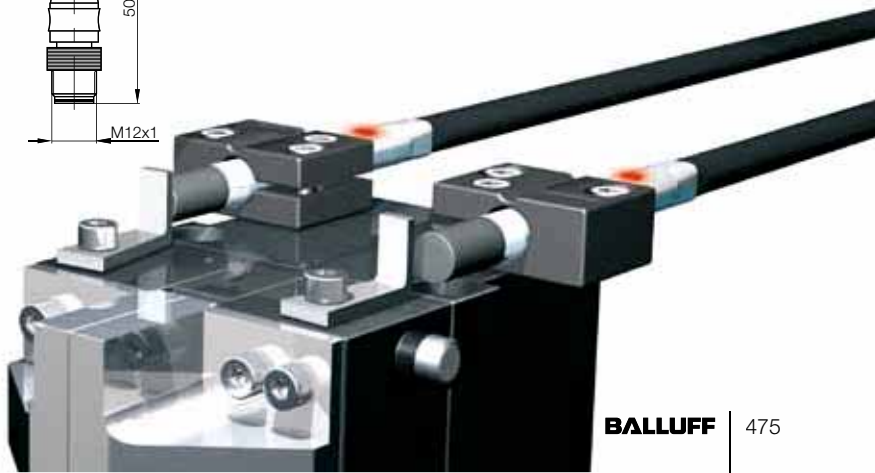

# DC 3-/4-wire Inductive Sensors

## Cylinder designs, Ø 4 mm



Model		<b>Ø 4 mm</b>	<b>Ø 4 mm</b>	<b>Ø 4 mm</b>
Installation type (observe instructions in the Basic Information chapter)		Flush	Flush	Flush
Rated switching distance $s_n$		<b>1.5 mm</b>	<b>1.5 mm</b>	<b>1.5 mm</b>
Assured switching distance $s_a$		0...1.2 mm	0...1.2 mm	0...1.2 mm
Switching distance marking		■ ■	■ ■	■ ■
PNP, NO	<b>Ordering code</b>	<b>BES00JN</b>	<b>BES00J8</b>	<b>BES00JJ</b>
	Part number	BES 516-3007-G-E5-C-S49	BES 516-3007-G-E4-C-S26-00,2	BES 516-3007-G-E4-C-S49-00,3
PNP, NC	<b>Ordering code</b>	<b>BES00KA</b>		<b>BES00K9</b>
	Part number	BES 516-3017-G-E5-C-S49		BES 516-3017-G-E4-C-S49-00,3
NPN, NO	<b>Ordering code</b>	<b>BES00KO</b>		
	Part number	BES 516-3008-G-E5-C-S49		
NPN, NC	<b>Ordering code</b>	<b>BES00KK</b>		
	Part number	BES 516-3018-G-E5-C-S49		
Supply voltage $U_s$		10...30 V DC	10...30 V DC	10...30 V DC
Voltage drop $U_d$ at $I_e$ max.		3 V	3 V	3 V
Rated insulation voltage $U_i$		75 V DC	75 V DC	75 V DC
Rated operating current $I_e$		100 mA	100 mA	100 mA
Polarity reversal protected/transposition protected/short-circuit protected		Yes/Yes/Yes	Yes/Yes/Yes	Yes/Yes/Yes
Ambient temperature $T_a$		-25...+70 °C	-25...+70 °C	-25...+70 °C
Switching frequency $f$ max.		3 kHz	3 kHz	3 kHz
Output function indicator		Yellow LED	Yellow LED	Yellow LED
Degree of protection as per IEC 60529		IP 67	IP 67	IP 67
Approvals		CE, cULus	CE, cULus	CE, cULus
Special properties		<b>Narrow design</b>	<b>Narrow design</b>	<b>Narrow design</b>
Material	Housing	Stainless steel	Stainless steel	Stainless steel
	Sensing surface	PBT	PBT	PBT
Connection		M8 connector, 3-pin	0.2 m PUR cable with M5 connector, 4-pin	0.3 m PUR cable with M8 connector, 3-pin

Wiring diagrams, see page 958.  
The meaning of switching distance markings can be found on page 962.

**Additional cable lengths and PUR cable jacket material available on request**

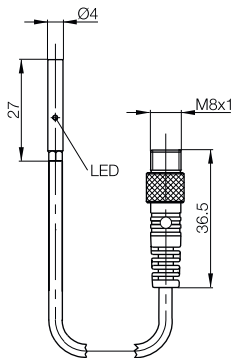
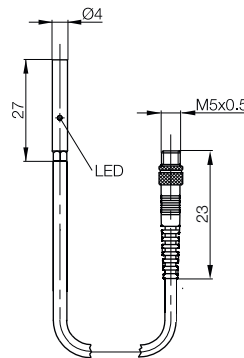
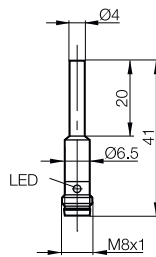

# DC 3-/4-wire Inductive Sensors

## Cylinder designs, Ø 4 mm



Ø 4 mm	Ø 4 mm	Ø 4 mm	Ø 4 mm	Ø 4 mm
Flush	Flush	Flush	Not flush	Not flush
<b>1.5 mm</b>	<b>1.5 mm</b>	<b>1.5 mm</b>	<b>5 mm</b>	<b>5 mm</b>
0...1.2 mm	0...1.2 mm	0...1.2 mm	0...4 mm	0...4 mm
■ ■	■ ■	■ ■	■ ■ ■	■ ■ ■
	<b>BES00JA</b>	<b>BES00J6</b>	<b>BES012K</b>	<b>BES012H</b>
	BES 516-3007-G-E4-C-S4-00,3	BES 516-3007-G-E4-C-PU-02	BES G04ED-PSC50F-S26G	BES G04ED-PSC50F-EP02
		<b>BES00K5</b>	<b>BES012E</b>	<b>BES0127</b>
		BES 516-3017-G-E4-C-PU-02	BES G04ED-POC50F-S26G	BES G04ED-NSC50F-EP02
<b>BES0156</b>		<b>BES00JW</b>	<b>BES0129</b>	
BES 516-3008-G-E4-C-S49-PU-00,3		BES 516-3008-G-E4-C-PU-02	BES G04ED-NSC50F-S26G	
		<b>BES00KH</b>	<b>BES0125</b>	
		BES 516-3018-G-E4-C-PU-02	BES G04ED-NOC50F-S26G	
10...30 V DC	10...30 V DC	10...30 V DC	10...30 V DC	10...30 V DC
3 V	3 V	3 V	2.5 V	2.5 V
75 V DC	75 V DC	75 V DC	75 V DC	75 V DC
100 mA	100 mA	100 mA	100 mA	100 mA
Yes/Yes/Yes	Yes/Yes/Yes	Yes/Yes/Yes	Yes/Yes/Yes	Yes/Yes/Yes
-25...+70 °C	-25...+70 °C	-25...+70 °C	-25...+70 °C	-25...+70 °C
1.8 kHz	3 kHz	3 kHz	3 kHz	3 kHz
Yellow LED	Yellow LED	Yellow LED	Yellow LED	Yellow LED
IP 67	IP 67	IP 67	IP 67	IP 67
CE, cULus	CE, cULus	CE, cULus	CE, cULus	CE, cULus
<b>Narrow design</b>	<b>Narrow design</b>	<b>Narrow design</b>	<b>Narrow design, large switching distance</b>	<b>Narrow design, large switching distance</b>
Stainless steel	Stainless steel	Stainless steel	Stainless steel	Stainless steel
PBT	PBT	PBT	PET-C	PET-C
0.3 m PUR cable with M8 connector, 3-pin	0.3 m PUR cable with M12 connector, 4-pin	2 m PUR cable, 3x0.14 mm <sup>2</sup>	M5 connector, 4-pin	2 m PUR cable, 3x0.14 mm <sup>2</sup>

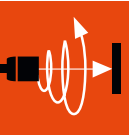

- Inductive Sensors
- Global DC 3-wire
- DC 3-/4-wire
- Cylinder Designs
- Block Designs
- DC 2-wire
- AC/DC 2-wire
- AC 2-wire
- Special Properties
- Analog Distance measurement
- Accessories

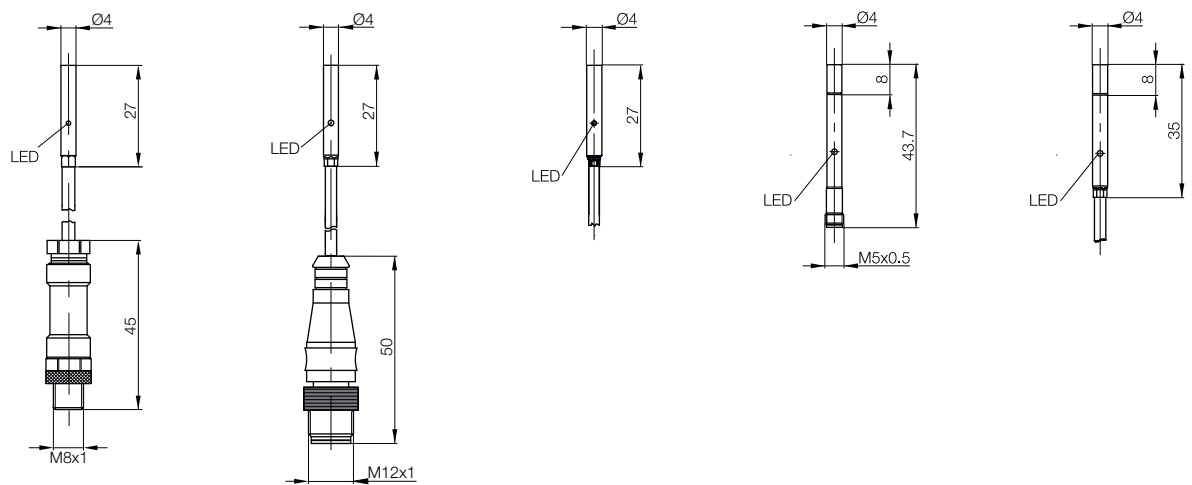

# DC 3-/4-wire Inductive Sensors

## Cylinder design, M5x0.5



Model		<b>M5x0.5</b>	<b>M5x0.5</b>	<b>M5x0.5</b>
Installation type (observe instructions in the Basic Information chapter)		Flush	Flush	Flush
Rated switching distance $s_n$		<b>0.8 mm</b>	<b>0.8 mm</b>	<b>0.8 mm</b>
Assured switching distance $s_a$		0...0.65 mm	0...0.65 mm	0...0.65 mm
Switching distance marking		■	■	■
PNP, NO	<b>Ordering code</b>	<b>BES012Z</b>	<b>BES00H2</b>	<b>BES00H1</b>
	Part number	BES M05EC-PSC08B-S26G	BES 516-3005-E5-C-S49	BES 516-3005-E4-C-S49-00,3
PNP, NC	<b>Ordering code</b>	<b>BES012Y</b>	<b>BES00L1</b>	
	Part number	BES M05EC-POC08B-S26G	BES 516-3022-E5-C-S49	
NPN, NO	<b>Ordering code</b>	<b>BES012W</b>	<b>BES00HL</b>	
	Part number	BES M05EC-NSC08B-S26G	BES 516-3006-E5-C-S49	
NPN, NC	<b>Ordering code</b>	<b>BES012U</b>	<b>BES00L8</b>	
	Part number	BES M05EC-NOC08B-S26G	BES 516-3023-E5-C-S49	
Supply voltage $U_s$		10...30 V DC	10...30 V DC	10...30 V DC
Voltage drop $U_d$ at $I_e$ max.		3 V	3 V	3 V
Rated insulation voltage $U_i$		75 V DC	75 V DC	75 V DC
Rated operating current $I_e$		100 mA	100 mA	100 mA
Polarity reversal protected/transposition protected/short-circuit protected		Yes/Yes/Yes	Yes/Yes/Yes	Yes/Yes/Yes
Ambient temperature $T_a$		-25...+70 °C	-25...+70 °C	-25...+70 °C
Switching frequency $f$ max.		3 kHz	3 kHz	3 kHz
Output function indicator		Yellow LED	Yellow LED	Yellow LED
Degree of protection as per IEC 60529		IP 67	IP 67	IP 67
Approvals		CE, cULus	CE, cULus	CE, cULus
Special properties		<b>Narrow design</b>	<b>Narrow design</b>	<b>Narrow design</b>
Material	Housing	Stainless steel	Stainless steel	Stainless steel
	Sensing surface	PBT	PBT	PBT
Connection		M5 connector, 4-pin	M8 connector, 3-pin	0.3 m PUR cable with M8 connector, 3-pin

Wiring diagrams, see page 958.  
The meaning of switching distance markings can be found on page 962.

**Additional cable lengths and PUR cable jacket material available on request**

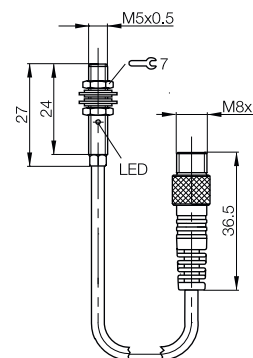
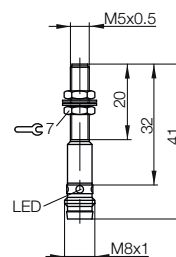
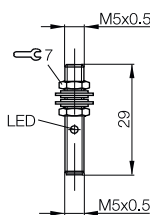



M5x0.5	M5x0.5	M5x0.5	M5x0.5	M5x0.5
Flush	Flush	Flush	Flush	Flush
<b>0.8 mm</b>	<b>0.8 mm</b>	<b>1.5 mm</b>	<b>1.5 mm</b>	<b>1.5 mm</b>
0...0.65 mm	0...0.65 mm	0...1.2 mm	0...1.2 mm	0...1.2 mm
■	■	■ ■	■ ■	■ ■
<b>BES00FW</b>	<b>BES00FT</b>	<b>BES013A</b>	<b>BES00HF</b>	<b>BES00H5</b>
BES 516-3005-E4-C-S4-00,3	BES 516-3005-E4-C-PU-02	BES M05ED-PSC15B-S26G	BES 516-3005-G-E5-C-S49	BES 516-3005-G-E4-C-S26-00,3
	<b>BES00KZ</b>	<b>BES0137</b>		
	BES 516-3022-E4-C-PU-02	BES M05ED-POC15B-S26G		
	<b>BES00HJ</b>	<b>BES0133</b>		
	BES 516-3006-E4-C-PU-02	BES M05ED-NSC15B-S26G		
	<b>BES00L6</b>	<b>BES0130</b>		
	BES 516-3023-E4-C-PU-02	BES M05ED-NOC15B-S26G		
10...30 V DC	10...30 V DC	10...30 V DC	10...30 V DC	10...30 V DC
3 V	3 V	3 V	3 V	3 V
75 V DC	75 V DC	75 V DC	75 V DC	75 V DC
100 mA	100 mA	100 mA	100 mA	100 mA
Yes/Yes/Yes	Yes/Yes/Yes	Yes/Yes/Yes	Yes/Yes/Yes	Yes/Yes/Yes
-25...+70 °C	-25...+70 °C	-25...+70 °C	-25...+70 °C	-25...+70 °C
3 kHz	3 kHz	3 kHz	3 kHz	3 kHz
Yellow LED	Yellow LED	Yellow LED	Yellow LED	Yellow LED
IP 67	IP 67	IP 67	IP 67	IP 67
CE, cULus	CE, cULus	CE, cULus	CE, cULus	CE, cULus
<b>Narrow design</b>	<b>Narrow design</b>	<b>Narrow design</b>	<b>Narrow design</b>	<b>Narrow design</b>
Stainless steel	Stainless steel	Stainless steel	Stainless steel	Stainless steel
PBT	PBT	PBT	PBT	PBT
0.3 m PUR cable with M12 connector, 4-pin	2 m PUR cable, 3x0.14 mm <sup>2</sup>	M5 connector, 4-pin	M8 connector, 3-pin	0.3 m PUR cable with M5 connector, 4-pin

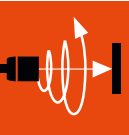

Inductive Sensors  
Global DC 3-wire  
DC 3-/4-wire  
Cylinder Designs  
Block Designs  
DC 2-wire  
AC/DC 2-wire  
AC 2-wire  
Special Properties  
Analog Distance measurement  
Accessories

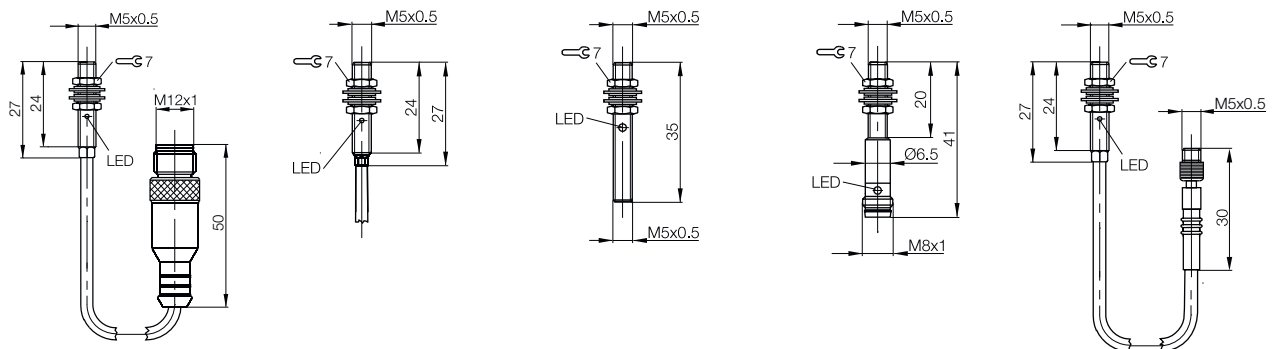



# DC 3-/4-wire Inductive Sensors

## Cylinder design, M5x0.5



Model		<b>M5x0.5</b>	<b>M5x0.5</b>	<b>M5x0.5</b>
Installation type (observe instructions in the Basic Information chapter)		Flush	Flush	Flush
Rated switching distance $s_n$		<b>1.5 mm</b>	<b>1.5 mm</b>	<b>1.5 mm</b>
Assured switching distance $s_a$		0...1.2 mm	0...1.2 mm	0...1.2 mm
Switching distance marking		■ ■	■ ■	■ ■
PNP, NO	<b>Ordering code</b>	<b>BES00HC</b>	<b>BES00H7</b>	<b>BES00H3</b>
	Part number	BES 516-3005-G-E4-C-S49-00,3	BES 516-3005-G-E4-C-S4-00,3	BES 516-3005-G-E4-C-PU-02
PNP, NC	<b>Ordering code</b>	<b>BES00L4</b>		<b>BES00L2</b>
	Part number	BES 516-3022-G-E4-C-S49-00,3		BES 516-3022-G-E4-C-PU-02
NPN, NO	<b>Ordering code</b>			<b>BES00HM</b>
	Part number			BES 516-3006-G-E4-C-PU-02
NPN, NC	<b>Ordering code</b>			
	Part number			
Supply voltage $U_s$		10...30 V DC	10...30 V DC	10...30 V DC
Voltage drop $U_d$ at $I_o$ max.		3 V	3 V	3 V
Rated insulation voltage $U_i$		75 V DC	75 V DC	75 V DC
Rated operating current $I_o$		100 mA	100 mA	100 mA
Polarity reversal protected/transposition protected/short-circuit protected		Yes/Yes/Yes	Yes/Yes/Yes	Yes/Yes/Yes
Ambient temperature $T_a$		-25...+70 °C	-25...+70 °C	-25...+70 °C
Switching frequency $f$ max.		3 kHz	3 kHz	3 kHz
Output function indicator		Yellow LED	Yellow LED	Yellow LED
Degree of protection as per IEC 60529		IP 67	IP 67	IP 67
Approvals		CE, cULus	CE, cULus	CE, cULus
Special properties		<b>Narrow design</b>	<b>Narrow design</b>	<b>Narrow design</b>
Material	Housing	Stainless steel	Stainless steel	Stainless steel
	Sensing surface	PBT	PBT	PBT
Connection		0.3 m PUR cable with M8 connector, 3-pin	0.3 m PUR cable with M12 connector, 4-pin	2 m PUR cable, 3x0.14 mm <sup>2</sup>

Wiring diagrams, see page 958.  
The meaning of switching distance markings can be found on page 962.

**Additional cable lengths and PUR cable jacket material available on request**

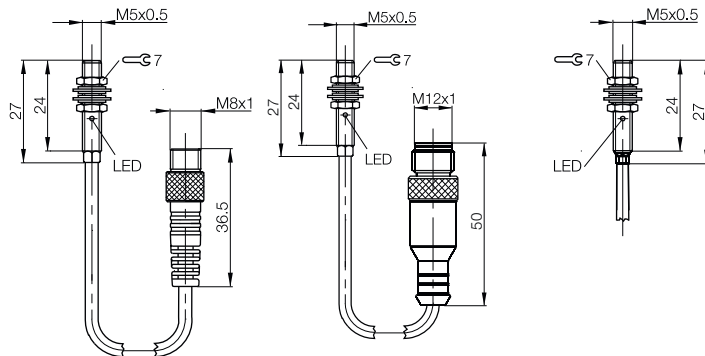

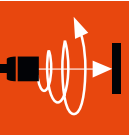

- Inductive Sensors
- Global DC 3-wire
- DC 3-/4-wire
- Cylinder Designs
- Block Designs
- DC 2-wire
- AC/DC 2-wire
- AC 2-wire
- Special Properties
- Analog Distance measurement
- Accessories



	<b>TRIPLEPROX</b>	<b>TRIPLEPROX</b>	<b>TRIPLEPROX</b>	
	<b>M5x0.5</b>	<b>M5x0.5</b>	<b>M5x0.5</b>	
	Not flush	Not flush	Not flush	
	<b>5 mm</b>	<b>5 mm</b>	<b>5 mm</b>	
	0...4 mm	0...4 mm	0...4 mm	
	■■■	■■■	■■■	
	<b>BES013H</b>	<b>BES013C</b>	<b>BES013E</b>	
	BES M05ED-PSC50F-S26G	BES M05ED-PSC50F-EP00,3-GS04	BES M05ED-PSC50F-EP02	
	<b>BES0139</b>			
	BES M05ED-POC50F-S26G			
	<b>BES0136</b>		<b>BES0134</b>	
	BES M05ED-NSC50F-S26G		BES M05ED-NSC50F-EP02	
	<b>BES0132</b>			
	BES M05ED-NOC50F-S26G			
	10...30 V DC	10...30 V DC	10...30 V DC	
	2.5 V	2.5 V	2.5 V	
	75 V DC	75 V DC	75 V DC	
	100 mA	100 mA	100 mA	
	Yes/Yes/Yes	No/Yes/Yes	Yes/Yes/Yes	
	-25...+70 °C	-25...+70 °C	-25...+70 °C	
	3 kHz	3 kHz	3 kHz	
	Yellow LED	Yellow LED	Yellow LED	
	IP 67	IP 67	IP 67	
	CE, cULus	CE, cULus	CE, cULus	
	<b>Narrow design, large switching distance</b>	<b>Narrow design, large switching distance</b>	<b>Narrow design, large switching distance</b>	
	Stainless steel	Stainless steel	Stainless steel	
	PET-C	PET-C	PET-C	
	M5 connector, 4-pin	0.3 m PUR cable with M12 connector, 4-pin	2 m PUR cable, 3x0.14 mm <sup>2</sup>	

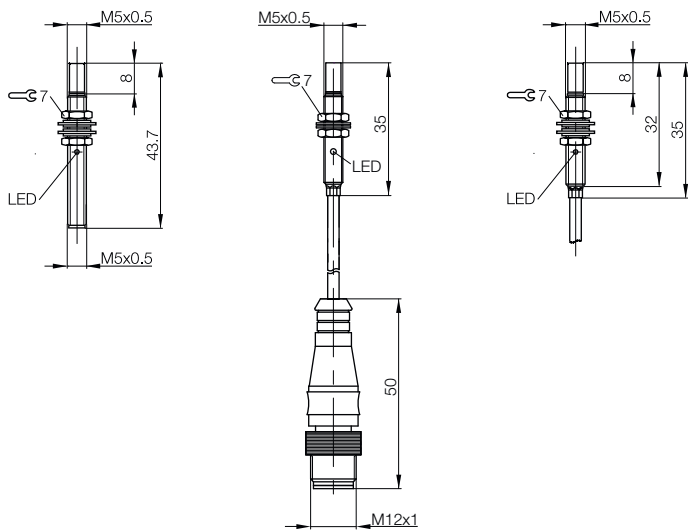

# DC 3-/4-wire Inductive Sensors

## Cylinder design, Ø 6.5 mm



**SUPERSHORTIES**



Model		Ø 6.5 mm	Ø 6.5 mm	Ø 6.5 mm	
Installation type (observe instructions in the Basic Information chapter)		Flush	Flush	Flush	
Rated switching distance $s_n$		<b>1.5 mm</b>	<b>1.5 mm</b>	<b>1.5 mm</b>	
Assured switching distance $s_a$		0...1.2 mm	0...1.2 mm	0...1.2 mm	
Switching distance marking		■	■	■	
PNP, NO	<b>Ordering code</b>	<b>BES025N</b>	<b>BES00ZC</b>	<b>BES01KJ</b>	
	Part number	BES G06EA-PSD15B-S49G	BES 516-371-E5-C-S49	BES 516-371-S49-C	
PNP, NC	<b>Ordering code</b>	<b>BES025J</b>			
	Part number	BES G06EA-POD15B-S49G			
NPN, NO	<b>Ordering code</b>	<b>BES025F</b>			
	Part number	BES G06EA-NSD15B-S49G			
NPN, NC	<b>Ordering code</b>	<b>BES025A</b>			
	Part number	BES G06EA-NOD15B-S49G			
Supply voltage $U_s$		10...30 V DC	10...30 V DC	10...30 V DC	
Voltage drop $U_d$ at $I_o$ max.		2.5 V	2.5 V	2.5 V	
Rated insulation voltage $U_i$ (protection class)		75 V DC	75 V DC	75 V DC	
Rated operating current $I_o$		150 mA	200 mA	200 mA	
Polarity reversal protected/transposition protected/short-circuit protected		Yes/Yes/Yes	Yes/Yes/Yes	Yes/Yes/Yes	
Ambient temperature $T_a$		-25...+70 °C	-25...+70 °C	-25...+70 °C	
Switching frequency $f$ max.		3 kHz	3 kHz	3 kHz	
Output function indicator		No	Yellow LED	Yellow LED	
Degree of protection as per IEC 60529		IP 67	IP 67	IP 67	
Approvals		CE, cULus	CE, cULus	CE, cULus	
Special properties		<b>Short design</b>			
Material	Housing	Stainless steel	Stainless steel	Stainless steel	
	Sensing surface	PBT	PBT	PBT	
Connection		M8 connector, 3-pin	M8 connector, 3-pin	M8 connector, 3-pin	

Wiring diagrams, see page 958.  
The meaning of switching distance markings can be found on page 962.

**Additional cable lengths and PUR cable jacket material available on request**

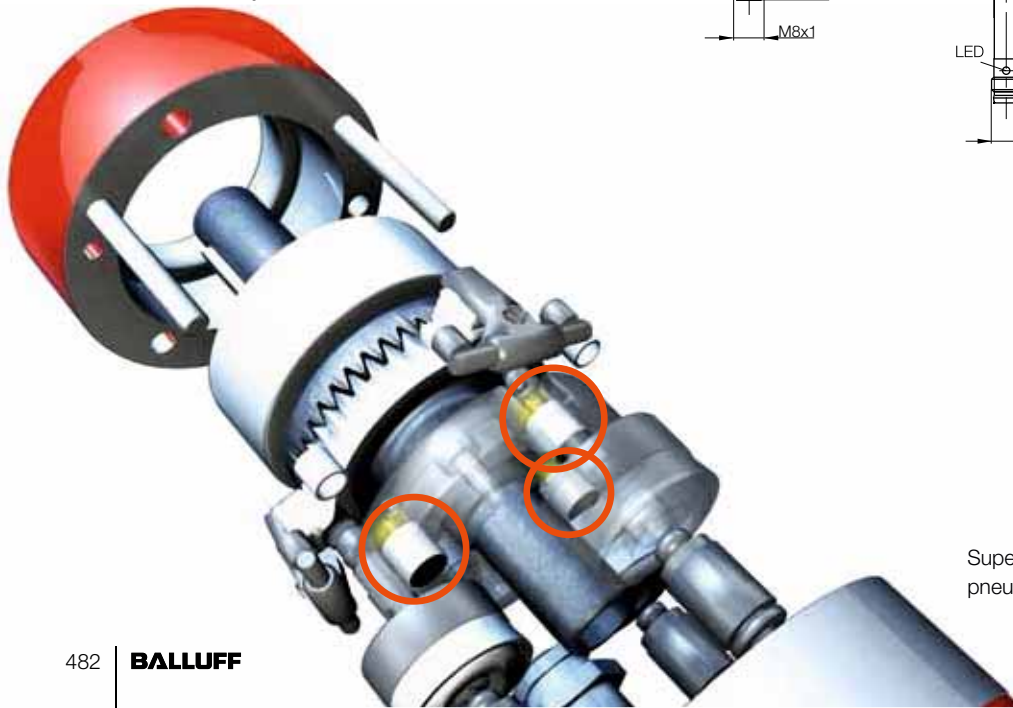
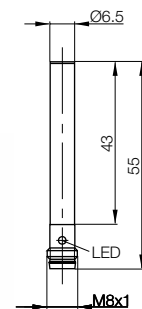
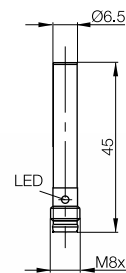
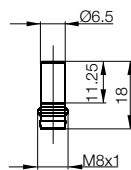

SuperShorties monitor the function of a pneumatic stepping motor.

# DC 3-/4-wire Inductive Sensors

## Cylinder design, Ø 6.5 mm



**SUPER**SHORTIES



**SUPER**SHORTIES



**SUPER**SHORTIES

Ø 6.5 mm	Ø 6.5 mm	Ø 6.5 mm	Ø 6.5 mm	Ø 6.5 mm
Flush	Flush	Flush	Flush	Flush
<b>1.5 mm</b>	<b>1.5 mm</b>	<b>1.5 mm</b>	<b>1.5 mm</b>	<b>1.5 mm</b>
0...1.2 mm	0...1.2 mm	0...1.2 mm	0...1.2 mm	0...1.2 mm
■	■	■	■	■
<b>BES0253</b>	<b>BES0254</b>	<b>BES00ZA</b>	<b>BES00Z8</b>	<b>BES0256</b>
BES G06E60-PSC15B-EP00,3-GS26	BES G06E60-PSC15B-EP00,3-GS49	BES 516-371-E4-C-S49-00,3	BES 516-371-E4-C-S4-00,3	BES G06E60-PSC15B-EP02
				<b>BES0251</b>
				BES G06E60-POC15B-EP02
	<b>BES024Y</b>			<b>BES024Z</b>
	BES G06E60-NSC15B-EP00,3-GS49			BES G06E60-NSC15B-EP02
				<b>BES024W</b>
				BES G06E60-NOC15B-EP02
10...30 V DC	10...30 V DC	10...30 V DC	10...30 V DC	10...30 V DC
2.5 V	2.5 V	2.5 V	2.5 V	2.5 V
75 V DC	75 V DC	250 V AC (□)	250 V AC (□)	75 V DC
150 mA	150 mA	200 mA	200 mA	150 mA
Yes/Yes/Yes	Yes/Yes/Yes	Yes/Yes/Yes	Yes/Yes/Yes	Yes/Yes/Yes
-25...+70 °C	-25...+70 °C	-25...+70 °C	-25...+70 °C	-25...+70 °C
3 kHz	3 kHz	3 kHz	3 kHz	3 kHz
Yellow LED	Yellow LED	Yellow LED	Yellow LED	Yellow LED
IP 67	IP 67	IP 68 per BWN Pr. 20	IP 68 per BWN Pr. 20	IP 67
CE, cULus	CE, cULus	CE, cULus	CE, cULus	CE, cULus
<b>Short design</b>	<b>Short design</b>			<b>Short design</b>
Stainless steel	Stainless steel	Stainless steel	Stainless steel	Stainless steel
PBT	PBT	PBT	PBT	PBT
0.3 m PUR cable with M5 connector, 4-pin	0.3 m PUR cable with M8 connector, 3-pin	0.3 m PUR cable with M8 connector, 3-pin	0.3 m PUR cable with M12 connector, 4-pin	2 m PUR cable, 3x0.073 mm <sup>2</sup>

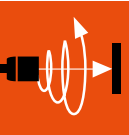

- Inductive Sensors
- Global DC 3-wire
- DC 3-/4-wire
- Cylinder Designs
- Block Designs
- DC 2-wire
- AC/DC 2-wire
- AC 2-wire
- Special Properties
- Analog Distance measurement
- Accessories

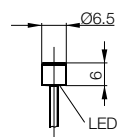
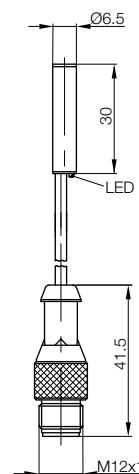
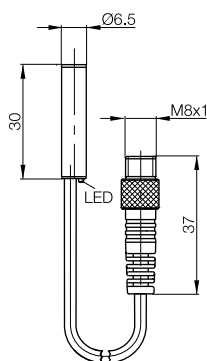
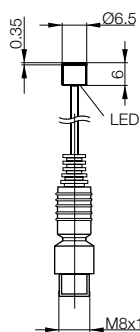
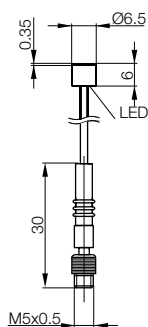

# DC 3-/4-wire Inductive Sensors

## Cylinder design, Ø 6.5 mm



**SUPERSHORTIES**



**SUPERSHORTIES**



**SUPERSHORTIES**

Model		Ø 6.5 mm	Ø 6.5 mm	Ø 6.5 mm
Installation type (observe instructions in the Basic Information chapter)		Flush	Flush	Flush
Rated switching distance $s_n$		<b>1.5 mm</b>	<b>1.5 mm</b>	<b>1.5 mm</b>
Assured switching distance $s_a$		0...1.2 mm	0...1.2 mm	0...1.2 mm
Switching distance marking		■	■	■
PNP, NO	<b>Ordering code</b>	<b>BES025M</b>	<b>BES026F</b>	<b>BES0269</b>
	Part number	BES G06EA-PSC15B-EP02	BES K06K60-PSC15B-EP02	BES K06K40-PSC15B-FP02
PNP, NC	<b>Ordering code</b>	<b>BES025H</b>	<b>BES026E</b>	<b>BES0262</b>
	Part number	BES G06EA-POC15B-EP02	BES K06K60-POC15B-EP02	BES K06K40-POC15B-FP02
NPN, NO	<b>Ordering code</b>	<b>BES025E</b>	<b>BES026C</b>	<b>BES0261</b>
	Part number	BES G06EA-NSC15B-EP02	BES K06K60-NSC15B-EP02	BES K06K40-NSC15B-FP02
NPN, NC	<b>Ordering code</b>	<b>BES0259</b>	<b>BES026A</b>	<b>BES0260</b>
	Part number	BES G06EA-NOC15B-EP02	BES K06K60-NOC15B-EP02	BES K06K40-NOC15B-FP02
Supply voltage $U_s$		10...30 V DC	10...30 V DC	10...30 V DC
Voltage drop $U_d$ at $I_o$ max.		2.5 V	2.5 V	2.5 V
Rated insulation voltage $U_i$ (protection class)		75 V DC	75 V DC	75 V DC
Rated operating current $I_o$		150 mA	150 mA	150 mA
Polarity reversal protected/transposition protected/short-circuit protected		Yes/Yes/Yes	Yes/Yes/Yes	Yes/Yes/Yes
Ambient temperature $T_a$		-25...+70 °C	-25...+70 °C	-25...+70 °C
Switching frequency $f$ max.		3 kHz	3 kHz	3 kHz
Output function indicator		Yellow LED	Yellow LED	Yellow LED
Degree of protection as per IEC 60529		IP 67	IP 65	IP 65
Approvals		CE, cULus	CE, cULus	CE, cULus
Special properties		<b>Short design</b>	<b>Short design</b>	<b>Short design</b>
Material	Housing	Stainless steel	PBT	PBT
	Sensing surface	PBT	PBT	PBT
Connection		2 m PUR cable, 3x0.073 mm <sup>2</sup>	2 m PUR cable, 3x0.073 mm <sup>2</sup>	2 m PUR cable, 3x0.073 mm <sup>2</sup>

Wiring diagrams, see page 958.  
The meaning of switching distance markings can be found on page 962.

**Additional cable lengths and PUR cable jacket material available on request**

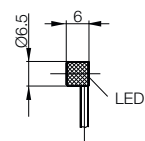
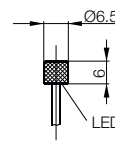
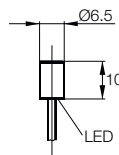

### Features

- Simple installation with glue-in sensor
- Flexible use with optional radial cable outlet

### Recommendation for gluing in the sensor Ø 6.5 mm smooth

Prepare and clean drill hole and sensor according to the specifications of the glue used. Coat hole and sensor with adhesive and position sensor in hole. Allow to cure. For additional instructions, see the data sheet.

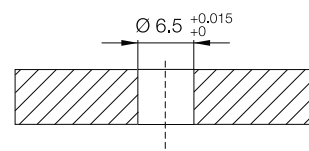

# DC 3-/4-wire Inductive Sensors

## Cylinder design, Ø 6.5 mm

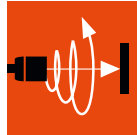

Inductive Sensors  
Global DC 3-wire  
DC 3-/4-wire  
Cylinder Designs  
Block Designs  
DC 2-wire  
AC/DC 2-wire  
AC 2-wire  
Special Properties  
Analog Distance measurement  
Accessories



**SUPERSHORTIES**

Ø 6.5 mm	Ø 6.5 mm	Ø 6.5 mm	Ø 6.5 mm	Ø 6.5 mm
Flush	Flush	Flush	Flush	Flush
<b>1.5 mm</b>	<b>1.5 mm</b>	<b>1.5 mm</b>	<b>2 mm</b>	<b>2 mm</b>
0...1.2 mm	0...1.2 mm	0...1.2 mm	0...1.6 mm	0...1.6 mm
■	■	■	■ ■	■ ■
<b>BES00Z2</b>	<b>BES00Z5</b>	<b>BES01K7</b>		<b>BES037K</b>
BES 516-371-E4-C-02	BES 516-371-E4-C-PU-02	BES 516-371-EO-C-02		BES 516-371-SA15-C-S49
			<b>BES025K</b>	
			BES G06EA-POD20B-S49G	
<b>BES00ZW</b>	<b>BES0100</b>	<b>BES01L1</b>		
BES 516-372-E4-C-02	BES 516-372-E4-C-PU-02	BES 516-372-EO-C-02		
			<b>BES025C</b>	
			BES G06EA-NOD20B-S49G	
10...30 V DC	10...30 V DC	10...30 V DC	10...30 V DC	10...30 V DC
2.5 V	2.5 V	2.5 V	2.5 V	2.5 V
250 V AC (□)	250 V AC (□)	250 V AC (□)	75 V DC	75 V DC
200 mA	200 mA	200 mA	150 mA	200 mA
Yes/Yes/Yes	Yes/Yes/Yes	Yes/Yes/Yes	Yes/Yes/Yes	Yes/Yes/Yes
-25...+70 °C	-25...+70 °C	-25...+70 °C	-25...+70 °C	-25...+70 °C
3 kHz	3 kHz	3 kHz	3 kHz	1.5 kHz
Yellow LED	Yellow LED	Yellow LED	No	Yellow LED
IP 68 per BWN Pr. 20	IP 68 per BWN Pr. 20	IP 68 per BWN Pr. 20	IP 67	IP 67
CE, cULus	CE, cULus	CE, cULus	CE, cULus	CE, cULus
Stainless steel	Stainless steel	Stainless steel	<b>Short design</b> Stainless steel	Stainless steel
PBT	PBT	PBT	PBT	PBT
2 m PVC cable, 3x0.14 mm <sup>2</sup>	2 m PUR cable, 3x0.14 mm <sup>2</sup>	2 m PVC cable, 3x0.14 mm <sup>2</sup>	M8 connector, 3-pin	M8 connector, 3-pin

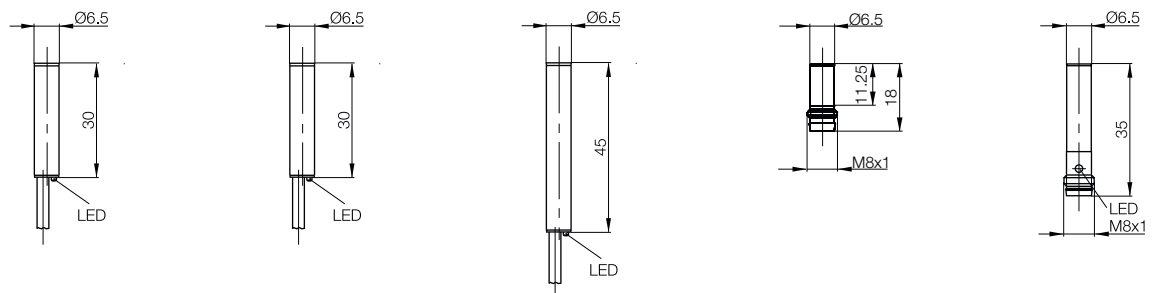

SuperShorties in electronics production: Automatic board assembler

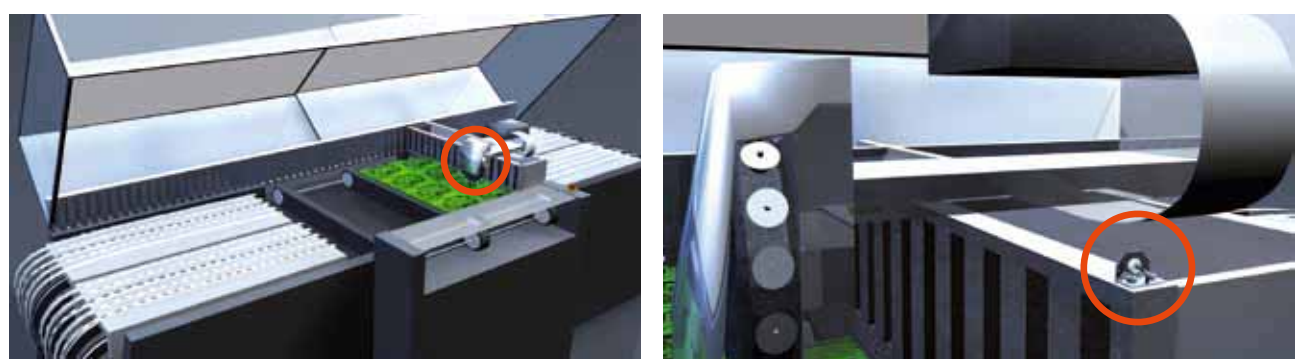

# DC 3-/4-wire Inductive Sensors

## Cylinder design, Ø 6.5 mm



**SUPERSHORTIES**

Model		Ø 6.5 mm	Ø 6.5 mm	Ø 6.5 mm
Installation type (observe instructions in the Basic Information chapter)		Flush	Flush	Flush
Rated switching distance $s_n$		<b>2 mm</b>	<b>2 mm</b>	<b>2 mm</b>
Assured switching distance $s_a$		0...1.6 mm	0...1.6 mm	0...1.6 mm
Switching distance marking		■ ■	■ ■	■ ■
PNP, NO	<b>Ordering code</b>	<b>BES00ZU</b>	<b>BES01KH</b>	<b>BES0257</b>
	Part number	BES 516-371-G-E5-C-S49	BES 516-371-G-S49-C	BES G06E60-PSC20B-EP00,3-GS49
PNP, NC	<b>Ordering code</b>	<b>BES00KY</b>		
	Part number	BES 516-3021-G-E5-C-S49		
NPN, NO	<b>Ordering code</b>	<b>BES0107</b>	<b>BES03RU</b>	
	Part number	BES 516-372-G-E5-C-S49	BES G06EH-NSC20B-S49G	
NPN, NC	<b>Ordering code</b>		<b>BES03RW</b>	
	Part number		BES G06EH-NOC20B-S49G	
Supply voltage $U_s$		10...30 V DC	10...30 V DC	10...30 V DC
Voltage drop $U_d$ at $I_o$ max.		2.5 V	2.5 V	2.5 V
Rated insulation voltage $U_i$ (protection class)		75 V DC	75 V DC	75 V DC
Rated operating current $I_o$		200 mA	200 mA	150 mA
Polarity reversal protected/transposition protected/short-circuit protected		Yes/Yes/Yes	Yes/Yes/Yes	Yes/Yes/Yes
Ambient temperature $T_a$		-25...+70 °C	-25...+70 °C	-25...+70 °C
Switching frequency $f$ max.		1.5 kHz	1.5 kHz	3 kHz
Output function indicator		Yellow LED	Yellow LED	Yellow LED
Degree of protection as per IEC 60529		IP 67	IP 67	IP 67
Approvals		CE, cULus	CE, cULus	CE, cULus
Special properties				<b>Short design</b>
Material	Housing	Stainless steel	Stainless steel	Stainless steel
	Sensing surface	PBT	PBT	PBT
Connection		M8 connector, 3-pin	M8 connector, 3-pin	0.3 m PUR cable with M8 connector, 3-pin

Wiring diagrams, see page 958.  
The meaning of switching distance markings can be found on page 962.

**Additional cable lengths and PUR cable jacket material available on request**

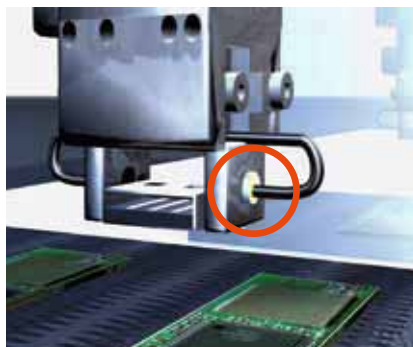
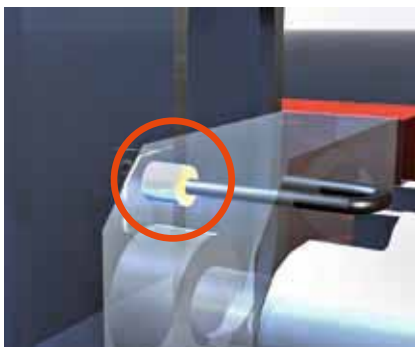
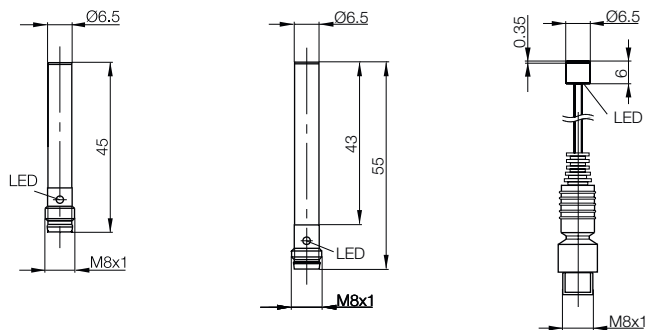





Ø 6.5 mm	Ø 6.5 mm	Ø 6.5 mm	Ø 6.5 mm	Ø 6.5 mm
Flush	Flush	Flush	Flush	Flush
<b>2 mm</b>	<b>2 mm</b>	<b>2 mm</b>	<b>2 mm</b>	<b>2 mm</b>
0...1.6 mm	0...1.6 mm	0...1.6 mm	0...1.6 mm	0...1.6 mm
■ ■	■ ■	■ ■	■ ■	■ ■
<b>BES00ZR</b>	<b>BES00ZN</b>	<b>BES0258</b>	<b>BES01KW</b>	<b>BES00ZF</b>
BES 516-371-G-E4-C-S49-00,3	BES 516-371-G-E4-C-S4-00,2	BES G06E60-PSC20B-EP02	BES 516-371-SA13-PU-02	BES 516-371-G-E4-C-02
<b>BES03F8</b>	<b>BES00KU</b>			<b>BES00KP</b>
BES 516-3021-G-E4-C-S49-00,3	BES 516-3021-G-E4-C-S4-00,2			BES 516-3021-G-E4-C-02
<b>BES0106</b>		<b>BES0250</b>		<b>BES0102</b>
BES 516-372-G-E4-C-S49-00,3		BES G06E60-NSC20B-EP02		BES 516-372-G-E4-C-02
10...30 V DC	10...30 V DC	10...30 V DC	10...30 V DC	10...30 V DC
2.5 V	2.5 V	2.5 V	2.5 V	2.5 V
250 V AC (□)	250 V AC (□)	75 V DC	75 V DC	250 V AC (□)
200 mA	200 mA	150 mA	200 mA	200 mA
Yes/Yes/Yes	Yes/Yes/Yes	Yes/Yes/Yes	Yes/Yes/Yes	Yes/Yes/Yes
-25...+70 °C	-25...+70 °C	-25...+70 °C	-25...+70 °C	-25...+70 °C
1.5 kHz	1.5 kHz	3 kHz	2 kHz	1.5 kHz
Yellow LED	Yellow LED	Yellow LED	No	Yellow LED
IP 68 per BWN Pr. 20	IP 68 per BWN Pr. 20	IP 67	IP 65	IP 68 per BWN Pr. 20
CE, cULus	CE, cULus	CE, cULus	CE	CE, cULus
		<b>Short design</b>		
Stainless steel	Stainless steel	Stainless steel	Stainless steel	Stainless steel
PBT	PBT	PBT	PBT	PBT
0.3 m PUR cable with M8 connector, 3-pin	0.2 m PUR cable with M12 connector, 4-pin	2 m PUR cable, 3x0.073 mm <sup>2</sup>	2 m PUR cable, 3x0.14 mm <sup>2</sup>	2 m PVC cable, 3x0.14 mm <sup>2</sup>

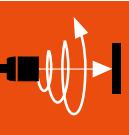

- Inductive Sensors
- Global DC 3-wire
- DC 3-/4-wire
- Cylinder Designs
- Block Designs
- DC 2-wire
- AC/DC 2-wire
- AC 2-wire
- Special Properties
- Analog Distance measurement
- Accessories

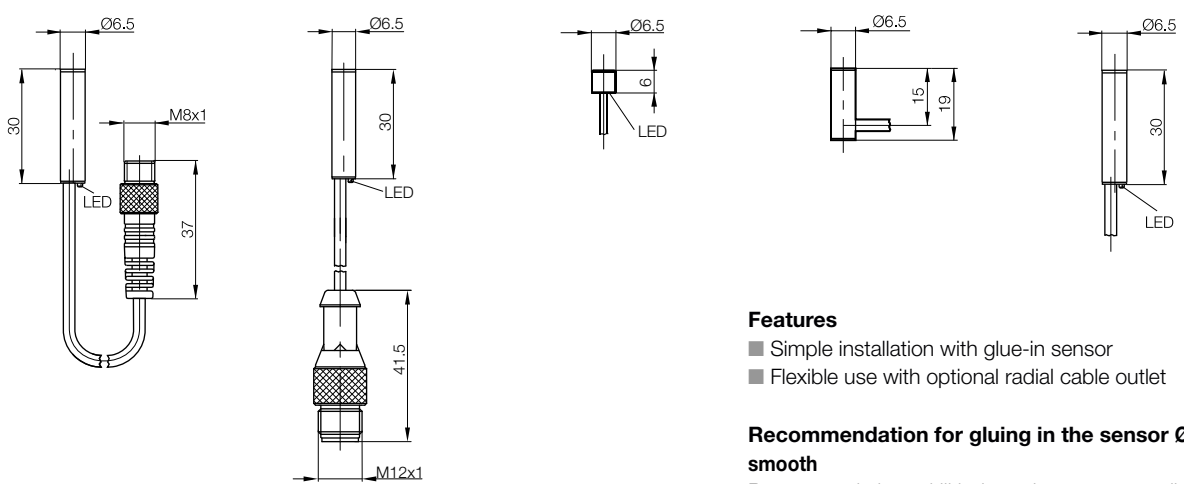

**Features**

- Simple installation with glue-in sensor
- Flexible use with optional radial cable outlet

**Recommendation for gluing in the sensor Ø 6.5 mm smooth**

Prepare and clean drill hole and sensor according to the specifications of the glue used. Coat hole and sensor with adhesive and position sensor in hole. Allow to cure. For additional instructions, see the data sheet.

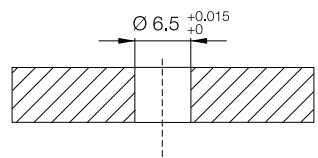

# DC 3-/4-wire Inductive Sensors

## Cylinder design, Ø 6.5 mm



TRIPLEPROX



TRIPLEPROX



HYPERPROX

Model		Ø 6.5 mm	Ø 6.5 mm	Ø 6.5 mm
Installation type (observe instructions in the Basic Information chapter)		Quasi-flush	Quasi-flush	Quasi-flush
Rated switching distance $s_n$		3 mm	3 mm	4 mm
Assured switching distance $s_a$		0...2.4 mm	0...2.4 mm	0...2.9 mm
Switching distance marking		■■■	■■■	■■■■
PNP, NO	Ordering code	BES02UY	BES02UR	BES01NT
	Part number	BES G06MI-PSC30B-S49G	BES G06MH1-PSC30B-S04G	BES G06MI-PSC40B-S49G
PNP, NC	Ordering code	BES02UW		
	Part number	BES G06MI-POC30B-S49G		
NPN, NO	Ordering code	BES02UU	BES02UP	BES01NR
	Part number	BES G06MI-NSC30B-S49G	BES G06MH1-NSC30B-S04G	BES G06MI-NSC40B-S49G
NPN, NC	Ordering code	BES02UT		
	Part number	BES G06MI-NOC30B-S49G		
Supply voltage $U_s$		10...30 V DC	10...30 V DC	10...30 V DC
Voltage drop $U_d$ at $I_e$ max.		2 V	2 V	2.8 V
Rated insulation voltage $U_i$ (protection class)		75 V DC	75 V DC	75 V DC
Rated operating current $I_e$		200 mA	200 mA	200 mA
Polarity reversal protected/transposition protected/short-circuit protected		Yes/Yes/Yes	Yes/Yes/Yes	Yes/Yes/Yes
Ambient temperature $T_a$		-25...+70 °C	-25...+70 °C	0...+60 °C
Switching frequency $f$ max.		1 kHz	1 kHz	700 Hz
Output function indicator		Yellow LED	Yellow LED	Yellow LED
Degree of protection as per IEC 60529		IP 67	IP 67	IP 65
Approvals		CE	CE	CE, cULus
Special properties		<b>Large switching distance</b>	<b>Large switching distance</b>	<b>Large switching distance</b>
Material	Housing	Brass-coated	Brass-coated	Brass-coated
	Sensing surface	PBT	PBT	PBT
Connection		M8 connector, 3-pin	M12 connector, 4-pin	M8 connector, 3-pin

Wiring diagrams, see page 958.  
The meaning of switching distance markings can be found on page 962.

**Additional cable lengths and PUR cable jacket material available on request**

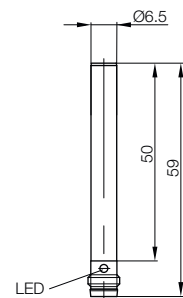
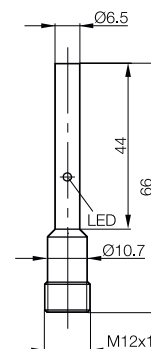
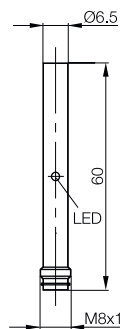



Ø 6.5 mm	Ø 6.5 mm			
Not flush	Not flush			
2.5 mm	4 mm			
0...2 mm	0...3.2 mm			
■	■ ■			
<b>BES00TZ</b>	<b>BES01NP</b>			
BES 516-349-E4-C-02	BES G06EF-PSC40F-S49G			
<b>BES00U6</b>				
BES 516-350-E4-C-02				
10...30 V DC	10...30 V DC			
2.5 V	2.5 V			
250 V AC (□)	75 V DC			
200 mA	200 mA			
Yes/Yes/Yes	Yes/Yes/Yes			
-25...+70 °C	-25...+70 °C			
2 kHz	1.5 kHz			
Yellow LED	Yellow LED			
IP 68 per BWN Pr. 20	IP 67			
CE, cULus	CE, cULus			
Stainless steel	Stainless steel			
PBT	PBT			
2 m PVC cable, 3x0.14 mm <sup>2</sup>	M8 connector, 3-pin			

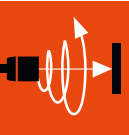

Inductive Sensors  
Global DC 3-wire  
DC 3-/4-wire  
Cylinder Designs  
Block Designs  
DC 2-wire  
AC/DC 2-wire  
AC 2-wire  
Special Properties  
Analog Distance measurement  
Accessories

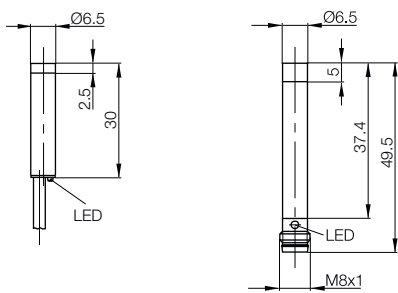

# DC 3-/4-wire Inductive Sensors

## Cylinder designs, Ø 8 mm



Model		<b>Ø 8 mm</b>	<b>Ø 8 mm</b>	<b>Ø 8 mm</b>
Installation type (observe instructions in the Basic Information chapter)		Flush	Flush	Flush
Rated switching distance $s_n$		<b>1.5 mm</b>	<b>2 mm</b>	<b>2 mm</b>
Assured switching distance $s_a$		0...1.2 mm	0...1.6 mm	0...1.6 mm
Switching distance marking		■	■■	■■
PNP, NO	<b>Ordering code</b>	<b>BES01NY</b>	<b>BES0388</b>	<b>BES012N</b>
	Part number	BES G08EG-PSC15B-BV02	BES G08EC-PSC20B-EP01-GS04-516	BES G08EE-PSC20B-BV02
PNP, NC	<b>Ordering code</b>			
	Part number			
NPN, NO	<b>Ordering code</b>			
	Part number			
NPN, NC	<b>Ordering code</b>			
	Part number			
Supply voltage $U_s$		10...30 V DC	10...30 V DC	10...30 V DC
Voltage drop $U_d$ at $I_o$ max.		2.5 V	2.5 V	2.5 V
Rated insulation voltage $U_i$ (protection class)		250 V AC (□)	75 V DC	250 V AC (□)
Rated operating current $I_o$		200 mA	200 mA	200 mA
Polarity reversal protected/transposition protected/short-circuit protected		Yes/Yes/Yes	Yes/Yes/Yes	Yes/Yes/Yes
Ambient temperature $T_a$		-25...+70 °C	-25...+70 °C	-25...+70 °C
Switching frequency $f$ max.		3 kHz	2 kHz	1.5 kHz
Output function indicator		Yellow LED	Yellow LED	Yellow LED
Degree of protection as per IEC 60529		IP 68 per BWN Pr. 20	IP 67	IP 68 per BWN Pr. 20
Approvals		CE, cULus	CE	CE, cULus
Special properties				
Material	Housing	Stainless steel	Stainless steel	Stainless steel
	Sensing surface	PBT	Ceramic	PBT
Connection		2 m PVC cable, 3x0.14 mm <sup>2</sup>	1 m PUR cable with M12 connector, 4-pin	2 m PVC cable, 3x0.14 mm <sup>2</sup>

Wiring diagrams, see page 958.  
The meaning of switching distance markings can be found on page 962.

**Additional cable lengths and PUR cable jacket material available on request**

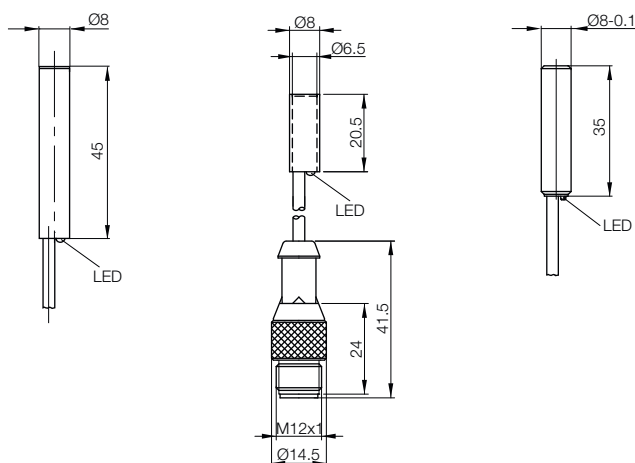



**SUPER**SHORTIES

M8x1	M8x1	M8x1	M8x1	M8x1
Flush	Flush	Flush	Flush	Flush
<b>1.5 mm</b>	<b>1.5 mm</b>	<b>1.5 mm</b>	<b>1.5 mm</b>	<b>1.5 mm</b>
0...1.2 mm	0...1.2 mm	0...1.2 mm	0...1.2 mm	0...1.2 mm
■	■	■	■	■
<b>BES0277</b>	<b>BES013N</b>	<b>BES013M</b>	<b>BES0147</b>	<b>BES0146</b>
BES M08EA-PSD15B-S49G	BES M08EC-PSC15B-S49G	BES M08EC-PSC15B-S04G	BES M08EE-PSC15B-S49G	BES M08EE-PSC15B-S04G
<b>BES0270</b>	<b>BES013K</b>		<b>BES0143</b>	<b>BES0142</b>
BES M08EA-POD15B-S49G	BES M08EC-POC15B-S49G		BES M08EE-POC15B-S49G	BES M08EE-POC15B-S04G
<b>BES026W</b>	<b>BES013J</b>		<b>BES013Z</b>	<b>BES013Y</b>
BES M08EA-NSD15B-S49G	BES M08EC-NSC15B-S49G		BES M08EE-NSC15B-S49G	BES M08EE-NSC15B-S04G
<b>BES026R</b>			<b>BES013T</b>	<b>BES013R</b>
BES M08EA-NOD15B-S49G			BES M08EE-NOC15B-S49G	BES M08EE-NOC15B-S04G
10...30 V DC	10...30 V DC	10...30 V DC	10...30 V DC	10...30 V DC
2.5 V	2.5 V	2.5 V	2.5 V	2.5 V
75 V DC	250 V AC (□)	250 V AC (□)	250 V AC (□)	250 V AC (□)
150 mA	200 mA	200 mA	200 mA	200 mA
Yes/Yes/Yes	Yes/Yes/Yes	Yes/Yes/Yes	Yes/Yes/Yes	Yes/Yes/Yes
-25...+70 °C	-25...+70 °C	-25...+70 °C	-25...+70 °C	-25...+70 °C
3 kHz	3 kHz	3 kHz	3 kHz	3 kHz
No	Yellow LED	Yellow LED	Yellow LED	Yellow LED
IP 67	IP 68 per BWN Pr. 20	IP 68 per BWN Pr. 20	IP 68 per BWN Pr. 20	IP 68 per BWN Pr. 20
CE, cULus	CE, cULus	CE, cULus	CE, cULus	CE, cULus
<b>Short design</b>				
Stainless steel	Stainless steel	Stainless steel	Stainless steel	Stainless steel
PBT	PBT	PBT	PBT	PBT
M8 connector, 3-pin	M8 connector, 3-pin	M12 connector, 4-pin	M8 connector, 3-pin	M12 connector, 4-pin

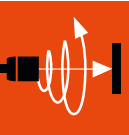

- Inductive Sensors
- Global DC 3-wire
- DC 3-/4-wire
- Cylinder Designs
- Block Designs
- DC 2-wire
- AC/DC 2-wire
- AC 2-wire
- Special Properties
- Analog Distance measurement
- Accessories

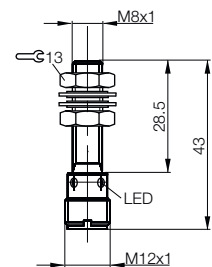
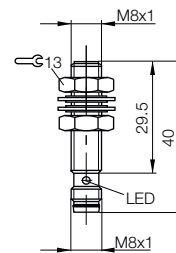
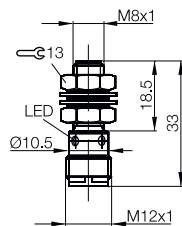
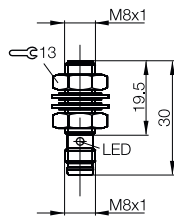
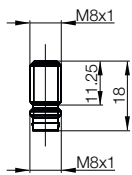

# DC 3-/4-wire Inductive Sensors

## Cylinder designs, M8x1



**SUPER**SHORTIES

Model		<b>M8x1</b>	<b>M8x1</b>	<b>M8x1</b>	
Installation type (observe instructions in the Basic Information chapter)		Flush	Flush	Flush	
Rated switching distance $s_n$		<b>1.5 mm</b>	<b>1.5 mm</b>	<b>1.5 mm</b>	
Assured switching distance $s_a$		0...1.2 mm	0...1.2 mm	0...1.2 mm	
Switching distance marking		■	■	■	
PNP, NO	<b>Ordering code</b>	<b>BES01AW</b>	<b>BES01PF</b>	<b>BES0272</b>	
	Part number	BES 516-324-S49-C	BES M08EH-PSC15B-S04G	BES M08EA-PSC15B-EP00,3-GS26	
PNP, NC	<b>Ordering code</b>	<b>BES01LR</b>	<b>BES01PE</b>		
	Part number	BES 516-377-S49-C	BES M08EH-POC15B-S04G		
NPN, NO	<b>Ordering code</b>	<b>BES01F5</b>	<b>BES01PC</b>		
	Part number	BES 516-343-S49-C	BES M08EH-NSC15B-S04G		
NPN, NC	<b>Ordering code</b>	<b>BES01LZ</b>	<b>BES01PA</b>		
	Part number	BES 516-378-S49-C	BES M08EH-NOC15B-S04G		
Supply voltage $U_s$		10...30 V DC	10...30 V DC	10...30 V DC	
Voltage drop $U_d$ at $I_o$ max.		2.5 V	2.5 V	2.5 V	
Rated insulation voltage $U_i$ (protection class)		250 V AC (□)	250 V AC (□)	75 V DC	
Rated operating current $I_o$		200 mA	200 mA	150 mA	
Polarity reversal protected/transposition protected/short-circuit protected		Yes/Yes/Yes	Yes/Yes/Yes	Yes/Yes/Yes	
Ambient temperature $T_a$		-25...+70 °C	-25...+70 °C	-25...+70 °C	
Switching frequency $f$ max.		3 kHz	3 kHz	3 kHz	
Output function indicator		Yellow LED	Yellow LED	Yellow LED	
Degree of protection as per IEC 60529		IP 68 per BWN Pr. 20	IP 68 per BWN Pr. 20	IP 67	
Approvals		CE, cULus	CE, cULus	CE, cULus	
Special properties				<b>Short design</b>	
Material	Housing	Stainless steel	Stainless steel	Stainless steel	
	Sensing surface	PBT	PBT	PBT	
Connection		M8 connector, 3-pin	M12 connector, 4-pin	0.3 m PUR cable with M5 connector, 4-pin	

Wiring diagrams, see page 958.  
The meaning of switching distance markings can be found on page 962.

**Additional cable lengths and PUR cable jacket material available on request**

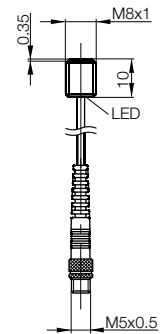
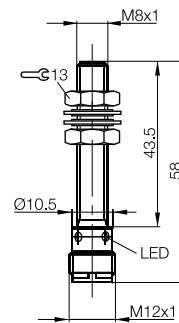
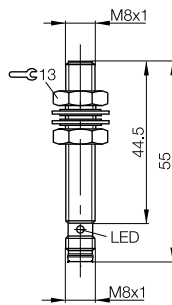

# DC 3-/4-wire Inductive Sensors Cylinder designs, M8x1



**SUPER**SHORTIES

M8x1	M8x1	M8x1	M8x1	M8x1
Flush	Flush	Flush	Flush	Flush
<b>1.5 mm</b>	<b>1.5 mm</b>	<b>1.5 mm</b>	<b>1.5 mm</b>	<b>1.5 mm</b>
0...1.2 mm	0...1.2 mm	0...1.2 mm	0...1.2 mm	0...1.2 mm
■	■	■	■	■
<b>BES0273</b>	<b>BES034Y</b>	<b>BES00NK</b>	<b>BES00N9</b>	<b>BES00MU</b>
BES M08EA-PSC15B-EP00,3-GS49	BES 516-324-SA44-C-S49-00,3	BES 516-324-E4-C-S49-00,3	BES 516-324-E4-C-S4-00,3	BES 516-324-E3-C-S49-00,3
<b>BES026T</b>				
BES M08EA-NSC15B-EP00,3-GS49				
10...30 V DC	10...30 V DC	10...30 V DC	10...30 V DC	10...30 V DC
2.5 V	2.5 V	2.5 V	2.5 V	2.5 V
75 V DC	75 V DC	250 V AC (□)	250 V AC (□)	250 V AC (□)
150 mA	200 mA	200 mA	200 mA	200 mA
Yes/Yes/Yes	Yes/Yes/Yes	Yes/Yes/Yes	Yes/Yes/Yes	Yes/Yes/Yes
-25...+70 °C	-25...+70 °C	-25...+70 °C	-25...+70 °C	-25...+70 °C
3 kHz	4 kHz	3 kHz	3 kHz	3 kHz
Yellow LED	Yellow LED	Yellow LED	Yellow LED	Yellow LED
IP 67	IP 67	IP 68 per BWN Pr. 20	IP 68 per BWN Pr. 20	IP 68 per BWN Pr. 20
CE, cULus	CE	CE, cULus	CE, cULus	CE, cULus
<b>Short design</b>				
Stainless steel	Stainless steel	Stainless steel	Stainless steel	Stainless steel
PBT	PBT	PBT	PBT	PBT
0.3 m PUR cable with M8 connector, 3-pin	0.3 m PUR cable with M8 connector, 3-pin	0.3 m PUR cable with M8 connector, 3-pin	0.3 m PUR cable with M12 connector, 4-pin	0.3 m PUR cable with M8 connector, 3-pin

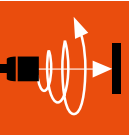

Inductive Sensors  
Global DC 3-wire  
DC 3-/4-wire  
Cylinder Designs  
Block Designs  
DC 2-wire  
AC/DC 2-wire  
AC 2-wire  
Special Properties  
Analog Distance measurement  
Accessories

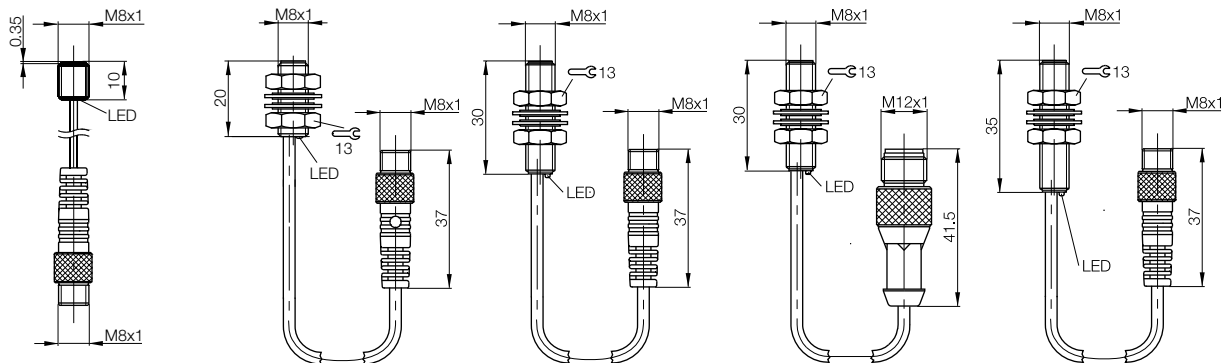

# DC 3-/4-wire Inductive Sensors

## Cylinder designs, M8x1



**SUPER**SHORTIES

Model		<b>M8x1</b>	<b>M8x1</b>	<b>M8x1</b>
Installation type (observe instructions in the Basic Information chapter)		Flush	Flush	Flush
Rated switching distance $s_n$		<b>1.5 mm</b>	<b>1.5 mm</b>	<b>1.5 mm</b>
Assured switching distance $s_a$		0...1.2 mm	0...1.2 mm	0...1.2 mm
Switching distance marking		■	■	■
PNP, NO	<b>Ordering code</b>	<b>BES00MT</b>	<b>BES01AL</b>	<b>BES026M</b>
	Part number	BES 516-324-E3-C-S4-00,3	BES 516-324-EO-C-S49-00,3	BES M08E60-PSC15B-EP02
PNP, NC	<b>Ordering code</b>	<b>BES010N</b>	<b>BES01LN</b>	<b>BES026K</b>
	Part number	BES 516-377-E3-C-S4-PU-00,3	BES 516-377-EO-C-S49-00,3	BES M08E60-POC15B-EP02
NPN, NO	<b>Ordering code</b>		<b>BES01F4</b>	<b>BES026J</b>
	Part number		BES 516-343-EO-C-S49-00,3	BES M08E60-NSC15B-EP02
NPN, NC	<b>Ordering code</b>			<b>BES026H</b>
	Part number			BES M08E60-NOC15B-EP02
Supply voltage $U_s$		10...30 V DC	10...30 V DC	10...30 V DC
Voltage drop $U_d$ at $I_o$ max.		2.5 V	2.5 V	2.5 V
Rated insulation voltage $U_i$ (protection class)		250 V AC (II)	250 V AC (II)	75 V DC
Rated operating current $I_o$		200 mA	200 mA	150 mA
Polarity reversal protected/transposition protected/short-circuit protected		Yes/Yes/Yes	Yes/Yes/Yes	Yes/Yes/Yes
Ambient temperature $T_a$		-25...+70 °C	-25...+70 °C	-25...+70 °C
Switching frequency $f$ max.		3 kHz	3 kHz	3 kHz
Output function indicator		Yellow LED	Yellow LED	Yellow LED
Degree of protection as per IEC 60529		IP 68 per BWN Pr. 20	IP 68 per BWN Pr. 20	IP 67
Approvals		CE, cULus	CE, cULus	CE, cULus
Special properties				<b>Short design</b>
Material	Housing	Stainless steel	Stainless steel	Stainless steel
	Sensing surface	PBT	PBT	PBT
Connection		0.3 m PUR cable with M12 connector, 4-pin	0.3 m PUR cable with M8 connector, 3-pin	2 m PUR cable, 3x0.073 mm <sup>2</sup>

Wiring diagrams, see page 958.  
The meaning of switching distance markings can be found on page 962.

**Additional cable lengths and PUR cable jacket material available on request**

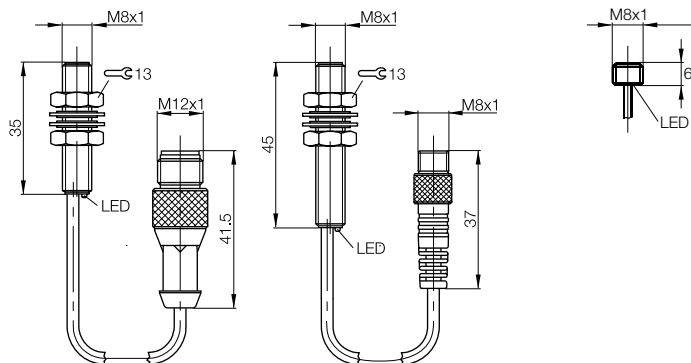



# DC 3-/4-wire Inductive Sensors Cylinder designs, M8x1



**SUPER**SHORTIES

M8x1	M8x1	M8x1	M8x1	M8x1
Flush	Flush	Flush	Flush	Flush
<b>1.5 mm</b>	<b>1.5 mm</b>	<b>1.5 mm</b>	<b>1.5 mm</b>	<b>1.5 mm</b>
0...1.2 mm	0...1.2 mm	0...1.2 mm	0...1.2 mm	0...1.2 mm
■	■	■	■	■
<b>BES0275</b>	<b>BES034P</b>	<b>BES00MY</b>		<b>BES014K</b>
BES M08EA-PSC15B-EP02	BES 516-324-SA44-C-02	BES 516-324-E4-C-02		BES M08EF-PSC15B-BP02
<b>BES026Y</b>		<b>BES010T</b>	<b>BES010K</b>	<b>BES014H</b>
BES M08EA-POC15B-EP02		BES 516-377-E4-C-02	BES 516-377-E3-C-PU-02	BES M08EF-POC15B-BP02
<b>BES026U</b>		<b>BES00TL</b>		<b>BES03J6</b>
BES M08EA-NSC15B-EP02		BES 516-343-E4-C-02		BES M08EF-NSC15B-BP02
<b>BES026N</b>				<b>BES014C</b>
BES M08EA-NOC15B-EP02				BES M08EF-NOC15B-BP02
10...30 V DC	10...30 V DC	10...30 V DC	10...30 V DC	10...30 V DC
2.5 V	2.5 V	2.5 V	2.5 V	2.5 V
75 V DC	75 V DC	250 V AC (□)	250 V AC (□)	250 V AC (□)
150 mA	200 mA	200 mA	200 mA	200 mA
Yes/Yes/Yes	Yes/Yes/Yes	Yes/Yes/Yes	Yes/Yes/Yes	Yes/Yes/Yes
-25...+70 °C	-25...+70 °C	-25...+70 °C	-25...+70 °C	-25...+70 °C
3 kHz	4 kHz	3 kHz	3 kHz	3 kHz
Yellow LED	Yellow LED	Yellow LED	Yellow LED	Yellow LED
IP 67	IP 67	IP 68 per BWN Pr. 20	IP 68 per BWN Pr. 20	IP 68 per BWN Pr. 20
CE, cULus	CE	CE, cULus	CE, cULus	CE, cULus
<b>Short design</b>				
Stainless steel	Stainless steel	Stainless steel	Stainless steel	Stainless steel
PBT	PBT	PBT	PBT	PBT
2 m PUR cable, 3x0.073 mm <sup>2</sup>	2 m PVC cable, 3x0.14 mm <sup>2</sup>	2 m PVC cable, 3x0.14 mm <sup>2</sup>	2 m PUR cable, 3x0.14 mm <sup>2</sup>	2 m PUR cable, 3x0.14 mm <sup>2</sup>

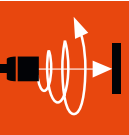

Inductive Sensors  
Global DC 3-wire  
DC 3-/4-wire  
Cylinder Designs  
Block Designs  
DC 2-wire  
AC/DC 2-wire  
AC 2-wire  
Special Properties  
Analog Distance measurement  
Accessories

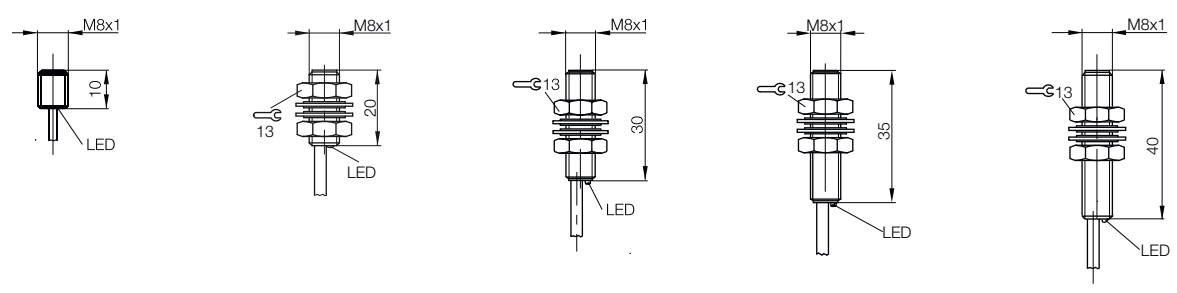

# DC 3-/4-wire Inductive Sensors

## Cylinder designs, M8x1



Model		<b>M8x1</b>	<b>M8x1</b>	
Installation type (observe instructions in the Basic Information chapter)		Flush	Flush	
Rated switching distance $s_n$		<b>1.5 mm</b>	<b>1.5 mm</b>	
Assured switching distance $s_a$		0...1.2 mm	0...1.2 mm	
Switching distance marking		■	■	
PNP, NO	<b>Ordering code</b>	<b>BES01A7</b>	<b>BES01AC</b>	
	Part number	BES 516-324-EO-C-02	BES 516-324-EO-C-PU-02	
PNP, NC	<b>Ordering code</b>	<b>BES01LC</b>	<b>BES01LH</b>	
	Part number	BES 516-377-EO-C-02	BES 516-377-EO-C-PU-02	
NPN, NO	<b>Ordering code</b>	<b>BES01EY</b>	<b>BES01F1</b>	
	Part number	BES 516-343-EO-C-02	BES 516-343-EO-C-PU-02	
NPN, NC	<b>Ordering code</b>	<b>BES01LT</b>		
	Part number	BES 516-378-EO-C-02		
Supply voltage $U_s$		10...30 V DC	10...30 V DC	
Voltage drop $U_d$ at $I_o$ max.		2.5 V	2.5 V	
Rated insulation voltage $U_i$ (protection class)		250 V AC (□)	250 V AC (□)	
Rated operating current $I_o$		200 mA	200 mA	
Polarity reversal protected/transposition protected/short-circuit protected		Yes/Yes/Yes	Yes/Yes/Yes	
Ambient temperature $T_a$		-25...+70 °C	-25...+70 °C	
Switching frequency $f$ max.		3 kHz	3 kHz	
Output function indicator		Yellow LED	Yellow LED	
Degree of protection as per IEC 60529		IP 68 per BWN Pr. 20	IP 68 per BWN Pr. 20	
Approvals		CE, cULus	CE, cULus	
Special properties				
Material	Housing	Stainless steel	Stainless steel	
	Sensing surface	PBT	PBT	
Connection		2 m PVC cable, 3x0.14 mm <sup>2</sup>	2 m PUR cable, 3x0.14 mm <sup>2</sup>	

Wiring diagrams, see page 958.  
The meaning of switching distance markings can be found on page 962.

**Additional cable lengths and PUR cable jacket material available on request**

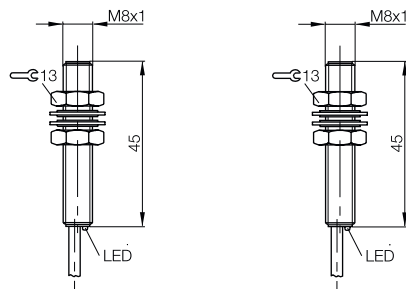



**SUPER**SHORTIES

M8x1	M8x1	M8x1	M8x1	M8x1
Flush	Flush	Flush	Flush	Flush
<b>2 mm</b>	<b>2 mm</b>	<b>2 mm</b>	<b>2 mm</b>	<b>2 mm</b>
0...1.6 mm	0...1.6 mm	0...1.6 mm	0...1.6 mm	0...1.4 mm
■ ■	■ ■	■ ■	■ ■	■ ■
<b>BES0278</b>	<b>BES013P</b>	<b>BES014A</b>	<b>BES0148</b>	<b>BES0149</b>
BES M08EA-PSD20B-S49G	BES M08EC-PSC20B-S49G	BES M08EE-PSC20B-S49G	BES M08EE-PSC20B-S04G	BES M08EE-PSC20B-S04G-101
	<b>BES013L</b>	<b>BES0145</b>	<b>BES0144</b>	
	BES M08EC-POC20B-S49G	BES M08EE-POC20B-S49G	BES M08EE-POC20B-S04G	
<b>BES01P1</b>		<b>BES0141</b>	<b>BES0140</b>	
BES M08EA-NSD20B-S49G		BES M08EE-NSC20B-S49G	BES M08EE-NSC20B-S04G	
		<b>BES013W</b>	<b>BES013U</b>	
		BES M08EE-NOC20B-S49G	BES M08EE-NOC20B-S04G	
10...30 V DC	10...30 V DC	10...30 V DC	10...30 V DC	10...30 V DC
2.5 V	2.5 V	2.5 V	2.5 V	2.5 V
75 V DC	250 V AC (□)	250 V AC (□)	250 V AC (□)	250 V AC (□)
150 mA	200 mA	200 mA	200 mA	200 mA
Yes/Yes/Yes	Yes/Yes/Yes	Yes/Yes/Yes	Yes/Yes/Yes	Yes/Yes/Yes
-25...+70 °C	-25...+70 °C	-25...+70 °C	-25...+70 °C	-25...+70 °C
3 kHz	1.5 kHz	1.5 kHz	1.5 kHz	1.5 kHz
No	Yellow LED	Yellow LED	Yellow LED	Yellow LED
IP 67	IP 68 per BWN Pr. 20	IP 68 per BWN Pr. 20	IP 68 per BWN Pr. 20	IP 68 per BWN Pr. 20
CE, cULus	CE, cULus	CE, cULus	CE, cULus	CE, cULus
<b>Short design</b>				
Stainless steel	Stainless steel	Stainless steel	Stainless steel	Stainless steel
PBT	PBT	PBT	PBT	With ceramic coating
M8 connector, 3-pin	M8 connector, 3-pin	M8 connector, 3-pin	M12 connector, 4-pin	M12 connector, 4-pin

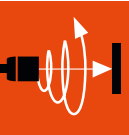

Inductive Sensors  
Global DC 3-wire  
DC 3-/4-wire  
Cylinder Designs  
Block Designs  
DC 2-wire  
AC/DC 2-wire  
AC 2-wire  
Special Properties  
Analog Distance measurement  
Accessories

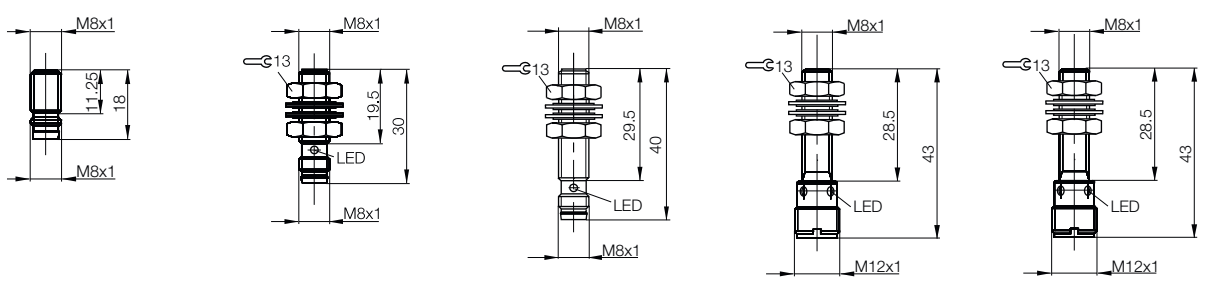

# DC 3-/4-wire Inductive Sensors

## Cylinder designs, M8x1



Model		<b>M8x1</b>	<b>M8x1</b>	<b>M8x1</b>	
Installation type (observe instructions in the Basic Information chapter)		Flush	Flush	Flush	
Rated switching distance $s_n$		<b>2 mm</b>	<b>2 mm</b>	<b>2 mm</b>	
Assured switching distance $s_a$		0...1.6 mm	0...1.4 mm	0...1.6 mm	
Switching distance marking		■ ■	■ ■	■ ■	
PNP, NO	<b>Ordering code</b>	<b>BES00P7</b>	<b>BES02P0</b>	<b>BES01AU</b>	
	Part number	BES 516-324-G-E5-C-S49	BES 516-324-SA96-G-E5-C-S49	BES 516-324-G-S49-C	
PNP, NC	<b>Ordering code</b>	<b>BES0113</b>		<b>BES01LP</b>	
	Part number	BES 516-377-G-E5-C-S49		BES 516-377-G-S49-C	
NPN, NO	<b>Ordering code</b>	<b>BES00TY</b>	<b>BES02P1</b>		
	Part number	BES 516-343-G-E5-C-S49	BES 516-343-SA96-G-E5-C-S49		
NPN, NC	<b>Ordering code</b>	<b>BES0118</b>			
	Part number	BES 516-378-G-E5-C-S49			
Supply voltage $U_s$		10...30 V DC	10...30 V DC	10...30 V DC	
Voltage drop $U_d$ at $I_e$ max.		2.5 V	2.5 V	2.5 V	
Rated insulation voltage $U_i$ (protection class)		250 V AC (□)	250 V AC (□)	250 V AC (□)	
Rated operating current $I_e$		200 mA	200 mA	200 mA	
Polarity reversal protected/transposition protected/short-circuit protected		Yes/Yes/Yes	Yes/Yes/Yes	Yes/Yes/Yes	
Ambient temperature $T_a$		-25...+70 °C	-25...+70 °C	-25...+70 °C	
Switching frequency $f$ max.		1.5 kHz	1.5 kHz	1.5 kHz	
Output function indicator		Yellow LED	Yellow LED	Yellow LED	
Degree of protection as per IEC 60529		IP 68 per BWN Pr. 20	IP 68 per BWN Pr. 20	IP 68 per BWN Pr. 20	
Approvals		CE, cULus	CE, cULus	CE, cULus	
Special properties					
Material	Housing	Stainless steel	Stainless steel	Stainless steel	
	Sensing surface	PBT	With ceramic coating	PBT	
Connection		M8 connector, 3-pin	M8 connector, 3-pin	M8 connector, 3-pin	

Wiring diagrams, see page 958.  
The meaning of switching distance markings can be found on page 962.

**Additional cable lengths and PUR cable jacket material available on request**

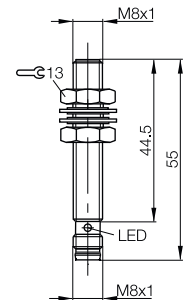
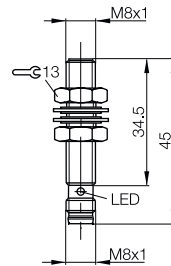
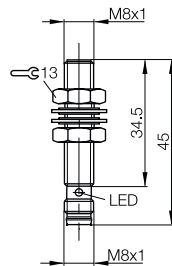

# DC 3-/4-wire Inductive Sensors Cylinder designs, M8x1



**SUPER**SHORTIES

M8x1	M8x1	M8x1	M8x1	M8x1
Flush	Flush	Flush	Flush	Flush
<b>2 mm</b>	<b>2 mm</b>	<b>2 mm</b>	<b>2 mm</b>	<b>2 mm</b>
0...1.6 mm	0...1.6 mm	0...1.6 mm	0...1.6 mm	0...1.4 mm
■ ■	■ ■	■ ■	■ ■	■ ■
<b>BES01PH</b>	<b>BES0276</b>	<b>BES00P4</b>	<b>BES00P2</b>	<b>BES02P5</b>
BES M08EH-PSC20B-S04G	BES M08EA-PSC20B-EP00,3-GS49	BES 516-324-G-E4-C-S49-00,3	BES 516-324-G-E4-C-S4-00,3	BES 516-324-SA96-G-E4-C-S4-00,3
		<b>BES0112</b>		
		BES 516-377-G-E4-C-S49-00,3		
<b>BES0118</b>				
BES 516-378-G-E5-C-S49				
10...30 V DC	10...30 V DC	10...30 V DC	10...30 V DC	10...30 V DC
2.5 V	2.5 V	2.5 V	2.5 V	2.5 V
250 V AC (□)	75 V DC	250 V AC (□)	250 V AC (□)	250 V AC (□)
200 mA	150 mA	200 mA	200 mA	200 mA
Yes/Yes/Yes	Yes/Yes/Yes	Yes/Yes/Yes	Yes/Yes/Yes	Yes/Yes/Yes
-25...+70 °C	-25...+70 °C	-25...+70 °C	-25...+70 °C	-25...+70 °C
1.5 kHz	3 kHz	1.5 kHz	1.5 kHz	1.5 kHz
Yellow LED	Yellow LED	Yellow LED	Yellow LED	Yellow LED
IP 68 per BWN Pr. 20	IP 67	IP 68 per BWN Pr. 20	IP 68 per BWN Pr. 20	IP 68 per BWN Pr. 20
CE, cULus	CE, cULus	CE, cULus	CE, cULus	CE, cULus
	<b>Short design</b>			
Stainless steel	Stainless steel	Stainless steel	Stainless steel	Stainless steel
PBT	PBT	PBT	PBT	With ceramic coating
M12 connector, 4-pin	0.3 m PUR cable with M8 connector, 3-pin	0.3 m PUR cable with M8 connector, 3-pin	0.3 m PUR cable with M12 connector, 4-pin	0.3 m PUR cable with M12 connector, 4-pin

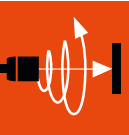

Inductive Sensors  
Global DC 3-wire  
DC 3-/4-wire  
Cylinder Designs  
Block Designs  
DC 2-wire  
AC/DC 2-wire  
AC 2-wire  
Special Properties  
Analog Distance measurement  
Accessories

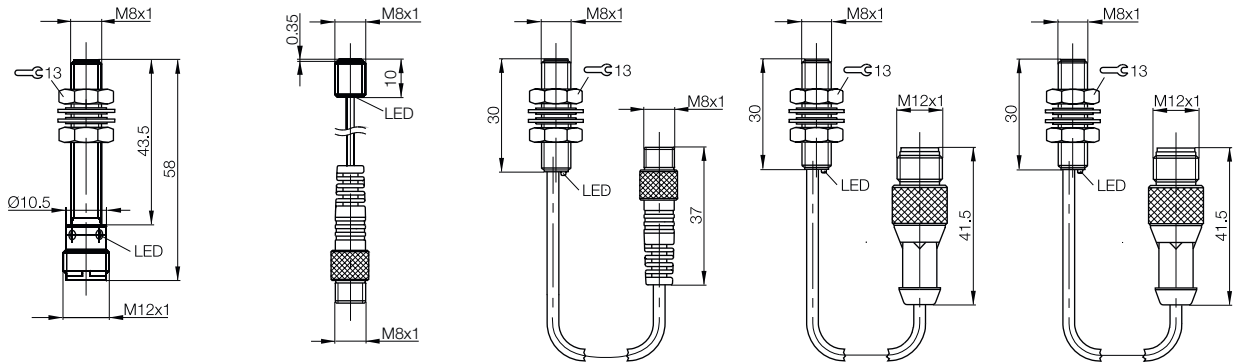

# DC 3-/4-wire Inductive Sensors

## Cylinder designs, M8x1



**SUPER**SHORTIES

Model		<b>M8x1</b>	<b>M8x1</b>	<b>M8x1</b>	
Installation type (observe instructions in the Basic Information chapter)		Flush	Flush	Flush	
Rated switching distance $s_n$		<b>2 mm</b>	<b>2 mm</b>	<b>2 mm</b>	
Assured switching distance $s_a$		0...1.6 mm	0...1.6 mm	0...1.6 mm	
Switching distance marking		■ ■	■ ■	■ ■	
PNP, NO	<b>Ordering code</b>	<b>BES03TU</b>	<b>BES01AT</b>		
	Part number	BES M08EF-PSC20B-BP00,3-GS49	BES 516-324-G-EO-C-S49-01		
PNP, NC	<b>Ordering code</b>			<b>BES026Z</b>	
	Part number			BES M08EA-POC20B-EP02	
NPN, NC	<b>Ordering code</b>			<b>BES026P</b>	
	Part number			BES M08EA-NOC20B-EP02	
NPN, NC	<b>Ordering code</b>				
	Part number				
Supply voltage $U_s$		10...30 V DC	10...30 V DC	10...30 V DC	
Voltage drop $U_d$ at $I_o$ max.		2.5 V	2.5 V	2.5 V	
Rated insulation voltage $U_i$ (protection class)		250 V AC (II)	250 V AC (II)	75 V DC	
Rated operating current $I_o$		200 mA	200 mA	150 mA	
Polarity reversal protected/transposition protected/short-circuit protected		Yes/Yes/Yes	Yes/Yes/Yes	Yes/Yes/Yes	
Ambient temperature $T_a$		-25...+70 °C	-25...+70 °C	-25...+70 °C	
Switching frequency $f$ max.		1.5 kHz	1.5 kHz	3 kHz	
Output function indicator		Yellow LED	Yellow LED	Yellow LED	
Degree of protection as per IEC 60529		IP 68 per BWN Pr. 20	IP 68 per BWN Pr. 20	IP 67	
Approvals		CE, cULus	CE, cULus	CE, cULus	
Special properties				<b>Short design</b>	
Material	Housing	Stainless steel	Stainless steel	Stainless steel	
	Sensing surface	PBT	PBT	PBT	
Connection		0.3 m PUR cable with M8 connector, 3-pin	1 m PUR cable with M8 connector, 3-pin	2 m PUR cable, 3x0.073 mm <sup>2</sup>	

Wiring diagrams, see page 958.  
The meaning of switching distance markings can be found on page 962.

**Additional cable lengths and PUR cable jacket material available on request**

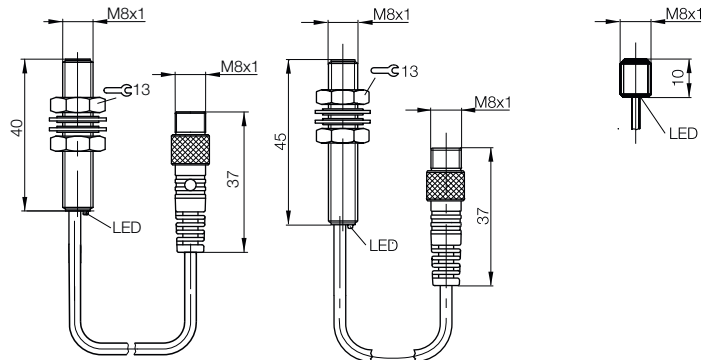

# DC 3-/4-wire Inductive Sensors

## Cylinder designs, M8x1

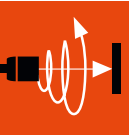

Inductive Sensors  
Global DC 3-wire  
DC 3-/4-wire  
Cylinder Designs  
Block Designs  
DC 2-wire  
AC/DC 2-wire  
AC 2-wire  
Special Properties  
Analog Distance measurement  
Accessories



M8x1	M8x1	M8x1	M8x1	M8x1
Flush	Flush	Flush	Flush	Flush
<b>2 mm</b>	<b>2 mm</b>	<b>2 mm</b>	<b>2 mm</b>	<b>2 mm</b>
0...1.6 mm	0...1.6 mm	0...1.6 mm	0...1.6 mm	0...1.6 mm
■ ■	■ ■	■ ■	■ ■	■ ■
<b>BES00NR</b>	<b>BES00NY</b>	<b>BES014L</b>	<b>BES01AM</b>	<b>BES01AN</b>
BES 516-324-G-E4-C-02	BES 516-324-G-E4-C-PU-02	BES M08EF-PSC20B-BP02	BES 516-324-G-EO-C-02	BES 516-324-G-EO-C-PU-02
<b>BES010Y</b>	<b>BES010Z</b>	<b>BES014J</b>		
BES 516-377-G-E4-C-02	BES 516-377-G-E4-C-PU-02	BES M08EF-POC20B-BP02		
<b>BES00TT</b>		<b>BES014F</b>		
BES 516-343-G-E4-C-02		BES M08EF-NSC20B-BP02		
<b>BES0116</b>		<b>BES014E</b>		
BES 516-378-G-E4-C-02		BES M08EF-NOC20B-BP02		
10...30 V DC	10...30 V DC	10...30 V DC	10...30 V DC	10...30 V DC
2.5 V	2.5 V	2.5 V	2.5 V	2.5 V
250 V AC (□)	250 V AC (□)	250 V AC (□)	250 V AC (□)	250 V AC (□)
200 mA	200 mA	200 mA	200 mA	200 mA
Yes/Yes/Yes	Yes/Yes/Yes	Yes/Yes/Yes	Yes/Yes/Yes	Yes/Yes/Yes
-25...+70 °C	-25...+70 °C	-25...+70 °C	-25...+70 °C	-25...+70 °C
1.5 kHz	1.5 kHz	1.5 kHz	1.5 kHz	1.5 kHz
Yellow LED	Yellow LED	Yellow LED	Yellow LED	Yellow LED
IP 68 per BWN Pr. 20	IP 68 per BWN Pr. 20	IP 68 per BWN Pr. 20	IP 68 per BWN Pr. 20	IP 68 per BWN Pr. 20
CE, cULus	CE, cULus	CE, cULus	CE, cULus	CE, cULus
Stainless steel	Stainless steel	Stainless steel	Stainless steel	Stainless steel
PBT	PBT	PBT	PBT	PBT
2 m PVC cable, 3x0.14 mm <sup>2</sup>	2 m PUR cable, 3x0.14 mm <sup>2</sup>	2 m PUR cable, 3x0.14 mm <sup>2</sup>	2 m PVC cable, 3x0.14 mm <sup>2</sup>	2 m PUR cable, 3x0.14 mm <sup>2</sup>

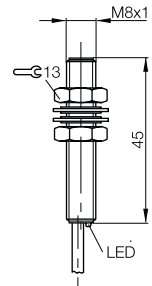
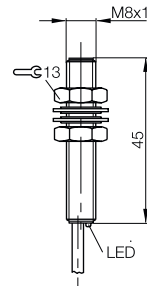
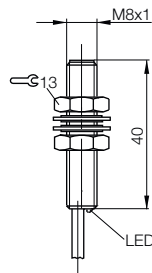
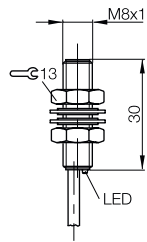
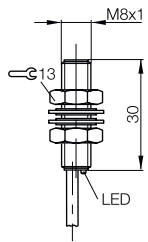

# DC 3-/4-wire Inductive Sensors

## Cylinder designs, M8x1



TRIPLEPROX



TRIPLEPROX



TRIPLEPROX

Model		<b>M8x1</b>	<b>M8x1</b>	<b>M8x1</b>
Installation type (observe instructions in the Basic Information chapter)		Quasi-flush	Quasi-flush	Quasi-flush
Rated switching distance $s_n$		<b>3 mm</b>	<b>3 mm</b>	<b>3 mm</b>
Assured switching distance $s_a$		0...2.4 mm	0...2.4 mm	0...2.2 mm
Switching distance marking		■■■	■■■	■■■
PNP, NO	<b>Ordering code</b>	<b>BES02WA</b>	<b>BES02W9</b>	<b>BES02PW</b>
	Part number	BES M08MH1-PSC30B-S49G	BES M08MH1-PSC30B-S04G	BES M08MH1-PSC30B-S04G-101
PNP, NC	<b>Ordering code</b>			
	Part number			
NPN, NO	<b>Ordering code</b>	<b>BES02W8</b>	<b>BES02W7</b>	
	Part number	BES M08MH1-NSC30B-S49G	BES M08MH1-NSC30B-S04G	
Supply voltage $U_s$		10...30 V DC	10...30 V DC	10...30 V DC
Voltage drop $U_d$ at $I_e$ max.		2 V	2 V	2 V
Rated insulation voltage $U_i$ (protection class)		75 V DC	75 V DC	75 V DC
Rated operating current $I_e$		200 mA	200 mA	200 mA
Polarity reversal protected/transposition protected/short-circuit protected		Yes/Yes/Yes	Yes/Yes/Yes	Yes/Yes/Yes
Ambient temperature $T_a$		-25...+70 °C	-25...+70 °C	-25...+70 °C
Switching frequency $f$ max.		1 kHz	1 kHz	1 kHz
Output function indicator		Yellow LED	Yellow LED	Yellow LED
Degree of protection as per IEC 60529		IP 67	IP 67	IP 67
Approvals		CE	CE	CE
Special properties		<b>Large switching distance</b>	<b>Large switching distance</b>	<b>Large switching distance</b>
Material	Housing	Brass-coated	Brass-coated	Brass-coated
	Sensing surface	PBT	PBT	With ceramic coating
Connection		M8 connector, 3-pin	M12 connector, 4-pin	M12 connector, 4-pin

Wiring diagrams, see page 958.  
The meaning of switching distance markings can be found on page 962.

**Additional cable lengths and PUR cable jacket material available on request**

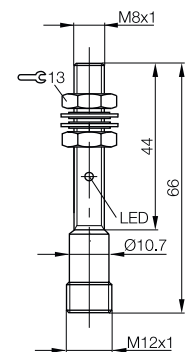
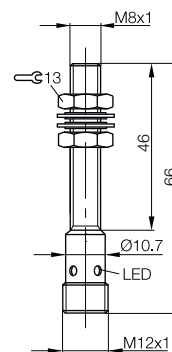
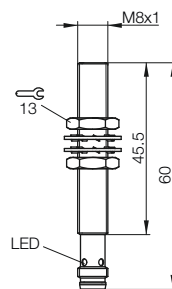





HYPERPROX		HYPERPROX		HYPERPROX	
<b>M8x1</b>	Quasi-flush	<b>M8x1</b>	Quasi-flush	<b>M8x1</b>	Quasi-flush
<b>4 mm</b>	0...2.9 mm	<b>4 mm</b>	0...2.9 mm	<b>4 mm</b>	0...2.9 mm
■■■■	■■■■	■■■■	■■■■	■■■■	■■■■
<b>BES01ZW</b>	<b>BES003R</b>	<b>BES01ZU</b>			
BES M08MI-PSC40B-S49G	BES M08MI-PSC40B-BP00,3-GS49	BES M08MI-PSC40B-BP00,2-GS04			
<b>BES01ZT</b>		<b>BES01ZR</b>			
BES M08MI-NSC40B-S49G		BES M08MI-NSC40B-BP00,2-GS04			
10...30 V DC	10...30 V DC	10...30 V DC			
2.8 V	2.8 V	2.8 V			
75 V DC	75 V DC	75 V DC			
200 mA	200 mA	200 mA			
Yes/Yes/Yes	Yes/Yes/Yes	Yes/Yes/Yes			
0...+60 °C	0...+60 °C	0...+60 °C			
800 Hz	800 Hz	800 Hz			
Yellow LED	Yellow LED	Yellow LED			
IP 67	IP 67	IP 67			
CE, cULus	CE, cULus	CE, cULus			
<b>Large switching distance</b>	<b>Large switching distance</b>	<b>Large switching distance</b>			
Brass-coated	Brass-coated	Brass-coated			
PBT	PBT	PBT			
M8 connector, 3-pin	0.3 m PUR cable with M8 connector, 3-pin	0.2 m PUR cable with M12 connector, 4-pin			

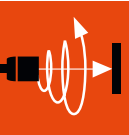

- Inductive Sensors
- Global DC 3-wire
- DC 3-/4-wire
- Cylinder Designs
- Block Designs
- DC 2-wire
- AC/DC 2-wire
- AC 2-wire
- Special Properties
- Analog Distance measurement
- Accessories

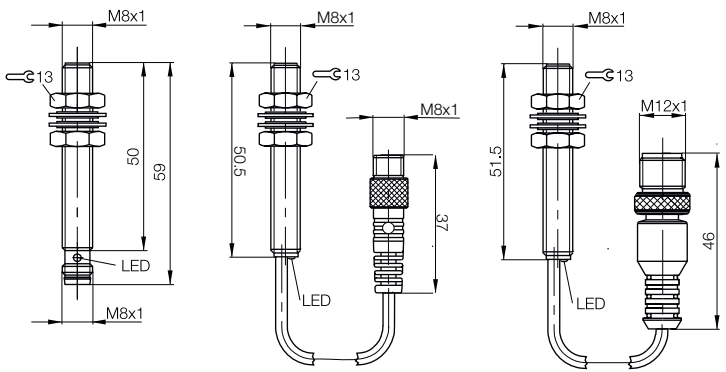

# DC 3-/4-wire Inductive Sensors

## Cylinder designs, M8x1



Model		<b>M8x1</b>	<b>M8x1</b>	<b>M8x1</b>
Installation type (observe instructions in the Basic Information chapter)		Not flush	Not flush	Not flush
Rated switching distance $s_n$		<b>2.5 mm</b>	<b>2.5 mm</b>	<b>2.5 mm</b>
Assured switching distance $s_a$		0...2 mm	0...2 mm	0...2 mm
Switching distance marking		■	■	■
PNP, NO	<b>Ordering code</b>	<b>BES01P3</b>	<b>BES01M6</b>	<b>BES01P8</b>
	Part number	BES M08ED-PSC25F-S04G	BES 516-383-S49-C	BES M08EG-PSC25F-S04G
PNP, NC	<b>Ordering code</b>			<b>BES01P6</b>
	Part number			BES M08EG-POC25F-S04G
NPN, NO	<b>Ordering code</b>	<b>BES01P2</b>		<b>BES01P5</b>
	Part number	BES M08ED-NSC25F-S04G		BES M08EG-NSC25F-S04G
NPN, NC	<b>Ordering code</b>			
	Part number			
Supply voltage $U_s$		10...30 V DC	10...30 V DC	10...30 V DC
Voltage drop $U_d$ at $I_e$ max.		2.5 V	2.5 V	2.5 V
Rated insulation voltage $U_i$ (protection class)		250 V AC (□)	250 V AC (□)	250 V AC (□)
Rated operating current $I_e$		200 mA	200 mA	200 mA
Polarity reversal protected/transposition protected/short-circuit protected		Yes/Yes/Yes	Yes/Yes/Yes	Yes/Yes/Yes
Ambient temperature $T_a$		-25...+70 °C	-25...+70 °C	-25...+70 °C
Switching frequency $f$ max.		2 kHz	2 kHz	2 kHz
Output function indicator		Yellow LED	Yellow LED	Yellow LED
Degree of protection as per IEC 60529		IP 68 per BWN Pr. 20	IP 68 per BWN Pr. 20	IP 68 per BWN Pr. 20
Approvals		CE, cULus	CE, cULus	CE, cULus
Special properties				
Material	Housing	Stainless steel	Stainless steel	Stainless steel
	Sensing surface	PBT	PBT	PBT
Connection		M12 connector, 4-pin	M8 connector, 3-pin	M12 connector, 4-pin

Wiring diagrams, see page 958.  
The meaning of switching distance markings can be found on page 962.

**Additional cable lengths and PUR cable jacket material available on request**

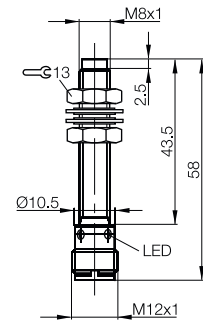
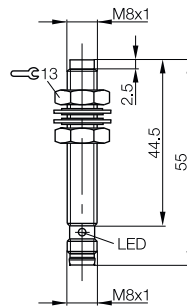
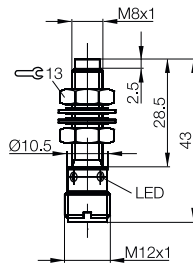

# DC 3-/4-wire Inductive Sensors Cylinder designs, M8x1



<b>M8x1</b> Not flush <b>2.5 mm</b> 0...2 mm ■	<b>M8x1</b> Not flush <b>2.5 mm</b> 0...2 mm ■	<b>M8x1</b> Not flush <b>2.5 mm</b> 0...2 mm ■	<b>M8x1</b> Not flush <b>2.5 mm</b> 0...2 mm ■	
		<b>BES011A</b> BES 516-383-E4-C-02	<b>BES01M0</b> BES 516-383-EO-C-02	
<b>BES011U</b> BES 516-384-E4-C-S49-00.2	<b>BES011MA</b> BES 516-384-EO-C-S49-00.2	<b>BES011M</b> BES 516-384-E4-C-02	<b>BES01M7</b> BES 516-384-EO-C-02	
10...30 V DC 2.5 V 250 V AC (□) 200 mA Yes/Yes/Yes -25...+70 °C 2 kHz Yellow LED IP 67 CE, cULus	10...30 V DC 2.5 V 250 V AC (□) 200 mA Yes/Yes/Yes -25...+70 °C 2 kHz Yellow LED IP 67 CE, cULus	10...30 V DC 2.5 V 250 V AC (□) 200 mA Yes/Yes/Yes -25...+70 °C 2 kHz Yellow LED IP 68 per BWN Pr. 20 CE, cULus	10...30 V DC 2.5 V 250 V AC (□) 200 mA Yes/Yes/Yes -25...+70 °C 2 kHz Yellow LED IP 68 per BWN Pr. 20 CE, cULus	
Stainless steel PBT	Stainless steel PBT	Stainless steel PBT	Stainless steel PBT	
0.2 m PVC cable with M8 connector, 3-pin	0.2 m PVC cable with M8 connector, 3-pin	2 m PVC cable, 3x0.14 mm <sup>2</sup>	2 m PVC cable, 3x0.14 mm <sup>2</sup>	

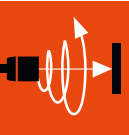

Inductive Sensors  
Global DC 3-wire  
DC 3-/4-wire  
Cylinder Designs  
Block Designs  
DC 2-wire  
AC/DC 2-wire  
AC 2-wire  
Special Properties  
Analog Distance measurement  
Accessories

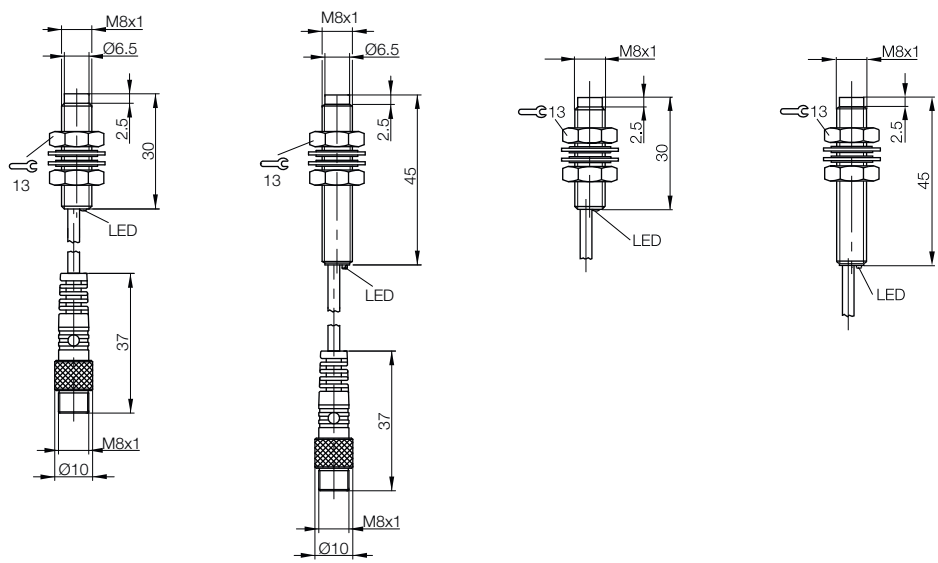

# DC 3-/4-wire Inductive Sensors

## Cylinder designs, M8x1



TRIPLEPROX

Model		<b>M8x1</b>	<b>M8x1</b>	<b>M8x1</b>	
Installation type (observe instructions in the Basic Information chapter)		Not flush	Not flush	Not flush	
Rated switching distance $s_n$		<b>4 mm</b>	<b>4 mm</b>	<b>6 mm</b>	
Assured switching distance $s_a$		0...3.2 mm	0...3.2 mm	0...4.8 mm	
Switching distance marking		■ ■	■ ■	■ ■ ■	
PNP, NO	<b>Ordering code</b>	<b>BES014M</b>	<b>BES01P9</b>	<b>BES02W4</b>	
	Part number	BES M08EF-PSC40F-S49G	BES M08EG1-PSC40F-S04G	BES M08MG1-PSC60F-S49G	
PNP, NC	<b>Ordering code</b>			<b>BES02W2</b>	
	Part number			BES M08MG1-POC60F-S49G	
NPN, NO	<b>Ordering code</b>				
	Part number				
NPN, NC	<b>Ordering code</b>			<b>BES02UZ</b>	
	Part number			BES M08MG1-NOC60F-S49G	
Supply voltage $U_s$		10...30 V DC	10...30 V DC	10...30 V DC	
Voltage drop $U_d$ at $I_e$ max.		2.5 V	2.5 V	2 V	
Rated insulation voltage $U_i$ (protection class)		250 V AC (II)	250 V AC (II)	75 V DC	
Rated operating current $I_e$		200 mA	200 mA	200 mA	
Polarity reversal protected/transposition protected/short-circuit protected		Yes/Yes/Yes	Yes/Yes/Yes	Yes/Yes/Yes	
Ambient temperature $T_a$		-25...+70 °C	-25...+70 °C	-25...+70 °C	
Switching frequency $f$ max.		1.5 kHz	5 kHz	500 Hz	
Output function indicator		Yellow LED	Yellow LED	Yellow LED	
Degree of protection as per IEC 60529		IP 68 per BWN Pr. 20	IP 68 per BWN Pr. 20	IP 67	
Approvals		CE, cULus	CE, cULus	CE	
Special properties				<b>Large switching distance</b>	
Material	Housing	Stainless steel	Stainless steel	Brass-coated	
	Sensing surface	PBT	PBT	PBT	
Connection		M8 connector, 3-pin	M12 connector, 4-pin	M8 connector, 3-pin	

Wiring diagrams, see page 958.  
The meaning of switching distance markings can be found on page 962.

**Additional cable lengths and PUR cable jacket material available on request**

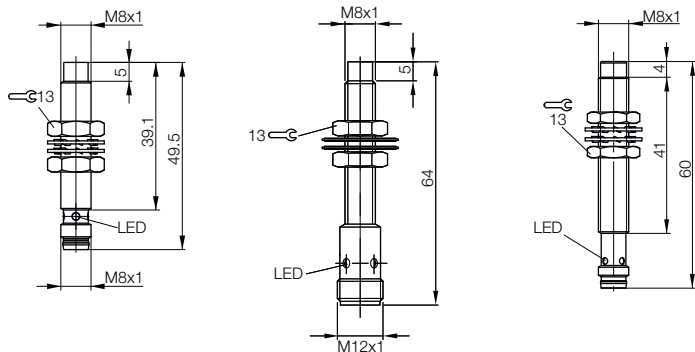

# DC 3-/4-wire Inductive Sensors

## Cylinder designs, M8x1



**TRIPLEPROX**



**SUPERSHORTIES**

**SUPERSHORTIES**

<b>M8x1</b>		<b>Ø11x12 mm</b>		<b>Ø11x17 mm</b>	
Not flush		Flush		Not flush	
<b>6 mm</b>		<b>4 mm</b>		<b>6 mm</b>	
0...4.8 mm		0...3.2 mm		0...4.8 mm	
■■■		■■		■■	
<b>BES02W3</b>		<b>BES047J</b>		<b>BES047R</b>	
BES M08MG1-PSC60F-S04G		BES G11EA-PSC40B-EP00,3-GS04		BES G11EA-PSC60F-EP00,3-GS04	
<b>BES02W0</b>					
BES M08MG1-NSC60F-S04G					
10...30 V DC		10...30 V DC		10...30 V DC	
2 V		2.5 V		2.5 V	
75 V DC		75 V AC (□)		75 V AC (□)	
200 mA		100 mA		100 mA	
Yes/Yes/Yes		Yes/Yes/Yes		Yes/Yes/Yes	
-25...+70 °C		-40...+85 °C		-40...+85 °C	
500 Hz		2 kHz		2 kHz	
Yellow LED		Yellow LED		Yellow LED	
IP 67		IP 67		IP 67	
CE		CE, cULus		CE, cULus	
<b>Large switching distance</b>		<b>Short design</b>		<b>Short design</b>	
Brass-coated		Stainless steel		Stainless steel	
PBT		LCP		LCP	
M12 connector, 4-pin		M12 connector, 4-pin		M12 connector, 4-pin	

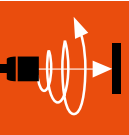

- Inductive Sensors
- Global DC 3-wire
- DC 3-/4-wire
- Cylinder Designs
- Block Designs
- DC 2-wire
- AC/DC 2-wire
- AC 2-wire
- Special Properties
- Analog Distance measurement
- Accessories

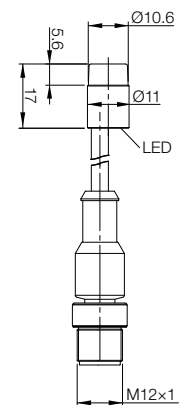
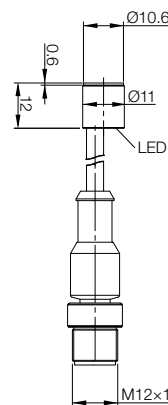
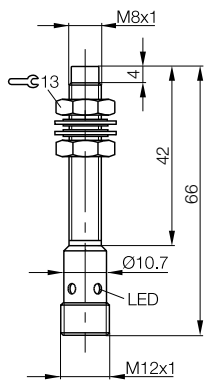

# DC 3-/4-wire Inductive Sensors

## Cylinder designs, M12x1



Model		<b>M12x1</b>	<b>M12x1</b>	<b>M12x1</b>	
Installation type (observe instructions in the Basic Information chapter)		Flush	Flush	Flush	
Rated switching distance $s_n$		<b>2 mm</b>	<b>2 mm</b>	<b>2 mm</b>	
Assured switching distance $s_a$		0...1.6 mm	0...1.6 mm	0...1.6 mm	
Switching distance marking		■	■	■	
PNP, NO	<b>Ordering code</b>	<b>BES00PK</b>	<b>BES02EL</b>	<b>BES01C8</b>	
	Part number	BES 516-325-E5-C-S4	BES 515-325-S4-C	BES 516-325-S4-C	
PNP, NC	<b>Ordering code</b>	<b>BES00YT</b>	<b>BES01K6</b>		
	Part number	BES 516-370-E5-C-S4	BES 516-370-S4-C		
PNP, complementary	<b>Ordering code</b>			<b>BES0161</b>	
	Part number			BES 516-113-S4-C	
NPN, NO	<b>Ordering code</b>	<b>BES00T5</b>	<b>BES01EN</b>		
	Part number	BES 516-329-E5-C-S4	BES 516-329-S4-C		
NPN, NC	<b>Ordering code</b>	<b>BES010A</b>	<b>BES01LA</b>		
	Part number	BES 516-375-E5-C-S4	BES 516-375-S4-C		
NPN, complementary	<b>Ordering code</b>			<b>BES016E</b>	
	Part number			BES 516-118-S4-C	
Supply voltage $U_S$		10...30 V DC	10...30 V DC	10...30 V DC	
Voltage drop $U_d$ at $I_e$ max.		2 V	1.5 V	1.5 V	
Rated insulation voltage $U_i$ (protection class)		250 V AC (□)	250 V AC (□)	250 V AC (□)	
Rated operating current $I_e$		200 mA	200 mA	200 mA	
Polarity reversal protected/transposition protected/short-circuit protected		Yes/Yes/Yes	Yes/Yes/Yes	Yes/Yes/Yes	
Ambient temperature $T_a$		-25...+70 °C	-25...+70 °C	-40...+85 °C	
Switching frequency $f$ max.		5 kHz	3 kHz	2.5 kHz	
Output function indicator		Yellow LED	Yellow LED	Yellow LED	
Degree of protection as per IEC 60529		IP 68 per BWN Pr. 20	IP 68 per BWN Pr. 20	IP 68 per BWN Pr. 20	
Approvals		CE, cULus	CE, cULus	CE, cULus	
Material	Housing	Brass-coated	Stainless steel	Stainless steel	
	Sensing surface	PBT	PA 12	PA 12	
Connection		M12 connector, 4-pin	M12 connector, 4-pin	M12 connector, 4-pin	

Wiring diagrams, see page 958.

The meaning of switching distance markings can be found on page 962.

**Additional cable lengths and PUR cable jacket material available on request**

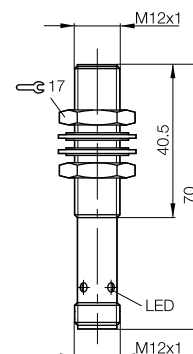
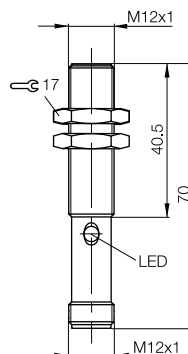
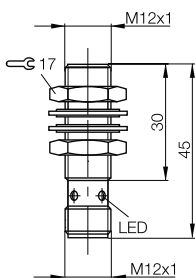

# DC 3-/4-wire Inductive Sensors Cylinder designs, M12x1

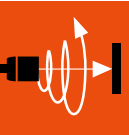

Inductive Sensors  
Global DC 3-wire  
DC 3-/4-wire  
Cylinder Designs  
Block Designs  
DC 2-wire  
AC/DC 2-wire  
AC 2-wire  
Special Properties  
Analog Distance measurement  
Accessories



<b>M12x1</b> Flush <b>2 mm</b> 0...1.6 mm ■	<b>M12x1</b> Flush <b>2 mm</b> 0...1.6 mm ■	<b>M12x1</b> Flush <b>2 mm</b> 0...1.6 mm ■	<b>M12x1</b> Flush <b>4 mm</b> 0...3.2 mm ■ ■	<b>M12x1</b> Flush <b>4 mm</b> 0...3.2 mm ■ ■
<b>BES00PH</b> BES 516-325-E4-C-S4-00,5	<b>BES00P8</b> BES 516-325-E4-C-02	<b>BES01AZ</b> BES 516-325-BO-C-02	<b>BES00PY</b> BES 516-325-G-E5-C-S4	<b>BES014W</b> BES M12EE-PSC40B-S04G
	<b>BES00YL</b> BES 516-370-E4-C-02	<b>BES01K2</b> BES 516-370-BO-C-02	<b>BES00Z0</b> BES 516-370-G-E5-C-S4	<b>BES014U</b> BES M12EE-POC40B-S04G
	<b>BES00T0</b> BES 516-329-E4-C-02	<b>BES01EF</b> BES 516-329-BO-C-02	<b>BES00TC</b> BES 516-329-G-E5-C-S4	
	<b>BES0108</b> BES 516-375-E4-C-02	<b>BES01L7</b> BES 516-375-BO-C-02	<b>BES010H</b> BES 516-375-G-E5-C-S4	
10...30 V DC 2 V 250 V AC (□) 200 mA Yes/Yes/Yes -25...+70 °C 5 kHz Yellow LED IP 68 per BWN Pr. 20 CE, cULus Brass-coated PBT 0.5 m PUR cable with M12 connector, 4-pin	10...30 V DC 2 V 250 V AC (□) 200 mA Yes/Yes/Yes -25...+70 °C 5 kHz Yellow LED IP 68 per BWN Pr. 20 CE, cULus Brass-coated PBT 2 m PVC cable, 3x0.34 mm <sup>2</sup>	10...30 V DC 1.5 V 250 V AC (□) 200 mA Yes/Yes/Yes -40...+85 °C 3 kHz Yellow LED IP 68 per BWN Pr. 20 CE, cULus Stainless steel PA 12 2 m PVC cable, 3x0.34 mm <sup>2</sup>	10...30 V DC 2.5 V 250 V AC (□) 200 mA Yes/Yes/Yes -25...+70 °C 2.5 kHz Yellow LED IP 68 per BWN Pr. 20 CE, cULus Brass-coated LCP M12 connector, 4-pin	10...30 V DC 2 V 250 V AC (□) 200 mA Yes/Yes/Yes -25...+85 °C 2 kHz Yellow LED IP 68 per BWN Pr. 20 CE, cULus Stainless steel LCP M12 connector, 4-pin

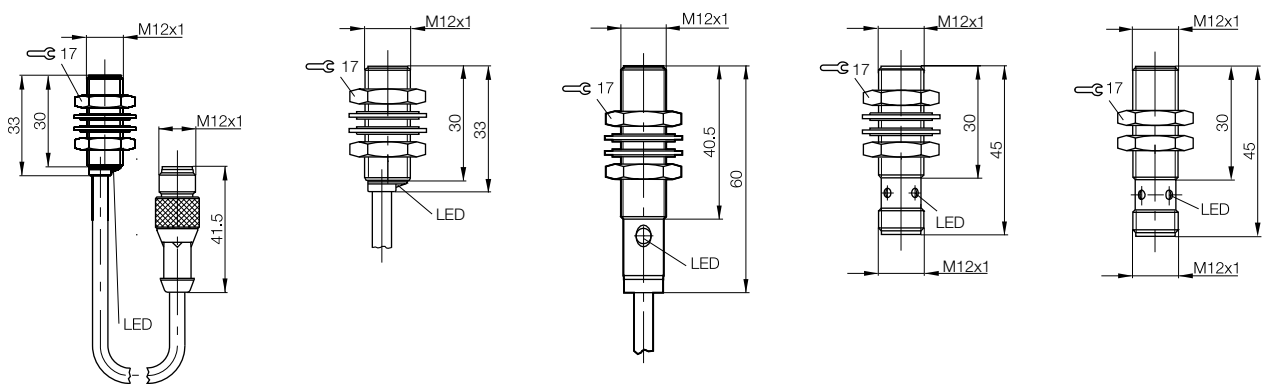

# DC 3-/4-wire Inductive Sensors

## Cylinder designs, M12x1



Model	<b>M12x1</b>	<b>M12x1</b>	<b>M12x1</b>	
Installation type (observe instructions in the Basic Information chapter)	Flush	Flush	Flush	
Rated switching distance $s_n$	<b>4 mm</b>	<b>4 mm</b>	<b>4 mm</b>	
Assured switching distance $s_a$	0...3 mm	0...3.2 mm	0...3.2 mm	
Switching distance marking	■ ■	■ ■	■ ■	
PNP, NO	<b>Ordering code</b>	<b>BES00PZ</b>	<b>BES02FU</b>	
	Part number	BES 516-325-G-E5-C-S49	BES M12EI-PSC40B-S04G	
PNP, NC	<b>Ordering code</b>	<b>BES00Z1</b>	<b>BES02FT</b>	
	Part number	BES 516-370-G-E5-C-S49	BES M12EI-POC40B-S04G	
NPN, NO	<b>Ordering code</b>	<b>BES03UP</b>	<b>BES00TE</b>	<b>BES02FR</b>
	Part number	BES 516-329-SA96-G-E5-C-S4	BES 516-329-G-E5-C-S49	BES M12EI-NSC40B-S04G
NPN, NC	<b>Ordering code</b>		<b>BES010J</b>	
	Part number		BES 516-375-G-E5-C-S49	
Supply voltage $U_s$	10...30 V DC	10...30 V DC	10...30 V DC	
Voltage drop $U_d$ at $I_o$ max.	2.5 V	2.5 V	2.5 V	
Rated insulation voltage $U_i$ (protection class)	250 V AC (□)	75 V DC	250 V AC (□)	
Rated operating current $I_o$	200 mA	200 mA	200 mA	
Polarity reversal protected/transposition protected/short-circuit protected	Yes/Yes/Yes	Yes/Yes/Yes	Yes/Yes/Yes	
Ambient temperature $T_a$	-25...+70 °C	-25...+70 °C	-25...+85 °C	
Switching frequency $f$ max.	2.5 kHz	2.5 kHz	1 kHz	
Output function indicator	Yellow LED	Yellow LED	Yellow LED	
Degree of protection as per IEC 60529	IP 68 per BWN Pr. 20	IP 67	IP 68 per BWN Pr. 20	
Approvals	CE, cULus	CE, cULus	CE, cULus	
Special properties				
Material	Housing	Brass-coated	Brass-coated	Stainless steel
	Sensing surface	With ceramic coating	LCP	LCP
Connection		M12 connector, 4-pin	M8 connector, 3-pin	M12 connector, 4-pin

Wiring diagrams, see page 958.  
The meaning of switching distance markings can be found on page 962.

**Additional cable lengths and PUR cable jacket material available on request**

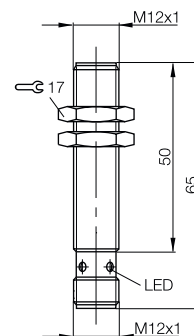
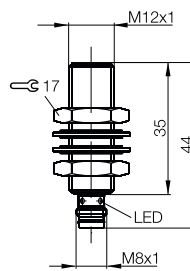
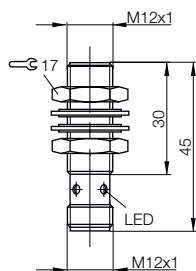



# DC 3-/4-wire Inductive Sensors Cylinder designs, M12x1



**SUPERSHORTIES**

M12x1	M12x1	M12x1	M12x1	M12x1
Flush	Flush	Flush	Flush	Flush
<b>4 mm</b>	<b>4 mm</b>	<b>4 mm</b>	<b>4 mm</b>	<b>4 mm</b>
0...3.2 mm	0...3.2 mm	0...3 mm	0...3.2 mm	0...3.2 mm
■ ■	■ ■	■ ■	■ ■	■ ■
<b>BES038C</b>	<b>BES01C7</b>	<b>BES035R</b>	<b>BES0464</b>	<b>BES00PW</b>
BES M12EI-PSC40B-S04G-009	BES 516-325-G-S4-C	BES 516-325-SA96-G-S4-C	BES M12EA-PSC40B-EP00,3-GS04	BES 516-325-G-E4-C-S4-00,5
			<b>BES0465</b>	
			BES M12EA-POC40B-EP00,3-GS04	
			<b>BES0467</b>	<b>BES03EK</b>
			BES M12EA-NSC40B-EP00,3-GS04	BES 516-329-G-E4-C-S4-PU-00,5
			<b>BES0466</b>	
			BES M12EA-NOC40B-EP00,3-GS04	
10...30 V DC	10...30 V DC	10...30 V DC	10...30 V DC	10...30 V DC
2.5 V	2.5 V	2.5 V	1.7 V	2.5 V
250 V AC (□)	250 V AC (□)	250 V AC (□)	75 V DC	250 V AC (□)
200 mA	200 mA	200 mA	100 mA	200 mA
Yes/Yes/Yes	Yes/Yes/Yes	Yes/Yes/Yes	Yes/Yes/Yes	Yes/Yes/Yes
-40...+85 °C	-25...+70 °C	-25...+70 °C	-40...+85 °C	-25...+70 °C
2 kHz	1 kHz	1 kHz	1 kHz	2.5 kHz
Yellow LED	Yellow LED	Yellow LED	Yellow LED	Yellow LED
IP 67	IP 68 per BWN Pr. 20	IP 68 per BWN Pr. 20	IP 67	IP 68 per BWN Pr. 20
CE, cULus	CE, cULus	CE, cULus	CE, cULus	CE, cULus
			<b>Short design</b>	
Stainless steel	Brass-coated	Brass-coated	Stainless steel	Brass-coated
LCP	LCP	With ceramic coating	LCP	LCP
M12 connector, 4-pin	M12 connector, 4-pin	M12 connector, 4-pin	0.3 m PUR cable with M12 connector, 4-pin	0.5 m PUR cable with M12 connector, 4-pin

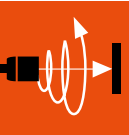

- Inductive Sensors
- Global DC 3-wire
- DC 3-/4-wire
- Cylinder Designs
- Block Designs
- DC 2-wire
- AC/DC 2-wire
- AC 2-wire
- Special Properties
- Analog Distance Measurement
- Accessories

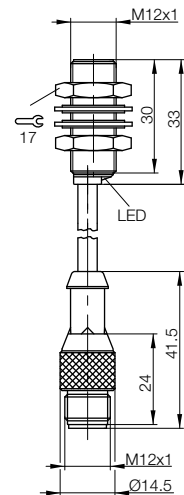
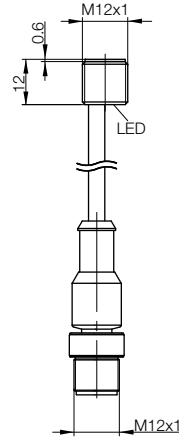
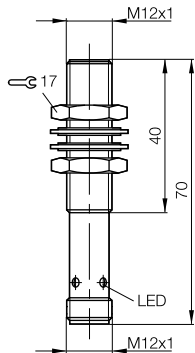
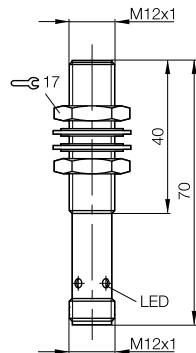
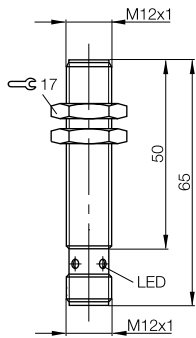

# DC 3-/4-wire Inductive Sensors

## Cylinder designs, M12x1



TRIPLEPROX

Model		<b>M12x1</b>	<b>M12x1</b>	<b>M12x1</b>	
Installation type (observe instructions in the Basic Information chapter)		Flush	Flush	Quasi-flush	
Rated switching distance $s_n$		<b>4 mm</b>	<b>4 mm</b>	<b>6 mm</b>	
Assured switching distance $s_a$		0...3.2 mm	0...3.2 mm	0...4.8 mm	
Switching distance marking		■ ■	■ ■	■ ■ ■	
PNP, NO	<b>Ordering code</b>	<b>BES00PL</b>	<b>BES00PP</b>	<b>BES02WZ</b>	
	Part number	BES 516-325-G-E4-C-02	BES 516-325-G-E4-C-PU-02	BES M12MG1-PSC60B-S04G	
PNP, NC	<b>Ordering code</b>	<b>BES00YU</b>	<b>BES00YW</b>	<b>BES02WY</b>	
	Part number	BES 516-370-G-E4-C-02	BES 516-370-G-E4-C-PU-02	BES M12MG1-POC60B-S04G	
PNP, complementary	<b>Ordering code</b>				
	Part number				
NPN, NO	<b>Ordering code</b>	<b>BES00T6</b>	<b>BES00T9</b>	<b>BES02WW</b>	
	Part number	BES 516-329-G-E4-C-02	BES 516-329-G-E4-C-PU-02	BES M12MG1-NSC60B-S04G	
NPN, NC	<b>Ordering code</b>	<b>BES010C</b>	<b>BES010E</b>	<b>BES02WU</b>	
	Part number	BES 516-375-G-E4-C-02	BES 516-375-G-E4-C-PU-02	BES M12MG1-NOC60B-S04G	
Supply voltage $U_s$		10...30 V DC	10...30 V DC	10...30 V DC	
Voltage drop $U_d$ at $I_o$ max.		2.5 V	2.5 V	2 V	
Rated insulation voltage $U_i$ (protection class)		250 V AC (□)	250 V AC (□)	75 V DC	
Rated operating current $I_o$		200 mA	200 mA	200 mA	
Polarity reversal protected/transposition protected/short-circuit protected		Yes/Yes/Yes	Yes/Yes/Yes	Yes/Yes/Yes	
Ambient temperature $T_a$		-25...+70 °C	-25...+70 °C	-25...+70 °C	
Switching frequency $f$ max.		2.5 kHz	2.5 kHz	800 Hz	
Output function indicator		Yellow LED	Yellow LED	Yellow LED	
Degree of protection as per IEC 60529		IP 68 per BWN Pr. 20	IP 68 per BWN Pr. 20	IP 67	
Approvals		CE, cULus	CE, cULus	CE	
Special properties				<b>Large switching distance</b>	
Material	Housing	Brass-coated	Brass-coated	Brass-coated	
	Sensing surface	LCP	LCP	PBT	
Connection		2 m PVC cable, 3x0.34 mm <sup>2</sup>	2 m PUR cable, 3x0.34 mm <sup>2</sup>	M12 connector, 4-pin	

Wiring diagrams, see page 958.  
The meaning of switching distance markings can be found on page 962.

**Additional cable lengths and PUR cable jacket material available on request**

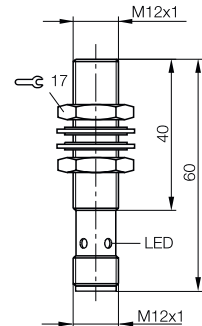
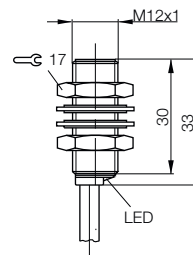
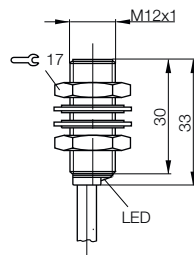



**HYPERPROX**

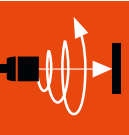

Inductive Sensors

Global DC 3-wire

DC 3-/4-wire

Cylinder Designs

Block Designs

DC 2-wire

AC/DC 2-wire

AC 2-wire

Special Properties

Analog Distance Measurement

Accessories

M12x1	M12x1	M12x1	M12x1	M12x1
Quasi-flush	Not flush	Not flush	Not flush	Not flush
<b>8 mm</b>	<b>4 mm</b>	<b>4 mm</b>	<b>4 mm</b>	<b>4 mm</b>
0...5.8 mm	0...3.2 mm	0...3.2 mm	0...3.2 mm	0...3.2 mm
■■■■	■	■	■	■
<b>BES01ZN</b>	<b>BES00UY</b>		<b>BES02FC</b>	<b>BES01H6</b>
BES M12MI-PSH80B-S04G	BES 516-356-E5-C-S4		BES 515-356-S4-C	BES 516-356-S4-C
	<b>BES00KM</b>		<b>BES018Y</b>	
	BES 516-3019-E5-C-S4		BES 516-3019-S4-C	
				<b>BES0178</b>
				BES 516-131-S4-C
<b>BES01ZY</b>		<b>BES030Z</b>	<b>BES01HE</b>	
BES M12MI-NSH80B-S04G		BES 516-357-E5-Y-S4	BES 516-357-S4-C	
			<b>BES019E</b>	
			BES 516-3030-S4-C	
10...55 V DC	10...30 V DC	10...30 V DC	10...30 V DC	10...30 V DC
2.5 V	2 V	3.5 V	1.5 V	1.5 V
250 V AC (□)	250 V AC (□)	75 V DC	250 AC (□)	250 V AC (□)
200 mA	200 mA	130 mA	200 mA	200 mA
Yes/Yes/Yes	Yes/Yes/Yes	Yes/Yes/Yes	Yes/Yes/Yes	Yes/Yes/Yes
0...+60 °C	-25...+70 °C	-25...+70 °C	-40...+85 °C	-40...+85 °C
300 Hz	2 kHz	400 Hz	1.5 kHz	1.5 kHz
Yellow LED	Yellow LED	Yellow LED	Yellow LED	Yellow LED
IP 67	IP 68 per BWN Pr. 20	IP 68 per BWN Pr. 20	IP 68 per BWN Pr. 20	IP 68 per BWN Pr. 20
CE	CE, cULus	CE, cULus	CE, cULus	CE, cULus
<b>Large switching distance</b>				
Brass-coated	Brass-coated	Brass-coated	Stainless steel	Stainless steel
LCP	PBT	PA 12	PA 12	PA 12
M12 connector, 4-pin	M12 connector, 4-pin	M12 connector, 4-pin	M12 connector, 4-pin	M12 connector, 4-pin

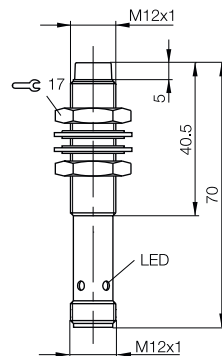
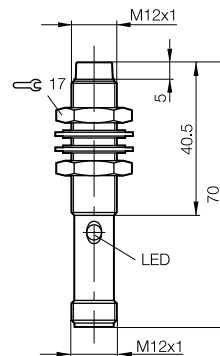
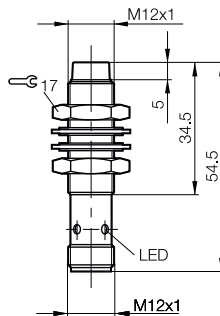
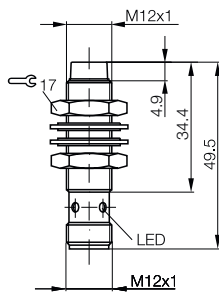
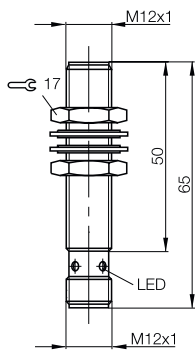

# DC 3-/4-wire Inductive Sensors

## Cylinder designs, M12x1



Model		<b>M12x1</b>	<b>M12x1</b>	<b>M12x1</b>
Installation type (observe instructions in the Basic Information chapter)		Not flush	Not flush	Not flush
Rated switching distance $s_n$		<b>4 mm</b>	<b>4 mm</b>	<b>4 mm</b>
Assured switching distance $s_a$		0...3.2 mm	0...3.2 mm	0...3.2 mm
Switching distance marking		■	■	■
PNP, NO	<b>Ordering code</b>	<b>BES00UT</b>	<b>BES00UL</b>	<b>BES01H1</b>
	Part number	BES 516-356-E4-C-S4-00,3	BES 516-356-E4-C-02	BES 516-356-BO-C-02
PNP, NC	<b>Ordering code</b>			<b>BES018P</b>
	Part number			BES 516-3019-BO-C-02
NPN, NO	<b>Ordering code</b>		<b>BES00W0</b>	<b>BES01H7</b>
	Part number		BES 516-357-E4-C-02	BES 516-357-BO-C-02
NPN, NC	<b>Ordering code</b>		<b>BES00M0</b>	<b>BES019A</b>
	Part number		BES 516-3030-E4-C-02	BES 516-3030-BO-C-02
Supply voltage $U_s$		10...30 V DC	10...30 V DC	10...30 V DC
Voltage drop $U_d$ at $I_o$ max.		2 V	2 V	1.5 V
Rated insulation voltage $U_i$ (protection class)		250 V AC (□)	250 V AC (□)	250 V AC (□)
Rated operating current $I_o$		200 mA	200 mA	200 mA
Polarity reversal protected/transposition protected/short-circuit protected		Yes/Yes/Yes	Yes/Yes/Yes	Yes/Yes/Yes
Ambient temperature $T_a$		-25...+70 °C	-25...+70 °C	-40...+85 °C
Switching frequency $f$ max.		2 kHz	2 kHz	1.2 kHz
Output function indicator		Yellow LED	Yellow LED	Yellow LED
Degree of protection as per IEC 60529		IP 68 per BWN Pr. 20	IP 68 per BWN Pr. 20	IP 68 per BWN Pr. 20
Approvals		CE, cULus	CE, cULus	CE, cULus
Special properties				
Material	Housing	Brass-coated	Brass-coated	Stainless steel
	Sensing surface	PBT	PBT	PA 12
Connection		0.3 m PUR cable with M12 connector, 4-pin	2 m PVC cable, 3x0.34 mm <sup>2</sup>	2 m PVC cable, 3x0.34 mm <sup>2</sup>

Wiring diagrams, see page 958.  
The meaning of switching distance markings can be found on page 962.

**Additional cable lengths and PUR cable jacket material available on request**

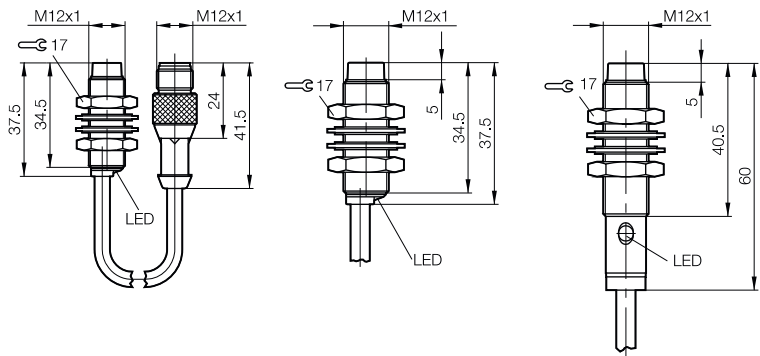



SUPERSHORTIES		TRIPLEPROX	
<b>M12x1</b> Not flush <b>6 mm</b> 0...4.8 mm ■ ■	<b>M12x1</b> Not flush <b>8 mm</b> 0...6.4 mm ■ ■	<b>M12x1</b> Not flush <b>10 mm</b> 0...8 mm ■ ■ ■	<b>M12x1</b> Not flush <b>10 mm</b> 0...8 mm ■ ■ ■
<b>BES047L</b> BES M12EA-PSC60F-EP00,3-GS04	<b>BES01PN</b> BES M12EG-PSC80F-S04G	<b>BES02WK</b> BES M12MC1-PSC10F-S04G	<b>BES02WR</b> BES M12MF1-PSC10F-S04G
<b>BES047M</b> BES M12EA-POC60F-EP00,3-GS04			<b>BES02WP</b> BES M12MF1-POC10F-S04G
<b>BES047P</b> BES M12EA-NSC60F-EP00,3-GS04		<b>BES02WJ</b> BES M12MC1-NSC10F-S04G	<b>BES02WN</b> BES M12MF1-NSC10F-S04G
<b>BES047N</b> BES M12EA-NOC60F-EP00,3-GS04			
10...30 V DC 2.5 V 75 V DC 100 mA Yes/Yes/Yes -40...+85 °C 1 kHz Yellow LED IP 67 CE, cULus <b>Short design</b> Stainless steel LCP 0.3 m PUR cable with M12 connector, 4-pin	10...30 V DC 2.5 V 250 V AC (□) 200 mA Yes/Yes/Yes -25...+70 °C 1.5 kHz Yellow LED IP 68 per BWN Pr. 20 CE, cULus	10...30 V DC 2 V 75 V DC 200 mA Yes/Yes/Yes -25...+70 °C 400 Hz Yellow LED IP 67 CE <b>Large switching distance</b> Brass-coated PBT M12 connector, 4-pin	10...30 V DC 2 V 75 V DC 200 mA Yes/Yes/Yes -25...+70 °C 400 Hz Yellow LED IP 67 CE <b>Large switching distance</b> Brass-coated PBT M12 connector, 4-pin

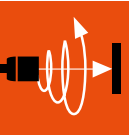

- Inductive Sensors
- Global DC 3-wire
- DC 3-/4-wire
- Cylinder Designs
- Block Designs
- DC 2-wire
- AC/DC 2-wire
- AC 2-wire
- Special Properties
- Analog Distance Measurement
- Accessories

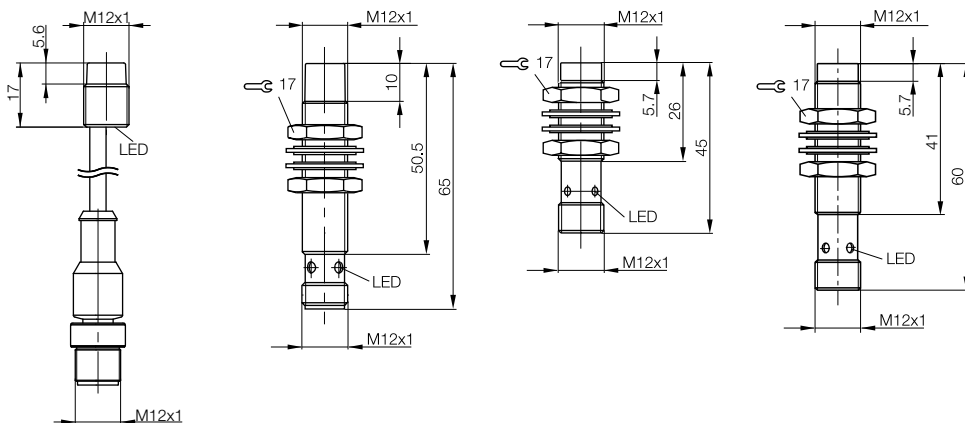

# DC 3-/4-wire Inductive Sensors

## Cylinder designs, M18x1



Model		<b>M18x1</b>	<b>M18x1</b>	<b>M18x1</b>
Installation type (observe instructions in the Basic Information chapter)		Flush	Flush	Flush
Rated switching distance $s_n$		<b>5 mm</b>	<b>5 mm</b>	<b>5 mm</b>
Assured switching distance $s_a$		0...4 mm	0...4 mm	0...4 mm
Switching distance marking		■	■	■
PNP, NO	<b>Ordering code</b>	<b>BES00R6</b>		<b>BES02ET</b>
	Part number	BES 516-326-E5-C-S4		BES 515-326-E5-T-S4
PNP, NC	<b>Ordering code</b>		<b>BES00YC</b>	
	Part number		BES 516-367-E5-Y-S4	
PNP, complementary	<b>Ordering code</b>			
	Part number			
NPN, NO	<b>Ordering code</b>		<b>BES00UC</b>	
	Part number		BES 516-355-E5-Y-S4	
NPN, NC	<b>Ordering code</b>			
	Part number			
NPN, complementary	<b>Ordering code</b>			
	Part number			
Supply voltage $U_S$		10...30 V DC	10...30 V DC	10...30 V DC
Voltage drop $U_d$ at $I_e$ max.		2 V	3.5 V	3.5 V
Rated insulation voltage $U_i$ (protection class)		75 V DC	75 V DC	75 V DC
Rated operating current $I_e$		200 mA	130 mA	130 mA
Polarity reversal protected/transposition protected/short-circuit protected		Yes/Yes/Yes	Yes/Yes/Yes	Yes/Yes/Yes
Ambient temperature $T_a$		-25...+70 °C	-25...+70 °C	-40...+105 °C*
Switching frequency $f$ max.		1 kHz	500 Hz	500 Hz
Output function indicator		Yellow LED	Yellow LED	No
Degree of protection as per IEC 60529		IP 67	IP 67	IP 69K, IP 68 as per BWN Pr. 27
Approvals		CE, cULus	CE, cULus	CE, cULus
Special properties				<b>Resistant to high-pressure cleaners</b>
Material	Housing	Brass-coated	Brass-coated	Stainless steel
	Sensing surface	PBT	PA 12	PA 12
Connection		M12 connector, 4-pin	M12 connector, 4-pin	M12 connector, 4-pin

Wiring diagrams, see page 958.  
The meaning of switching distance markings can be found on page 962.

**Additional cable lengths and PUR cable jacket material available on request**

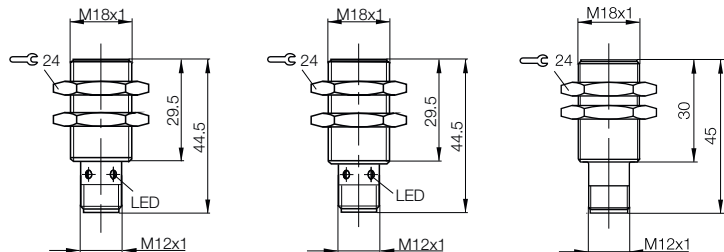

**\*max. load current over temperature**

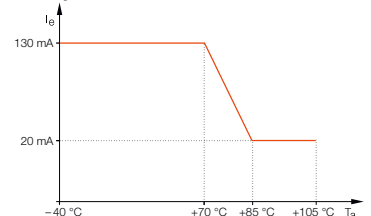

# DC 3-/4-wire Inductive Sensors Cylinder designs, M18x1

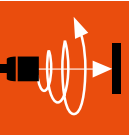

Inductive Sensors  
Global DC 3-wire  
DC 3-/4-wire  
Cylinder Designs  
Block Designs  
DC 2-wire  
AC/DC 2-wire  
AC 2-wire  
Special Properties  
Analog Distance Measurement  
Accessories

M18x1	M18x1	M18x1	M18x1	M18x1
Flush	Flush	Flush	Flush	Flush
<b>5 mm</b>	<b>5 mm</b>	<b>5 mm</b>	<b>5 mm</b>	<b>5 mm</b>
0...4 mm	0...4 mm	0...4 mm	0...4 mm	0...4 mm
■	■	■	■	■
<b>BES01CW</b>	<b>BES01CZ</b>	<b>BES02EU</b>	<b>BES00R5</b>	<b>BES00R0</b>
BES 516-326-S4-C	BES 516-326-S4-H	BES 515-326-S4-C	BES 516-326-E4-C-S4-00,2	BES 516-326-E4-C-02
<b>BES01JW</b>				
BES 516-367-S4-C				
<b>BES015N</b>				
BES 516-105-S4-C				
<b>BES01H0</b>				
BES 516-355-S4-C				
<b>BES01JU</b>				
BES 516-366-S4-C				
<b>BES015U</b>				
BES 516-111-S4-C				
10...30 V DC	10...55 V DC	10...30 V DC	10...30 V DC	10...30 V DC
2.5 V	1.5 V	1.5 V	2 V	2 V
250 V AC (□)	250 V AC (□)	250 V AC (□)	75 V DC	75 V DC
200 mA	200 mA	200 mA	200 mA	200 mA
Yes/Yes/Yes	Yes/Yes/Yes	Yes/Yes/Yes	Yes/Yes/Yes	Yes/Yes/Yes
-25...+70 °C	-25...+70 °C	-40...+85 °C	-25...+70 °C	-25...+70 °C
900 Hz	900 Hz	900 Hz	1 kHz	1 kHz
Yellow LED	Yellow LED	Yellow LED	Yellow LED	Yellow LED
IP 68 per BWN Pr. 20	IP 68 per BWN Pr. 20	IP 68 per BWN Pr. 20	IP 67	IP 67
CE, cULus	CE	CE, cULus	CE, cULus	CE, cULus
Brass-coated	Brass-coated	Stainless steel	Brass-coated	Brass-coated
PA 12	PA 12	PA 12	PA 12	PBT
M12 connector, 4-pin	M12 connector, 4-pin	M12 connector, 4-pin	0.2 m PUR cable with M12 connector, 4-pin	2 m PVC cable, 3x0.34 mm <sup>2</sup>

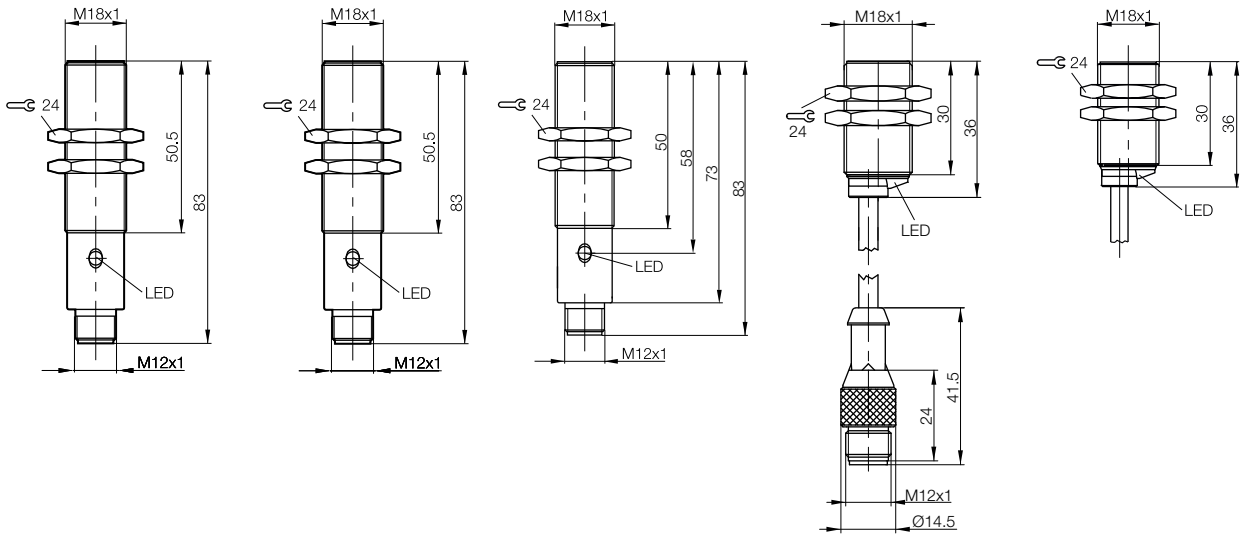

# DC 3-/4-wire Inductive Sensors

## Cylinder designs, M18x1



Model		<b>M18x1</b>	<b>M18x1</b>	<b>M18x1</b>
Installation type (observe instructions in the Basic Information chapter)		Flush	Flush	Flush
Rated switching distance $s_n$		<b>5 mm</b>	<b>8 mm</b>	<b>8 mm</b>
Assured switching distance $s_a$		0...4 mm	0...6.4 mm	0...6.4 mm
Switching distance marking		■	■■	■■■
PNP, NO	<b>Ordering code</b>	<b>BES01CE</b>	<b>BES030R</b>	<b>BES00RC</b>
	Part number	BES 516-326-BO-C-02	BES 516-326-G-E5-Y-S49	BES 516-326-G-E5-C-S4
PNP, NC	<b>Ordering code</b>		<b>BES00YK</b>	<b>BES00YJ</b>
	Part number		BES 516-367-G-E5-Y-S49	BES 516-367-G-E5-Y-S4
PNP, complementary	<b>Ordering code</b>			
	Part number			
NPN, NO	<b>Ordering code</b>	<b>BES01JP</b>	<b>BES00UK</b>	<b>BES00UJ</b>
	Part number	BES 516-366-BO-C-02	BES 516-355-G-E5-Y-S49	BES 516-355-G-E5-Y-S4
NPN, NC	<b>Ordering code</b>			
	Part number			
Supply voltage $U_s$		10...30 V DC	10...30 V DC	10...30 V DC
Voltage drop $U_d$ at $I_o$ max.		2.5 V	3.5 V	3.5 V
Rated insulation voltage $U_i$ (protection class)		250 V AC (□)	75 V DC	75 V DC
Rated operating current $I_o$		200 mA	130 mA	130 mA
Polarity reversal protected/transposition protected/short-circuit protected		Yes/Yes/Yes	Yes/Yes/Yes	Yes/Yes/Yes
Ambient temperature $T_a$		-25...+70 °C	-25...+70 °C	-25...+70 °C
Switching frequency $f$ max.		500 Hz	200 Hz	200 Hz
Output function indicator		Yellow LED	Yellow LED	Yellow LED
Degree of protection as per IEC 60529		IP 68 per BWN Pr. 20	IP 67	IP 67
Approvals		CE, cULus	CE, cULus	CE, cULus
Material	Housing	Brass-coated	Brass-coated	Brass-coated
	Sensing surface	PA 12	PBT	PBT
Connection		2 m PVC cable, 3x0.34 mm <sup>2</sup>	M8 connector, 3-pin	M12 connector, 4-pin

Wiring diagrams, see page 958.  
The meaning of switching distance markings can be found on page 962.

**Additional cable lengths and PUR cable jacket material available on request**

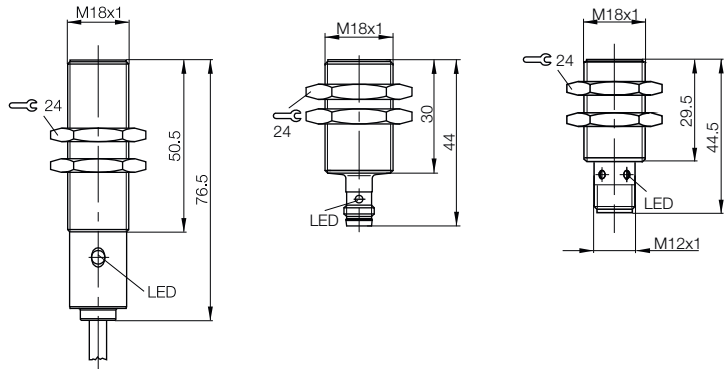



# DC 3-/4-wire Inductive Sensors Cylinder designs, M18x1



M18x1	M18x1	M18x1	M18x1	M18x1
Flush	Flush	Flush	Flush	Flush
<b>8 mm</b>	<b>8 mm</b>	<b>8 mm</b>	<b>8 mm</b>	<b>8 mm</b>
0...6.3 mm	0...6.4 mm	0...6.4 mm	0...6.4 mm	0...6.4 mm
■ ■	■ ■	■ ■	■ ■	■ ■
<b>BES02P3</b>	<b>BES02H0</b>	<b>BES01CT</b>	<b>BES01CU</b>	<b>BES00RA</b>
BES 516-326-SA96-G-E5-Y-S4	BES M18EI-PSC80B-S04G	BES 516-326-G-S4-C	BES 516-326-G-S4-H	BES 516-326-G-E4-C-S4-00,3
	<b>BES02FZ</b>			
	BES M18EI-POC80B-S04G			
			<b>BES015M</b>	
			BES 516-105-G-S4-H	
<b>BES02P4</b>	<b>BES02FY</b>			
BES 516-355-SA96-G-E5-Y-S4	BES M18EI-NSC80B-S04G			
	<b>BES02FW</b>			
	BES M18EI-NOC80B-S04G			
10...30 V DC	10...30 V DC	10...30 V DC	10...55 V DC	10...30 V DC
3.5 V	2.5 V	2.5 V	2.5 V	2.5 V
75 V DC	250 V AC (□)	75 V DC (□)	75 V DC	75 V DC
130 mA	200 mA	200 mA	200 mA	200 mA
Yes/Yes/Yes	Yes/Yes/Yes	Yes/Yes/Yes	Yes/Yes/Yes	Yes/Yes/Yes
-25...+70 °C	-40...+85 °C	0...70 °C	0...+70 °C	-25...+70 °C
200 Hz	700 Hz	80 Hz	80 Hz	500 Hz
Yellow LED	Yellow LED	Yes	Yellow LED	Yellow LED
IP 67	IP 68 per BWN Pr. 20	IP 67	IP 67	IP 67
CE, cULus	CE, cULus	CE, cULus	CE	CE, cULus
Brass-coated	Stainless steel	Brass-coated	Brass-coated	Brass-coated
With ceramic coating	PBT	PBT	PBT	PBT
M12 connector, 4-pin	M12 connector, 4-pin	M12 connector, 4-pin	M12 connector, 4-pin	0.3 m PUR cable with M12 connector, 4-pin

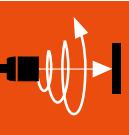

Inductive Sensors  
Global DC 3-wire  
DC 3-/4-wire  
Cylinder Designs  
Block Designs  
DC 2-wire  
AC/DC 2-wire  
AC 2-wire  
Special Properties  
Analog Distance Measurement  
Accessories

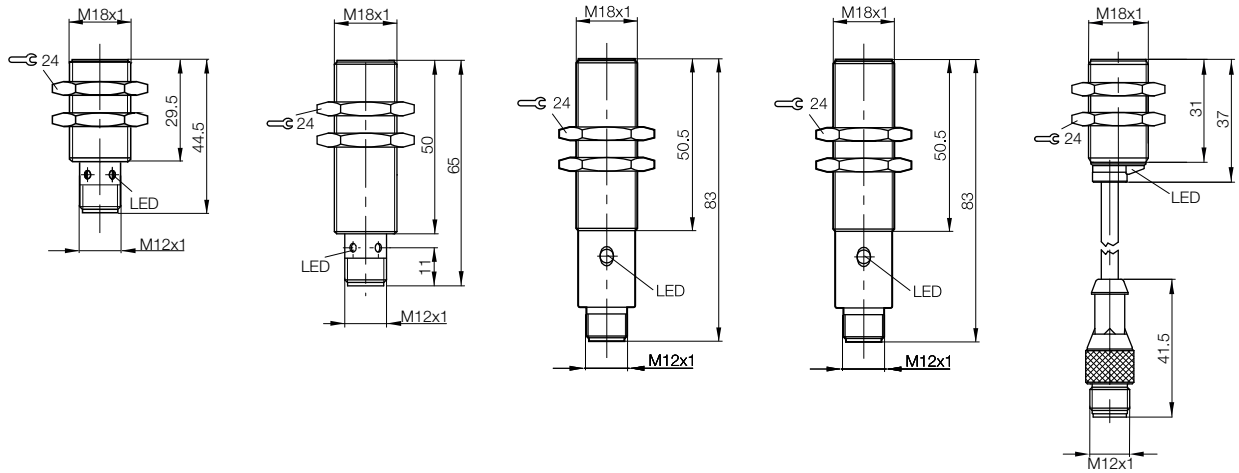

# DC 3-/4-wire Inductive Sensors

## Cylinder designs, M18x1



TRIPLEPROX

TRIPLEPROX

Model		<b>M18x1</b>	<b>M18x1</b>	<b>M18x1</b>
Installation type (observe instructions in the Basic Information chapter)		Flush	Quasi-flush	Quasi-flush
Rated switching distance $s_n$		<b>8 mm</b>	<b>12 mm</b>	<b>12 mm</b>
Assured switching distance $s_a$		0...6.4 mm	0...9.6 mm	0...9.6 mm
Switching distance marking		■ ■	■ ■ ■	■ ■ ■
PNP, NO	<b>Ordering code</b>	<b>BES01CN</b>	<b>BES02Y5</b>	<b>BES02Y9</b>
	Part number	BES 516-326-G-BO-C-PU-02	BES M18MD1-PSC12B-S04G	BES M18MG1-PSC12B-S04G
PNP, normally closed	<b>Ordering code</b>			
	Part number			
NPN, NO	<b>Ordering code</b>		<b>BES02Y4</b>	<b>BES02Y8</b>
	Part number		BES M18MD1-NSC12B-S04G	BES M18MG1-NSC12B-S04G
Supply voltage $U_s$		10...30 V DC	10...30 V DC	10...30 V DC
Voltage drop $U_d$ at $I_e$ max.		2.5 V	2 V	2 V
Rated insulation voltage $U_i$ (protection class)		250 V AC (II)	75 V DC	75 V DC
Rated operating current $I_e$		200 mA	200 mA	200 mA
Polarity reversal protected/transposition protected/short-circuit protected		Yes/Yes/Yes	Yes/Yes/Yes	Yes/Yes/Yes
Ambient temperature $T_a$		0...+70 °C	-25...+70 °C	-25...+70 °C
Switching frequency $f$ max.		80 Hz	500 Hz	500 Hz
Output function indicator		Yellow LED	Yellow LED	Yellow LED
Degree of protection as per IEC 60529		IP 67	IP 67	IP 67
Approvals		CE, cULus	CE	CE
Special properties			<b>Large switching distance</b>	<b>Large switching distance</b>
Material	Housing	Brass-coated	Brass-coated	Brass-coated
	Sensing surface	PA 12	PBT	PBT
Connection		2 m PUR cable, 3x0.34 mm <sup>2</sup>	M12 connector, 4-pin	M12 connector, 4-pin

Wiring diagrams, see page 958.  
The meaning of switching distance markings can be found on page 962.

**Additional cable lengths and PUR cable jacket material available on request**

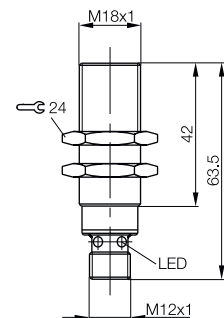
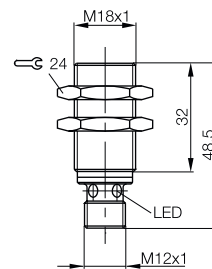
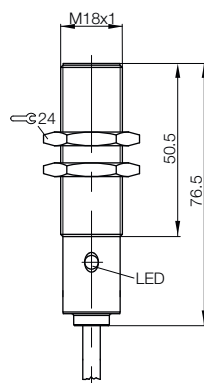



M18x1	M18x1	M18x1	M18x1	M18x1
Not flush	Not flush	Not flush	Not flush	Not flush
<b>8 mm</b>	<b>8 mm</b>	<b>8 mm</b>	<b>8 mm</b>	<b>8 mm</b>
0...6.5 mm	0...6.5 mm	0...6.5 mm	0...6.5 mm	0...6.5 mm
■	■	■	■	■
<b>BES00WM</b>	<b>BES02FK</b>	<b>BES02FM</b>	<b>BES03AW</b>	<b>BES01HY</b>
BES 516-360-E5-Y-S4	BES 515-360-E5-T-S4	BES 515-360-SA12-S4-T	BES 516-360-S4-L	BES 516-360-S4-C
<b>BES00LL</b>				<b>BES0193</b>
BES 516-3026-E5-Y-S4				BES 516-3026-S4-C
<b>BES00WT</b>				
BES 516-361-E5-Y-S4				
10...30 V DC	10...30 V DC	10...30 V DC	10...30 V DC	10...30 V DC
3.5 V	3.5 V	3.5 V	2.5 V	1.5 V
75 V DC	75 DC	75 V DC	250 V AC (□)	250 V AC (□)
130 mA	130 mA	130 mA	400 mA	200 mA
Yes/Yes/Yes	Yes/Yes/Yes	Yes/Yes/Yes	Yes/No/No	Yes/Yes/Yes
-25...+70 °C	-40...+105 °C*	-40...+85 °C (momentarily 105 °C)	-40...+85 °C	-25...+70 °C
200 Hz	200 Hz	200 Hz	200 Hz	600 Hz
Yellow LED	No	No	Yellow LED	Yellow LED
IP 67	IP 69K, IP 68 as per BWN Pr. 27	IP 69K, IP 68 as per BWN Pr. 27	IP 68 per BWN Pr. 20	IP 68 per BWN Pr. 20
CE, cULus	CE, cULus	CE, cULus	CE, cULus	CE, cULus
	<b>Resistant to high-pressure cleaners</b>	<b>Resistant to high-pressure cleaners</b>		
Brass-coated	Stainless steel	Stainless steel	Brass-coated	Brass-coated
PA 12	PA 12	PA 12	PA 12	PA 12
M12 connector, 4-pin	M12 connector, 4-pin	M12 connector, 4-pin	M12 connector, 4-pin	M12 connector, 4-pin

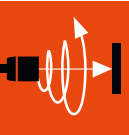

Inductive Sensors  
Global DC 3-wire  
DC 3-/4-wire  
Cylinder Designs  
Block Designs  
DC 2-wire  
AC/DC 2-wire  
AC 2-wire  
Special Properties  
Analog Distance Measurement  
Accessories

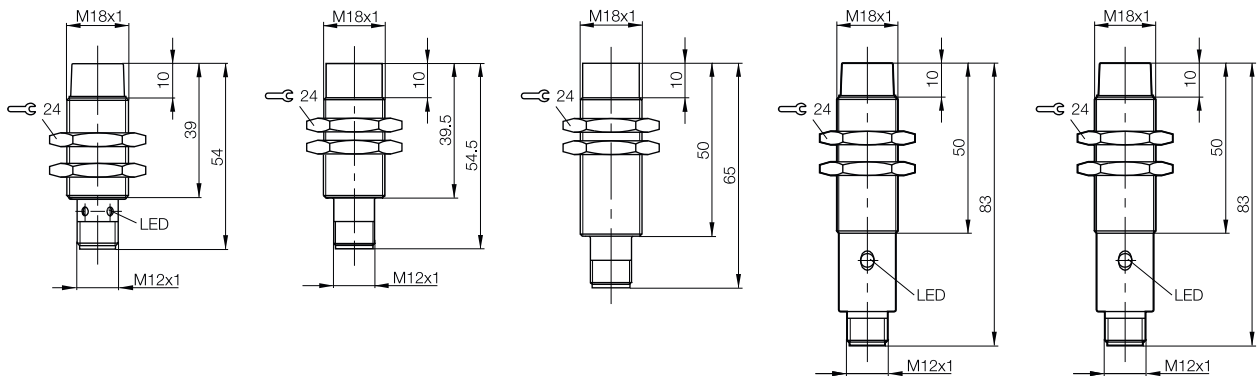

\*max. load current over temperature

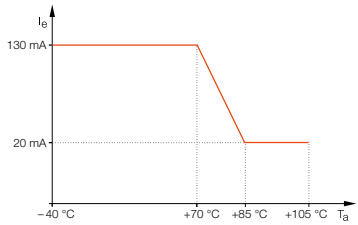

**Recommended short-circuit protection device:** Miniature fuse in accordance with IEC 60127-2 Sheet 1, ≤ 2 A (fast-acting). The fuse has to be in the load current line; the fuse may not be placed in the output line.

# DC 3-/4-wire Inductive Sensors

## Cylinder designs, M18x1



Model		<b>M18x1</b>	<b>M18x1</b>	<b>M18x1</b>
Installation type (observe instructions in the Basic Information chapter)		Not flush	Not flush	Not flush
Rated switching distance $s_n$		<b>8 mm</b>	<b>8 mm</b>	<b>8 mm</b>
Assured switching distance $s_a$		0...6.5 mm	0...6.5 mm	0...6.5 mm
Switching distance marking		■	■	■
PNP, NO	<b>Ordering code</b>			<b>BES02FL</b>
	Part number			BES 516-360-S4-C
PNP, normally closed	<b>Ordering code</b>			
	Part number			
PNP, complementary	<b>Ordering code</b>	<b>BES016Y</b>		
	Part number	BES 516-123-S4-C		
NPN, NO	<b>Ordering code</b>		<b>BES01J5</b>	
	Part number		BES 516-361-S4-C	
NPN, NC	<b>Ordering code</b>		<b>BES019H</b>	
	Part number		BES 516-3031-S4-C	
NPN, complementary	<b>Ordering code</b>		<b>BES0171</b>	
	Part number		BES 516-124-S4-C	
Supply voltage $U_S$		10...30 V DC	10...30 V DC	10...30 V DC
Voltage drop $U_d$ at $I_e$ max.		2.5 V	2.5 V	1.5 V
Rated insulation voltage $U_i$ (protection class)		250 V AC (□)	250 V AC (□)	250 V AC (□)
Rated operating current $I_e$		200 mA	200 mA	200 mA
Polarity reversal protected/transposition protected/short-circuit protected		Yes/Yes/Yes	Yes/Yes/Yes	Yes/Yes/Yes
Ambient temperature $T_a$		-40...+85 °C	-25...+70 °C	-40...+85 °C
Switching frequency $f$ max.		200 Hz	200 Hz	600 Hz
Output function indicator		Yellow LED	Yellow LED	Yellow LED
Degree of protection as per IEC 60529		IP 68 per BWN Pr. 20	IP 68 per BWN Pr. 20	IP 68 per BWN Pr. 20
Approvals		CE, cULus	CE, cULus	CE, cULus
Material	Housing	Brass-coated	Brass-coated	Stainless steel
	Sensing surface	PA 12	PA 12	PA 12
Connection		M12 connector, 4-pin	M12 connector, 4-pin	M12 connector, 4-pin

Wiring diagrams, see page 958.  
The meaning of switching distance markings can be found on page 962.

**Additional cable lengths and PUR cable jacket material available on request**

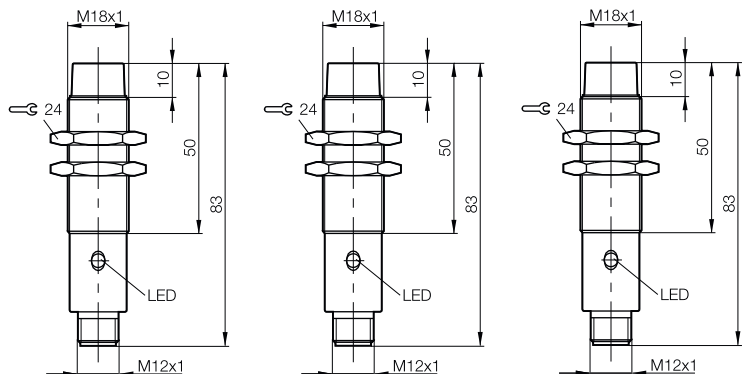

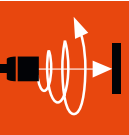

Inductive Sensors

Global DC 3-wire

DC 3-/4-wire

Cylinder Designs

Block Designs

DC 2-wire

AC/DC 2-wire

AC 2-wire

Special Properties

Analog Distance Measurement

Accessories

<b>M18x1</b> Not flush <b>8 mm</b> 0...6.5 mm ■	<b>M18x1</b> Not flush <b>8 mm</b> 0...6.5 mm ■	<b>M18x1</b> Not flush <b>8 mm</b> 0...6.5 mm ■	<b>M18x1</b> Not flush <b>8 mm</b> 0...6.5 mm ■	
	<b>BES00WH</b> BES 516-360-E4-Y-02			
	<b>BES00LH</b> BES 516-3026-E4-Y-02		<b>BES018Z</b> BES 516-3026-BO-C-02	
<b>BES02E1</b> BES 515-123-S4-C				
	<b>BES00WN</b> BES 516-361-E4-Y-02	<b>BES01HZ</b> BES 516-361-BO-C-02		
		<b>BES019F</b> BES 516-3031-BO-C-02		
10...30 V DC 2.5 V 250 V AC (□) 200 mA Yes/Yes/Yes -40...+85 °C 200 Hz Yellow LED IP 68 per BWN Pr. 20 CE, cULus Stainless steel PA 12 M12 connector, 4-pin	10...30 V DC 3.5 V 250 V AC (□) 130 mA Yes/Yes/Yes -25...+70 °C 200 Hz Yellow LED IP 68 per BWN Pr. 20 CE, cULus Brass-coated PA 12 2 m PVC cable, 3x0.34 mm <sup>2</sup>	10...30 V DC 2.5 V 250 V AC (□) 200 mA Yes/Yes/Yes -25...+70 °C 200 Hz Yellow LED IP 67 CE, cULus Brass-coated PA 12 2 m PVC cable, 3x0.34 mm <sup>2</sup>	10...30 V DC 1.5 V 250 V AC (□) 200 mA Yes/Yes/Yes -25...+70 °C 600 Hz Yellow LED IP 68 per BWN Pr. 20 CE, cULus Brass-coated PA 12 2 m PVC cable, 3x0.34 mm <sup>2</sup>	

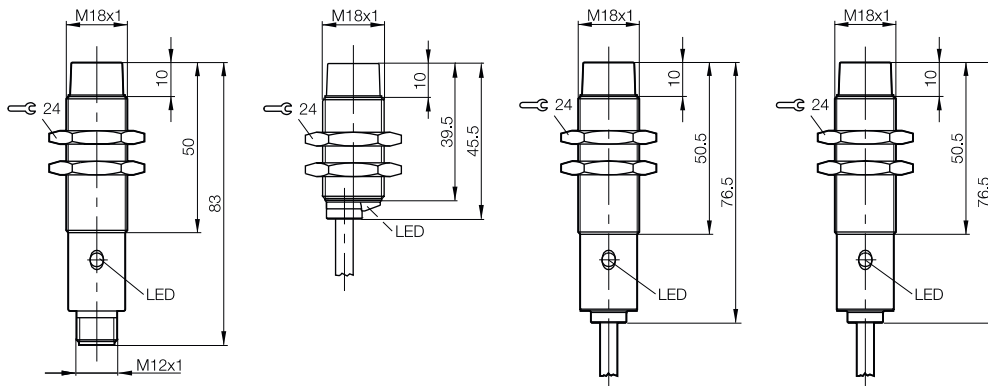

# DC 3-/4-wire Inductive Sensors

## Cylinder designs, M18x1



TRIPLEPROX

Model		<b>M18x1</b>	<b>M18x1</b>
Installation type (observe instructions in the Basic Information chapter)		Not flush	Not flush
Rated switching distance $s_n$		<b>16 mm</b>	<b>20 mm</b>
Assured switching distance $s_a$		0...13 mm	0...16 mm
Switching distance marking		■ ■	■ ■ ■
PNP, NO	<b>Ordering code</b>	<b>BES01HW</b>	<b>BES02Y7</b>
	Part number	BES 516-360-G-S4-H	BES M18ME1-PSC20F-S04G
PNP, NC	<b>Ordering code</b>		
	Part number		
PNP, complementary	<b>Ordering code</b>	<b>BES016W</b>	
	Part number	BES 516-123-G-S4-H	
NPN, NO	<b>Ordering code</b>		<b>BES02Y6</b>
	Part number		BES M18ME1-NSC20F-S04G
NPN, complementary	<b>Ordering code</b>		
	Part number		
Supply voltage $U_S$		10...55 V DC	10...30 V DC
Voltage drop $U_d$ at $I_e$ max.		2.5 V	2 V
Rated insulation voltage $U_i$ (protection class)		250 V AC (□)	75 V DC
Rated operating current $I_e$		200 mA	200 mA
Polarity reversal protected/transposition protected/short-circuit protected		Yes/Yes/Yes	Yes/Yes/Yes
Ambient temperature $T_a$		-25...+70 °C	-25...+70 °C
Switching frequency $f$ max.		80 Hz	200 Hz
Output function indicator		Yellow LED	Yellow LED
Degree of protection as per IEC 60529		IP 68 per BWN Pr. 20	IP 67
Approvals		CE	CE
Special properties			<b>Large switching distance</b>
Material	Housing	Brass-coated	Brass-coated
	Sensing surface	PA 12	PBT
Connection		M12 connector, 4-pin	M12 connector, 4-pin

Wiring diagrams, see page 958.  
The meaning of switching distance markings can be found on page 962.

**Additional cable lengths and PUR cable jacket material available on request**

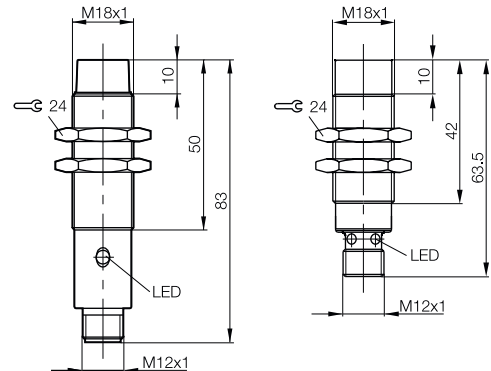

### Reliably monitor speed

Two inductive sensors are sufficient to protect your system from overspeed. Attached to a perforated disk, they determine rotary speed and direction.

- Extremely reliable (HALT, EMC, shocks)
- For extreme conditions (temperature fluctuations)
- Long service life
- Insensitive to contamination

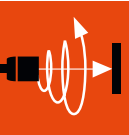

Inductive Sensors

Global DC 3-wire

DC 3-/4-wire

Cylinder Designs  
Block Designs

DC 2-wire

AC/DC 2-wire

AC 2-wire

Special Properties

Analog Distance Measurement

Accessories

M30x1.5	M30x1.5	M30x1.5	M30x1.5	M30x1.5
Flush	Flush	Flush	Flush	Flush
<b>10 mm</b>	<b>10 mm</b>	<b>10 mm</b>	<b>10 mm</b>	<b>10 mm</b>
0...8 mm	0...8.1 mm	0...8.1 mm	0...8.1 mm	0...8.1 mm
■	■	■	■	■
<b>BES00RP</b>	<b>BES01EE</b>	<b>BES02F1</b>		<b>BES00RF</b>
BES 516-327-E5-Y-S4	BES 516-327-S4-C	BES 515-327-S4-C		BES 516-327-E4-Y-02
<b>BES00LM</b>	<b>BES0195</b>			
BES 516-3028-E5-Y-S4	BES 516-3028-S4-C			
	<b>BES0167</b>		<b>BES02E0</b>	
	BES 516-114-S4-C		BES 515-114-S4-C	
<b>BES00W9</b>	<b>BES01HL</b>			<b>BES00W5</b>
BES 516-359-E5-Y-S4	BES 516-359-S4-C			BES 516-359-E4-Y-02
	<b>BES016J</b>			
	BES 516-120-S4-C			
10...30 V DC	10...30 V DC	10...30 V DC	10...30 V DC	10...30 V DC
3.5 V	2.5 V	2.5 V	2.5 V	3.5 V
75 V DC	250 V AC (□)	250 V AC (□)	250 V AC (□)	75 V DC
130 mA	200 mA	200 mA	200 mA	130 mA
Yes/Yes/Yes	Yes/Yes/Yes	Yes/Yes/Yes	Yes/Yes/Yes	Yes/Yes/Yes
-25...+70 °C	-25...+70 °C	-25...+70 °C	-40...+85 °C	-25...+70 °C
200 Hz	300 Hz	300 Hz	300 Hz	200 Hz
Yellow LED	Yellow LED	Yellow LED	Yellow LED	Yellow LED
IP 67	IP 68 per BWN Pr. 20	IP 68 per BWN Pr. 20	IP 68 per BWN Pr. 20	IP 68 per BWN Pr. 20
CE, cULus	CE, cULus	CE, cULus	CE, cULus	CE, cULus
Brass-coated	Brass-coated	Stainless steel	Stainless steel	Brass-coated
PA 12	PA 12	PA 12	PA 12	PA 12
M12 connector, 4-pin	M12 connector, 4-pin	M12 connector, 4-pin	M12 connector, 4-pin	2 m PVC cable, 3x0.34 mm <sup>2</sup>

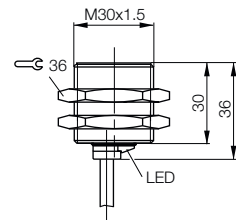
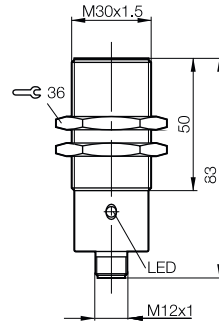
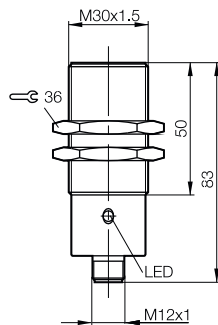
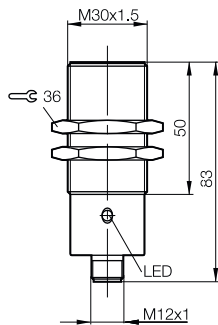
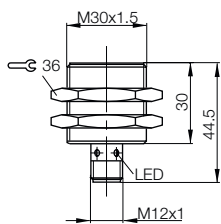

# DC 3-/4-wire Inductive Sensors

## Cylinder designs, M30x1.5



Model		<b>M30x1.5</b>	<b>M30x1.5</b>	<b>M30x1.5</b>
Installation type (observe instructions in the Basic Information chapter)		Flush	Flush	Flush
Rated switching distance $s_n$		<b>10 mm</b>	<b>15 mm</b>	<b>15 mm</b>
Assured switching distance $s_a$		0...8.1 mm	0...12 mm	0...12 mm
Switching distance marking		■	■■	■■■
PNP, NO	<b>Ordering code</b>	<b>BES01E3</b>	<b>BES00RY</b>	<b>BES00RW</b>
	Part number	BES 516-327-BO-C-02	BES 516-327-G-E5-Y-S49	BES 516-327-G-E5-Y-S4
PNP, NC	<b>Ordering code</b>			<b>BES00LU</b>
	Part number			BES 516-3028-G-E5-Y-S4
PNP, complementary	<b>Ordering code</b>			
	Part number			
NPN, NO	<b>Ordering code</b>	<b>BES01HF</b>	<b>BES00WE</b>	
	Part number	BES 516-359-BO-C-02	BES 516-359-G-E5-Y-S49	
Supply voltage $U_s$		10...30 V DC	10...30 V DC	10...30 V DC
Voltage drop $U_d$ at $I_o$ max.		2.5 V	3.5 V	3.5 V
Rated insulation voltage $U_i$ (protection class)		250 V AC (□)	75 V DC	75 V DC
Rated operating current $I_o$		200 mA	130 mA	130 mA
Polarity reversal protected/transposition protected/short-circuit protected		Yes/Yes/Yes	Yes/Yes/Yes	Yes/Yes/Yes
Ambient temperature $T_a$		-25...+70 °C	-25...+70 °C	-25...+70 °C
Switching frequency $f$ max.		300 Hz	100 Hz	100 Hz
Output function indicator		Yellow LED	Yellow LED	Yellow LED
Degree of protection as per IEC 60529		IP 67	IP 67	IP 68 per BWN Pr. 20
Approvals		CE, cULus	CE, cULus	CE, cULus
Special properties				
Material	Housing	Brass-coated	Brass-coated	Brass-coated
	Sensing surface	PA 12	PA 12	PA 12
Connection		2 m PVC cable, 3x0.34 mm <sup>2</sup>	M8 connector, 3-pin	M12 connector, 4-pin

Wiring diagrams, see page 958.  
The meaning of switching distance markings can be found on page 962.

**Additional cable lengths and PUR cable jacket material available on request**

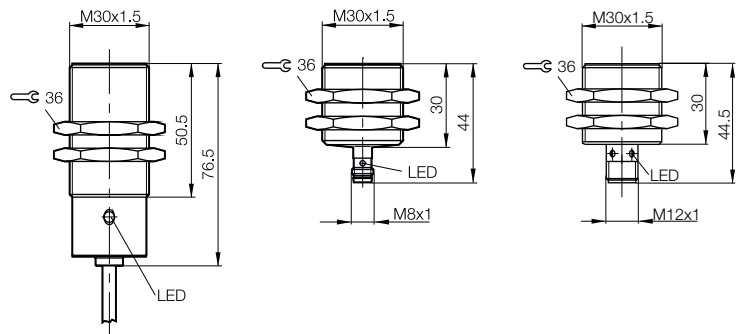





TRIPLEPROX

M30x1.5	M30x1.5	M30x1.5	M30x1.5	M30x1.5
Flush	Flush	Flush	Quasi-flush	Not flush
<b>15 mm</b>	<b>15 mm</b>	<b>15 mm</b>	<b>22 mm</b>	<b>15 mm</b>
0...12 mm	0...12 mm	0...12 mm	0...17.6 mm	0...12.2 mm
■ ■	■ ■	■ ■	■ ■ ■	■
<b>BES01EA</b>	<b>BES01EC</b>	<b>BES00RR</b>	<b>BES02YM</b>	<b>BES00Y0</b>
BES 516-327-G-S4-C	BES 516-327-G-S4-H	BES 516-327-G-E4-Y-02	BES M30MI1-PSC22B-S04G	BES 516-362-E5-Y-S4
		<b>BES00LN</b>	<b>BES02YL</b>	<b>BES00LZ</b>
		BES 516-3028-G-E4-Y-02	BES M30MI1-POC22B-S04G	BES 516-3029-E5-Y-S4
	<b>BES0166</b>			<b>BES00Y4</b>
	BES 516-114-G-S4-H			BES 516-363-E5-Y-S4
		<b>BES00WA</b>	<b>BES02YK</b>	
		BES 516-359-G-E4-Y-02	BES M30MI1-NSC22B-S04G	
10...30 V DC	10...55 V DC	10...30 V DC	10...30 V DC	10...30 V DC
2.5 V	2.5 V	3.5 V	2 V	3.5 V
250 V AC (□)	250 V AC (□)	75 V DC	75 V DC	75 V DC
200 mA	200 mA	130 mA	200 mA	130 mA
Yes/Yes/Yes	Yes/Yes/Yes	Yes/Yes/Yes	Yes/Yes/Yes	Yes/Yes/Yes
-25...+70 °C	-25...+70 °C	-25...+70 °C	-25...+70 °C	-25...+70 °C
100 Hz	150 Hz	100 Hz	200 Hz	100 Hz
Yellow LED	Yellow LED	Yellow LED	Yellow LED	Yellow LED
IP 67	IP 68 per BWN Pr. 20	IP 68 per BWN Pr. 20	IP 67	IP 67
CE, cULus	CE	CE, cULus	CE	CE, cULus
			<b>Large switching distance</b>	
Brass-coated	Brass-coated	Brass-coated	Brass-coated	Brass-coated
PA 12	PA 12	PA 12	PBT	PA 12
M12 connector, 4-pin	M12 connector, 4-pin	2 m PVC cable, 3x0.34 mm <sup>2</sup>	M12 connector, 4-pin	M12 connector, 4-pin

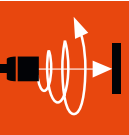

Inductive Sensors  
Global DC 3-wire  
DC 3-/4-wire  
Cylinder Designs  
Block Designs  
DC 2-wire  
AC/DC 2-wire  
AC 2-wire  
Special Properties  
Analog Distance Measurement  
Accessories

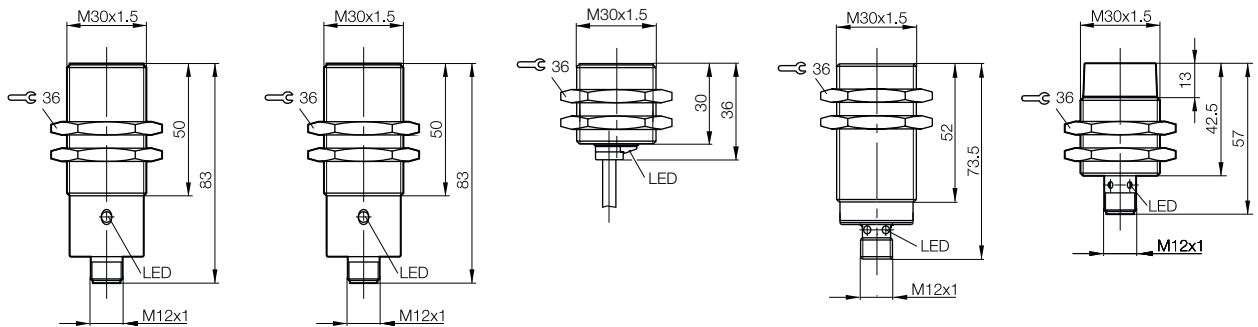

# DC 3-/4-wire Inductive Sensors

## Cylinder designs, M30x1.5



Model		<b>M30x1.5</b>	<b>M30x1.5</b>	<b>M30x1.5</b>
Installation type (observe instructions in the Basic Information chapter)		Not flush	Not flush	Not flush
Rated switching distance $s_n$		<b>15 mm</b>	<b>15 mm</b>	<b>15 mm</b>
Assured switching distance $s_a$		0...12.2 mm	0...12.2 mm	0...12.2 mm
Switching distance marking		■	■	■
PNP, NO	<b>Ordering code</b>	<b>BES01JE</b>	<b>BES03AL</b>	<b>BES01JF</b>
	Part number	BES 516-362-S4-C	BES M30ML-PSC15F-S04G-002	BES 516-362-S4-H
PNP, NC	<b>Ordering code</b>	<b>BES0198</b>		
	Part number	BES 516-3029-S4-C		
PNP, complementary	<b>Ordering code</b>	<b>BES0173</b>		
	Part number	BES 516-125-S4-C		
NPN, NO	<b>Ordering code</b>	<b>BES01JN</b>	<b>BES03AT</b>	
	Part number	BES 516-363-S4-C	BES M30ML-NSC15F-S04G-002	
NPN, NC	<b>Ordering code</b>	<b>BES019N</b>		
	Part number	BES 516-3033-S4-C		
Supply voltage $U_s$		10...30 V DC	10...30 V DC	10...55 V DC
Voltage drop $U_d$ at $I_o$ max.		2.5 V	2.5 V	1.5 V
Rated insulation voltage $U_i$ (protection class)		250 V AC (□)	250 V AC (□)	250 V AC (□)
Rated operating current $I_o$		200 mA	200 mA	200 mA
Polarity reversal protected/transposition protected/short-circuit protected		Yes/Yes/Yes	Yes/Yes/Yes	Yes/Yes/Yes
Ambient temperature $T_a$		-25...+70 °C	-25...+70 °C	-25...+70 °C
Switching frequency $f$ max.		100 Hz	75 Hz	400 Hz
Output function indicator		Yellow LED	Yellow LED	Yellow LED
Degree of protection as per IEC 60529		IP 68 per BWN Pr. 20	IP 67	IP 68 per BWN Pr. 20
Approvals		CE, cULus	CE	CE
Special properties				
Material	Housing	Brass-coated	Brass-coated	Brass-coated
	Sensing surface	PA 12	PA 12	PA 12
Connection		M12 connector, 4-pin	M12 connector, 4-pin	M12 connector, 4-pin

Wiring diagrams, see page 958.  
The meaning of switching distance markings can be found on page 962.

**Additional cable lengths and PUR cable jacket material available on request**

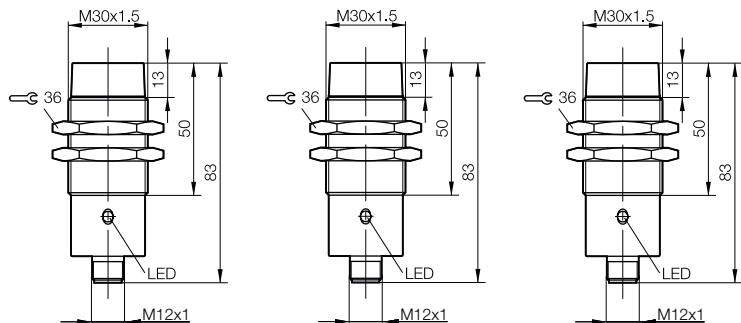

# DC 3-/4-wire Inductive Sensors Cylinder designs, M30x1.5



**TRIPLEPROX**

M30x1.5	M30x1.5	M30x1.5	M30x1.5	M30x1.5
Not flush	Not flush	Not flush	Not flush	Not flush
<b>15 mm</b>	<b>15 mm</b>	<b>15 mm</b>	<b>30 mm</b>	<b>40 mm</b>
0...12.2 mm	0...12.2 mm	0...12.2 mm	0...24.00 mm	0...32 mm
■	■	■	■ ■	■ ■ ■
<b>BES02FN</b>	<b>BES00WU</b>	<b>BES01J6</b>	<b>BES01JC</b>	<b>BES02YJ</b>
BES 515-362-S4-C	BES 516-362-E4-Y-02	BES 516-362-BO-C-02	BES 516-362-G-S4-H	BES M30MG1-PSC40F-S04G
	<b>BES00LW</b>			
	BES 516-3029-E4-Y-02			
		<b>BES01JJ</b>		
		BES 516-363-BO-C-02		
	<b>BES00Y1</b>	<b>BES019L</b>		<b>BES02YH</b>
	BES 516-363-E4-Y-02	BES 516-3033-BO-C-02		BES M30MG1-NSC40F-S04G
10...30 V DC	10...30 V DC	10...30 V DC	10...55 V DC	10...30 V DC
2.5 V	3.5 V	2.5 V	2.5 V	2 V
250 V AC (□)	75 V DC	250 V AC (□)	250 V AC	75 V DC
200 mA	130 mA	200 mA	200 mA	200 mA
Yes/Yes/Yes	Yes/Yes/Yes	Yes/Yes/Yes	Yes/Yes/Yes	Yes/Yes/Yes
-25...+70 °C	-25...+70 °C	-25...+70 °C	-25...+70 °C	-25...+70 °C
100 Hz	100 Hz	100 Hz	70 Hz	100 Hz
Yellow LED	Yellow LED	Yellow LED	Yellow LED	Yellow LED
IP 68 per BWN Pr. 20	IP 68 per BWN Pr. 20	IP 68 per BWN Pr. 20	IP 68 per BWN Pr. 20	IP 54
CE, cULus	CE, cULus	CE, cULus	CE	CE
				<b>Large switching distance</b>
Stainless steel	Brass-coated	Brass-coated	Brass-coated	Brass-coated
PA 12	PA 12	PA 12	PA 12	PBT
M12 connector, 4-pin	2 m PVC cable, 3x0.34 mm	2 m PVC cable, 3x0.34 mm	M12 connector, 4-pin	M12 connector, 4-pin

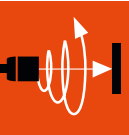

- Inductive Sensors
- Global DC 3-wire
- DC 3-/4-wire
- Cylinder Designs
- Block Designs
- DC 2-wire
- AC/DC 2-wire
- AC 2-wire
- Special Properties
- Analog Distance Measurement
- Accessories

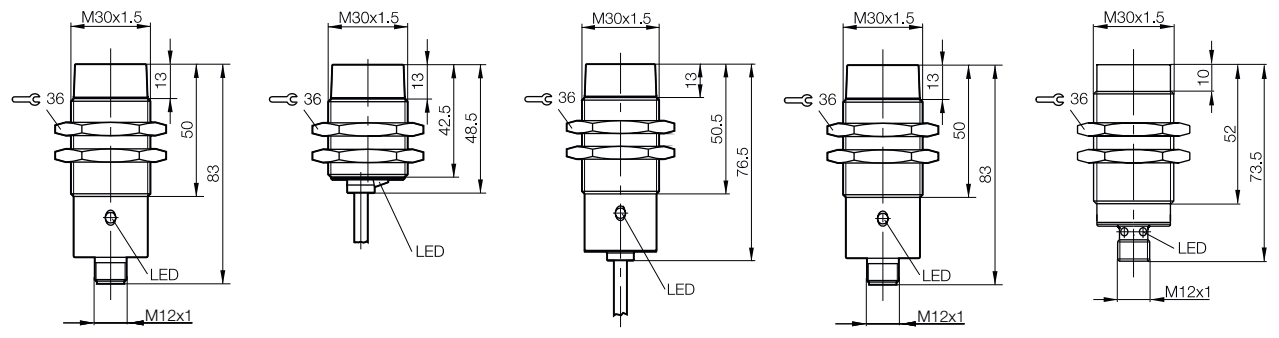

# DC 3-/4-wire Inductive Sensors

## Block design, 5x5 mm

### Five good reasons for using inductive 5x5 sensors

- One rugged, compact metal housing
- Two switching distance variants (flush mountable): 0.8 mm for high-precision applications, new 1.5 mm for more function reserve
- Three connections: Supply (+), Ground (-), Output. Easy to integrate into standard and special controllers.
- Four interface variants: PNP or NPN, normally open or normally closed
- Five millimeter installation height in the sensing direction

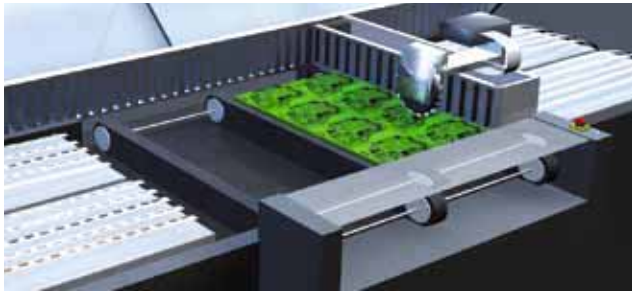

**Electronics manufacturing:** Mechatronic modules require miniature sensors. Balluff offers mini.s in the highest degree of precision.

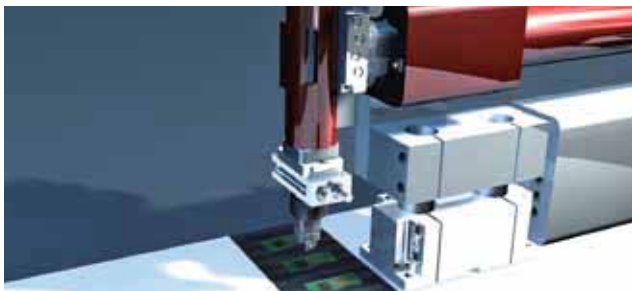

**Robotics automation:** The trend towards miniaturization continues. Balluff is leading the way.



**Punching/reshaping technology:** Workpieces are getting smaller and smaller. Balluff sensors adapt to this.

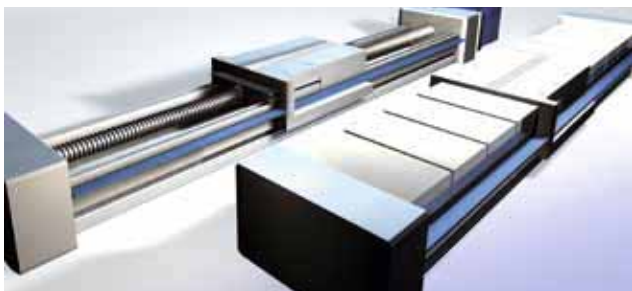

**Linear technology:** Position detection in a simple manner through mini designs with maximum performance.

Model		
Installation type (observe instructions in the Basic Information chapter)		
Rated switching distance $s_n$		
Assured switching distance $s_a$		
Switching distance marking		
PNP, NO	<b>Ordering code</b>	
	Part number	
PNP, NC	<b>Ordering code</b>	
	Part number	
NPN, NO	<b>Ordering code</b>	
	Part number	
NPN, NC	<b>Ordering code</b>	
	Part number	
Supply voltage $U_S$		
Voltage drop $U_d$ at $I_o$ max.		
Rated insulation voltage $U_i$		
Rated operating current $I_o$		
Polarity reversal protected/transposition protected/short-circuit protected		
Ambient temperature $T_a$		
Switching frequency $f$ max.		
Output function indicator		
Degree of protection as per IEC 60529		
Approvals		
Special properties		
Material	Housing	
	Sensing surface	
Connection		

Wiring diagrams, see page 958.  
The meaning of switching distance markings can be found on page 962.

**Additional cable lengths on request.**



5x5 mm	5x5 mm	5x5 mm	5x5 mm	5x5 mm	5x5 mm
Flush	Flush	Flush	Flush	Flush	Flush
<b>0.8 mm</b>	<b>0.8 mm</b>	<b>0.8 mm</b>	<b>0.8 mm</b>	<b>0.8 mm</b>	<b>0.8 mm</b>
0...0.65 mm	0...0.65 mm	0...0.65 mm	0...0.65 mm	0...0.65 mm	0...0.65 mm
■	■	■	■	■	■
<b>BES01RM</b>	<b>BES01ZF</b>	<b>BES019W</b>	<b>BES019T</b>	<b>BES019P</b>	<b>BES019P</b>
BES Q05AC-PSC08B-S26G	BES 516-3040-I02-C-S49	BES 516-3040-I02-C-S49-00,3	BES 516-3040-I02-C-S4-00,3	BES 516-3040-I02-C-PU-02	BES 516-3040-I02-C-PU-02
<b>BES01RH</b>	<b>BES01ZH</b>			<b>BES01A1</b>	BES 516-3042-I02-C-PU-02
BES Q05AC-POC08B-S26G	BES 516-3042-I02-C-S49			<b>BES019Y</b>	BES 516-3041-I02-C-PU-02
<b>BES01RA</b>	<b>BES01A0</b>			<b>BES01A3</b>	BES 516-3043-I02-C-PU-02
BES Q05AC-NSC08B-S26G	BES 516-3041-I02-C-S49			BES 516-3043-I02-C-PU-02	
<b>BES01R6</b>	<b>BES01A5</b>				
BES Q05AC-NOC08B-S26G	BES 516-3043-I02-C-S49				
10...30 V DC	10...30 V DC	10...30 V DC	10...30 V DC	10...30 V DC	10...30 V DC
2.5 V	2.5 V	2.5 V	2.5 V	2.5 V	2.5 V
75 V DC	75 DC	75 V DC	75 V DC	75 V DC	75 V DC
100 mA	100 mA	100 mA	100 mA	100 mA	100 mA
Yes/Yes/Yes	Yes/Yes/Yes	Yes/Yes/Yes	Yes/Yes/Yes	Yes/Yes/Yes	Yes/Yes/Yes
-25...+70 °C	-25...+70 °C	-25...+70 °C	-25...+70 °C	-25...+70 °C	-25...+70 °C
3 kHz	3 kHz	3 kHz	3 kHz	3 kHz	3 kHz
Yellow LED	Yellow LED	Yellow LED	Yellow LED	Yellow LED	Yellow LED
IP 67	IP 67	IP 67	IP 67	IP 67	IP 67
CE, cULus	CE, cULus	CE, cULus	CE, cULus	CE, cULus	CE, cULus
<b>Narrow design</b>	<b>Narrow design</b>	<b>Narrow design</b>	<b>Narrow design</b>	<b>Narrow design</b>	<b>Narrow design</b>
Anodized aluminum	Anodized aluminum	Anodized aluminum	Anodized aluminum	Anodized aluminum	Anodized aluminum
PBT	PBT	PBT	PBT	PBT	PBT
M5 connector, 3-pin	M8 connector, 3-pin	0.3 m PUR cable with M8 connector, 3-pin	0.3 m PUR cable with M12 connector, 4-pin	2 m PUR cable, 3x0.14 mm <sup>2</sup>	

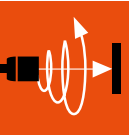

- Inductive Sensors
- Global DC 3-wire
- DC 3-/4-wire
- Cylinder Designs
- Block Designs
- DC 2-wire
- AC/DC 2-wire
- AC 2-wire
- Special Properties
- Analog Distance Measurement
- Accessories

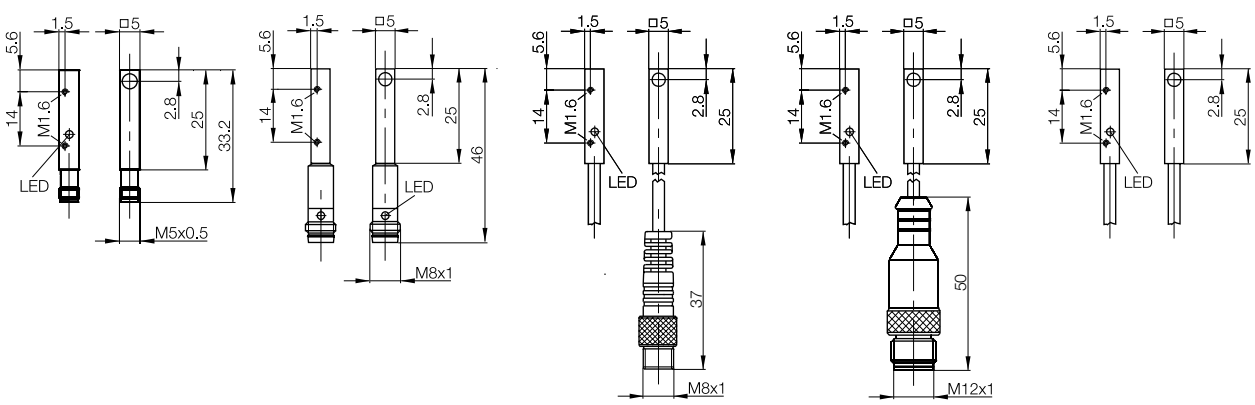

# DC 3-/4-wire Inductive Sensors

## Block design, 5x5 mm



Model		<b>5x5 mm</b>	<b>5x5 mm</b>	<b>5x5 mm</b>	
Installation type (observe instructions in the Basic Information chapter)		Flush	Flush	Flush	
Rated switching distance $s_n$		<b>1.5 mm</b>	<b>1.5 mm</b>	<b>1.5 mm</b>	
Assured switching distance $s_a$		0...1.2 mm	0...1.2 mm	0...1.2 mm	
Switching distance marking		■ ■	■ ■	■ ■	
PNP, NO	<b>Ordering code</b>	<b>BES01RP</b>	<b>BES01RR</b>	<b>BES03UW</b>	
	Part number	BES Q05AC-PSC15B-S26G	BES Q05AC-PSC15B-S49G	BES Q05AC-PSC15B-EP00,3-GS49	
PNP, NC	<b>Ordering code</b>	<b>BES01RK</b>	<b>BES01RL</b>		
	Part number	BES Q05AC-POC15B-S26G	BES Q05AC-POC15B-S49G		
NPN, NO	<b>Ordering code</b>	<b>BES01RE</b>	<b>BES01RF</b>		
	Part number	BES Q05AC-NSC15B-S26G	BES Q05AC-NSC15B-S49G		
NPN, NC	<b>Ordering code</b>	<b>BES01R8</b>	<b>BES01R9</b>		
	Part number	BES Q05AC-NOC15B-S26G	BES Q05AC-NOC15B-S49G		
Supply voltage $U_s$		10...30 V DC	10...30 V DC	10...30 V DC	
Voltage drop $U_d$ at $I_o$ max.		2.5 V	3 V	3 V	
Rated insulation voltage $U_i$		75 V DC	75 V DC	75 V DC	
Rated operating current $I_o$		100 mA	100 mA	100 mA	
Polarity reversal protected/transposition protected/short-circuit protected		Yes/Yes/Yes	Yes/Yes/Yes	Yes/Yes/Yes	
Ambient temperature $T_a$		-25...+70 °C	-25...+70 °C	-25...+70 °C	
Switching frequency $f$ max.		2 kHz	2 kHz	2 kHz	
Output function indicator		Yellow LED	Yellow LED	Yellow LED	
Degree of protection as per IEC 60529		IP 67	IP 67	IP 67	
Approvals		CE, cULus	CE, cULus	CE, cULus	
Special properties		<b>Narrow design</b>	<b>Narrow design</b>	<b>Narrow design</b>	
Material	Housing	Stainless steel	Stainless steel	Stainless steel	
	Sensing surface	PBT	PBT	PBT	
Connection		M5 connector, 3-pin	M8 connector, 3-pin	0.3 m PUR cable with M8 connector, 3-pin	

Wiring diagrams, see page 958.

The meaning of switching distance markings can be found on page 962.

**Additional cable lengths on request.**

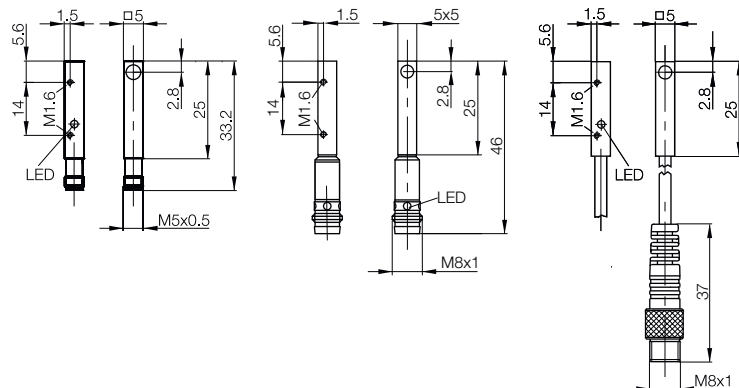



# DC 3-/4-wire Inductive Sensors

## Block design, 5x5 mm

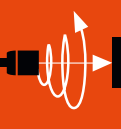

<b>5x5 mm</b>				
Flush				
<b>1.5 mm</b>				
0...1.2 mm				
■ ■				
<b>BES01RN</b>				
BES Q05AC-PSC15B-EP02				
<b>BES01RJ</b>				
BES Q05AC-POC15B-EP02				
<b>BES01RC</b>				
BES Q05AC-NSC15B-EP02				
<b>BES01R7</b>				
BES Q05AC-NOC15B-EP02				
10...30 V DC				
3 V				
75 V DC				
100 mA				
Yes/Yes/Yes				
-25...+70 °C				
2 kHz				
Yellow LED				
IP 67				
CE, cULus				
<b>Narrow design</b>				
Stainless steel				
PBT				
2 m PUR cable, 3x0.14 mm <sup>2</sup>				

- Inductive Sensors
- Global DC 3-wire
- DC 3-/4-wire
- Cylinder Designs
- Block Designs
- DC 2-wire
- AC/DC 2-wire
- AC 2-wire
- Special Properties
- Analog Distance Measurement
- Accessories

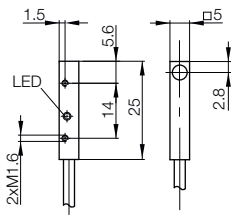

# DC 3-/4-wire Inductive Sensors

## Block design, 8x8 mm



**SUPERSHORTIES**



**SUPERSHORTIES**



Model		8x8 mm	8x8 mm	8x8 mm
Installation type (observe instructions in the Basic Information chapter)		Flush	Flush	Flush
Rated switching distance $s_n$		<b>1.5 mm</b>	<b>1.5 mm</b>	<b>1.5 mm</b>
Assured switching distance $s_a$		0...1.2 mm	0...1.2 mm	0...1.2 mm
Switching distance marking		■	■	■
PNP, NO	<b>Ordering code</b>	<b>BES03U1</b>	<b>BES03Y6</b>	<b>BES0180</b>
	Part number	BES Q08MEC-PSC15B-S26G	BES Q08MEC-PSC15B-S49G	BES 516-300-S166-S49
PNP, NC	<b>Ordering code</b>	<b>BES03YE</b>	<b>BES03U0</b>	<b>BES0187</b>
	Part number	BES Q08MEC-POC15B-S26G	BES Q08MEC-POC15B-S49G	BES 516-300-S180-S49
NPN, NO	<b>Ordering code</b>	<b>BES03Y7</b>	<b>BES03U8</b>	<b>BES0184</b>
	Part number	BES Q08MEC-NSC15B-S26G	BES Q08MEC-NSC15B-S49G	BES 516-300-S170-S49
NPN, NC	<b>Ordering code</b>	<b>BES03U9</b>	<b>BES03YC</b>	<b>BES018H</b>
	Part number	BES Q08MEC-NOC15B-S26G	BES Q08MEC-NOC15B-S49G	BES 516-300-S264-S49
Supply voltage $U_s$		10...30 V DC	10...30 V DC	10...30 V DC
Voltage drop $U_d$ at $I_o$ max.		2.8 V	2.8 V	2.5 V
Rated insulation voltage $U_i$		75 V DC	75 V DC	75 V DC
Rated operating current $I_o$		200 mA	200 mA	200 mA
Polarity reversal protected/transposition protected/short-circuit protected		Yes/Yes/Yes	Yes/Yes/Yes	Yes/Yes/Yes
Ambient temperature $T_a$		-25...+70 °C	-25...+70 °C	-25...+70 °C
Switching frequency $f$ max.		3 kHz	3 kHz	5 kHz
Output function indicator		Yellow LED	Yellow LED	Yellow LED
Degree of protection as per IEC 60529		IP 67	IP 67	IP 67
Approvals		CE, cULus	CE, cULus	CE, cULus
Special properties		<b>Short design</b>	<b>Short design</b>	
Material	Housing	Brass-coated	Brass-coated	Cast zinc
	Sensing surface	PBT	PBT	PBT
Connection		M5 connector, 3-pin	M8 connector, 3-pin	M8 connector, 3-pin

Wiring diagrams, see page 958.  
The meaning of switching distance markings can be found on page 962.

**Additional cable lengths and PUR cable jacket material available on request**

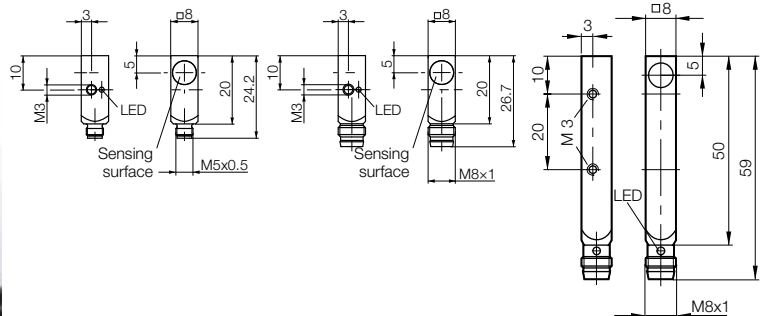



# DC 3-/4-wire Inductive Sensors

## Block design, 8x8 mm



**SUPER**SHORTIES



**SUPER**SHORTIES



**SUPER**SHORTIES



**SUPER**SHORTIES

8x8 mm	8x8 mm	8x8 mm	8x8 mm	8x8 mm
Flush	Flush	Flush	Flush	Flush
<b>1.5 mm</b>	<b>1.5 mm</b>	<b>1.5 mm</b>	<b>1.5 mm</b>	<b>2 mm</b>
0...1.2 mm	0...1.2 mm	0...1.2 mm	0...1.2 mm	0...1.6 mm
■	■	■	■	■ ■
<b>BES041J</b>	<b>BES041C</b>	<b>BES03TZ</b>	<b>BES017R</b>	<b>BES03U4</b>
BES Q08MEC-PSC15B-EP00,3-GS26	BES Q08MEC-PSC15B-EP00,3-GS49	BES Q08MEC-PSC15B-EP02	BES 516-300-S166-02	BES Q08MEC-PSC20B-S26G
<b>BES041K</b>	<b>BES041E</b>	<b>BES03Y5</b>		<b>BES03YH</b>
BES Q08MEC-POC15B-EP00,3-GS26	BES Q08MEC-POC15B-EP00,3-GS49	BES Q08MEC-POC15B-EP02		BES Q08MEC-POC20B-S26G
<b>BES041L</b>	<b>BES041F</b>	<b>BES03YA</b>		<b>BES03Y9</b>
BES Q08MEC-NSC15B-EP00,3-GS26	BES Q08MEC-NSC15B-EP00,3-GS49	BES Q08MEC-NSC15B-EP02		BES Q08MEC-NSC20B-S26G
<b>BES041M</b>	<b>BES041H</b>	<b>BES03U7</b>		<b>BES03UE</b>
BES Q08MEC-NOC15B-EP00,3-GS26	BES Q08MEC-NOC15B-EP00,3-GS49	BES Q08MEC-NOC15B-EP02		BES Q08MEC-NOC20B-S26G
10...30 V DC	10...30 V DC	10...30 V DC	10...30 V DC	10...30 V DC
2.8 V	2.8 V	2.8 V	2.5 V	2.8 V
75 V DC	75 V DC	75 V DC	75 V DC	75 V DC
200 mA	200 mA	200 mA	200 mA	200 mA
Yes/Yes/Yes	Yes/Yes/Yes	Yes/Yes/Yes	Yes/Yes/Yes	Yes/Yes/Yes
-25...+70 °C	-25...+70 °C	-25...+70 °C	-25...+70 °C	-25...+70 °C
3 kHz	3 kHz	3 kHz	3 kHz	3 kHz
Yellow LED	Yellow LED	Yellow LED	Yellow LED	Yellow LED
IP 67	IP 67	IP 67	IP 67	IP 67
CE, cULus	CE, cULus	CE, cULus	CE, cULus	CE, cULus
<b>Short design</b>	<b>Short design</b>	<b>Short design</b>		<b>Short design</b>
Brass-coated	Brass-coated	Brass-coated	Cast zinc	Brass-coated
PBT	PBT	PBT	PBT	PBT
0.3 m PUR cable with M5 connector, 3-pin	0.3 m PUR cable with M8 connector, 3-pin	2 m PUR cable, 3x0.14 mm <sup>2</sup>	2 m PVC cable, 3x0.14 mm <sup>2</sup>	M5 connector, 3-pin

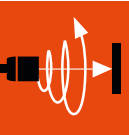

- Inductive Sensors
- Global DC 3-wire
- DC 3-/4-wire
- Cylinder Designs
- Block Designs
- DC 2-wire
- AC/DC 2-wire
- AC 2-wire
- Special Properties
- Analog Distance Measurement
- Accessories

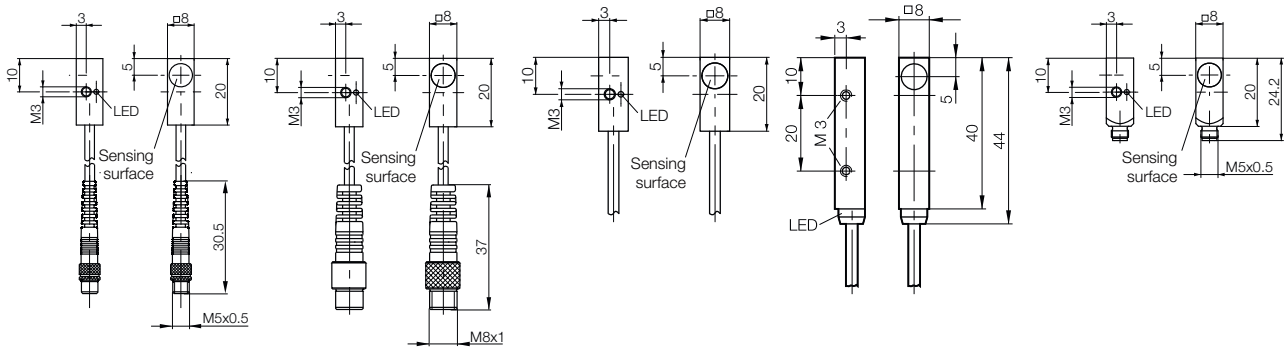

# DC 3-/4-wire Inductive Sensors

## Block design, 8x8 mm



Model		<b>8x8 mm</b>	<b>8x8 mm</b>	<b>8x8 mm</b>
Installation type (observe instructions in the Basic Information chapter)		Flush	Flush	Flush
Rated switching distance $s_n$		<b>1.5 mm</b>	<b>1.5 mm</b>	<b>1.5 mm</b>
Assured switching distance $s_a$		0...1.2 mm	0...1.2 mm	0...1.2 mm
Switching distance marking		■	■	■
PNP, NO	<b>Ordering code</b>	<b>BES018C</b>	<b>BES0189</b>	<b>BES0188</b>
	Part number	BES 516-300-S202-S49	BES 516-300-S202-02	BES 516-300-S202-00,3-S4
PNP, NC	<b>Ordering code</b>	<b>BES018J</b>		
	Part number	BES 516-300-S272-S49		
NPN, NO	<b>Ordering code</b>			
	Part number			
NPN, NC	<b>Ordering code</b>			
	Part number			
Supply voltage $U_s$		10...30 V DC	10...30 V DC	10...30 V DC
Voltage drop $U_d$ at $I_o$ max.		2.5 V	2.5 V	2.5 V
Rated insulation voltage $U_i$		75 V DC	75 V DC	75 V DC
Rated operating current $I_o$		200 mA	200 mA	200 mA
Polarity reversal protected/transposition protected/short-circuit protected		Yes/Yes/Yes	Yes/Yes/Yes	Yes/Yes/Yes
Ambient temperature $T_a$		-25...+70 °C	-25...+70 °C	-25...+70 °C
Switching frequency $f$ max.		5 kHz	5 kHz	5 kHz
Output function indicator		Yellow LED	Yellow LED	Yellow LED
Degree of protection as per IEC 60529		IP 67	IP 67	IP 67
Approvals		CE, cULus	CE, cULus	CE, cULus
Special properties				
Material	Housing	Cast zinc	Cast zinc	Cast zinc
	Sensing surface	PBT	PBT	PBT
Connection		M8 connector, 3-pin	2 m PVC cable, 3x0.14 mm <sup>2</sup>	0.3 m PUR cable with M12 connector, 4-pin

Wiring diagrams, see page 958.  
The meaning of switching distance markings can be found on page 962.

**Additional cable lengths on request.**

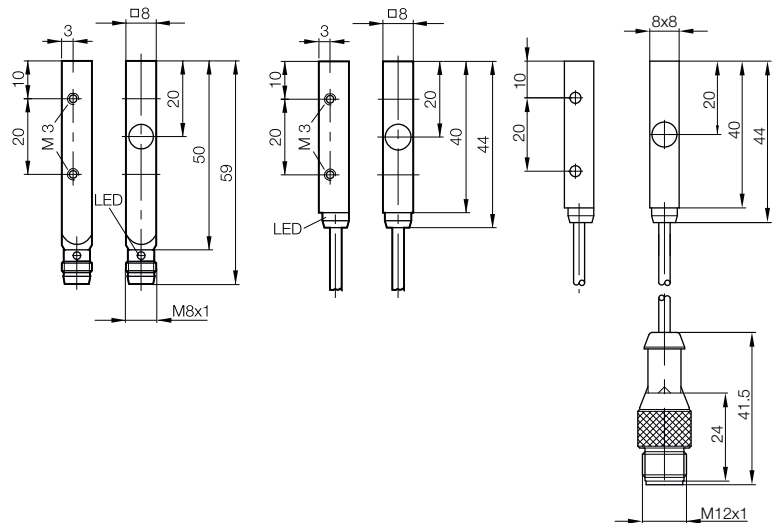



SUPERSHORTIES		SUPERSHORTIES		SUPERSHORTIES	
<b>8x8 mm</b>	<b>8x8 mm</b>	<b>8x8 mm</b>	<b>8x8 mm</b>	<b>8x8 mm</b>	<b>8x8 mm</b>
Flush	Flush	Flush	Flush	Flush	Flush
<b>2 mm</b>	<b>2 mm</b>	<b>2 mm</b>	<b>2 mm</b>	<b>2 mm</b>	<b>2 mm</b>
0...1.6 mm	0...1.6 mm	0...1.6 mm	0...1.6 mm	0...1.6 mm	0...1.6 mm
■ ■	■ ■	■ ■	■ ■	■ ■	■ ■
<b>BES03Y8</b>	<b>BES01U2</b>	<b>BES01UW</b>	<b>BES041U</b>	<b>BES041N</b>	
BES Q08MEC-PSC20B-S49G	BES Q08ZC-PSC20B-S49G	BES Q08ZE-PSC20B-S49G	BES Q08MEC-PSC20B-EP00,3-GS26	BES Q08MEC-PSC20B-EP00,3-GS49	
<b>BES03U3</b>	<b>BES01TF</b>	<b>BES01UK</b>	<b>BES041W</b>	<b>BES041P</b>	
BES Q08MEC-POC20B-S49G	BES Q08ZC-POC20B-S49G	BES Q08ZE-POC20B-S49G	BES Q08MEC-POC20B-EP00,3-GS26	BES Q08MEC-POC20B-EP00,3-GS49	
<b>BES03UC</b>	<b>BES01T3</b>	<b>BES01UC</b>	<b>BES041Y</b>	<b>BES041R</b>	
BES Q08MEC-NSC20B-S49G	BES Q08ZC-NSC20B-S49G	BES Q08ZE-NSC20B-S49G	BES Q08MEC-NSC20B-EP00,3-GS26	BES Q08MEC-NSC20B-EP00,3-GS49	
<b>BES03YJ</b>	<b>BES01RW</b>	<b>BES01U6</b>	<b>BES041Z</b>	<b>BES041T</b>	
BES Q08MEC-NOC20B-S49G	BES Q08ZC-NOC20B-S49G	BES Q08ZE-NOC20B-S49G	BES Q08MEC-NOC20B-EP00,3-GS26	BES Q08MEC-NOC20B-EP00,3-GS49	
10...30 V DC	10...30 V DC	10...30 V DC	10...30 V DC	10...30 V DC	
2.8 V	2.5 V	2.5 V	2.8 V	2.8 V	
75 V DC	75 V DC	75 V DC	75 V DC	75 V DC	
200 mA	200 mA	200 mA	200 mA	200 mA	
Yes/Yes/Yes	Yes/Yes/Yes	Yes/Yes/Yes	Yes/Yes/Yes	Yes/Yes/Yes	
-25...+70 °C	-25...+70 °C	-25...+70 °C	-25...+70 °C	-25...+70 °C	
3 kHz	3 kHz	3 kHz	3 kHz	3 kHz	
Yellow LED	Yellow LED	Yellow LED	Yellow LED	Yellow LED	
IP 67	IP 67	IP 67	IP 67	IP 67	
CE, cULus	CE, cULus	CE, cULus	CE, cULus	CE, cULus	
<b>Short design</b>			<b>Short design</b>	<b>Short design</b>	
Brass-coated	Cast zinc	Cast zinc	Brass-coated	Brass-coated	
PBT	PBT	PBT	PBT	PBT	
M8 connector, 3-pin	M8 connector, 3-pin	M8 connector, 3-pin	0.3 m PUR cable with M5 connector, 3-pin	0.3 m PUR cable with M8 connector, 3-pin	

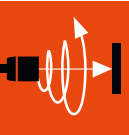

- Inductive Sensors
- Global DC 3-wire
- DC 3-/4-wire
- Cylinder Designs
- Block Designs
- DC 2-wire
- AC/DC 2-wire
- AC 2-wire
- Special Properties
- Analog Distance Measurement
- Accessories

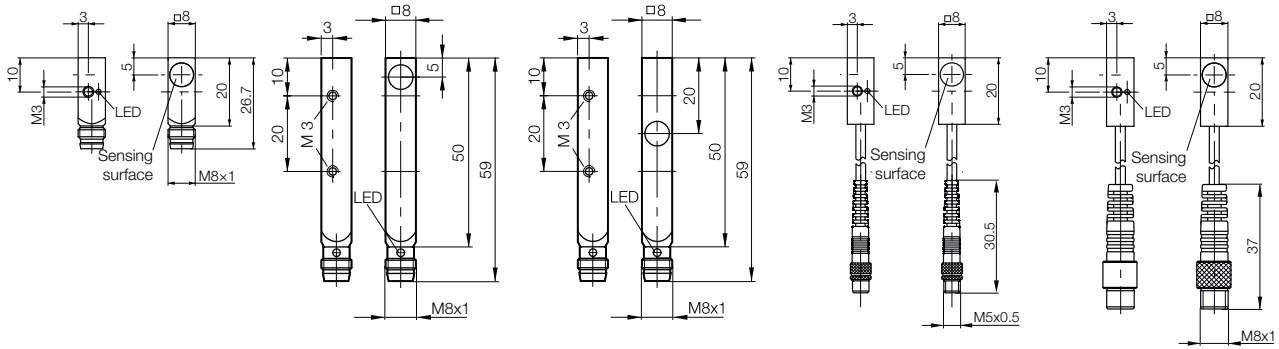

# DC 3-/4-wire Inductive Sensors

## Block design, 8x8 mm



**SUPERSHORTIES**

Model		<b>8x8 mm</b>	<b>8x8 mm</b>	<b>8x8 mm</b>
Installation type (observe instructions in the Basic Information chapter)		Flush	Flush	Flush
Rated switching distance $s_n$		<b>2 mm</b>	<b>2 mm</b>	<b>2 mm</b>
Assured switching distance $s_a$		0...1.6 mm	0...1.6 mm	0...1.6 mm
Switching distance marking		■ ■	■ ■	■ ■
PNP, NO	<b>Ordering code</b>	<b>BES03U2</b>	<b>BES01TZ</b>	<b>BES01TN</b>
	Part number	BES Q08MEC-PSC20B-EP02	BES Q08ZC-PSC20B-BV02	BES Q08ZC-PSC20B-BP02
PNP, NC	<b>Ordering code</b>	<b>BES03YK</b>	<b>BES01TA</b>	<b>BES01T7</b>
	Part number	BES Q08MEC-POC20B-EP02	BES Q08ZC-POC20B-BV02	BES Q08ZC-POC20B-BP02
NPN, NO	<b>Ordering code</b>		<b>BES01T2</b>	<b>BES01RZ</b>
	Part number		BES Q08ZC-NSC20B-BV02	BES Q08ZC-NSC20B-BP02
NPN, NC	<b>Ordering code</b>	<b>BES03UA</b>	<b>BES01RU</b>	<b>BES01TL</b>
	Part number	BES Q08MEC-NOC20B-EP02	BES Q08ZC-NOC20B-BV02	BES Q08ZC-NOC20B-BP02
Supply voltage $U_s$		10...30 V DC	10...30 V DC	10...30 V DC
Voltage drop $U_d$ at $I_o$ max.		2.8 V	2.5 V	2.5 V
Rated insulation voltage $U_i$		75 V DC	75 V DC	75 V DC
Rated operating current $I_o$		200 mA	200 mA	200 mA
Polarity reversal protected/transposition protected/short-circuit protected		Yes/Yes/Yes	Yes/Yes/Yes	Yes/Yes/Yes
Ambient temperature $T_a$		-25...+70 °C	-25...+70 °C	-25...+70 °C
Switching frequency $f$ max.		3 kHz	3 kHz	3 kHz
Output function indicator		Yellow LED	Yellow LED	Yellow LED
Degree of protection as per IEC 60529		IP 67	IP 67	IP 67
Approvals		CE, cULus	CE, cULus	CE, cULus
Special properties				
Material	Housing	Brass-coated	Cast zinc	Cast zinc
	Sensing surface	PBT	PBT	PBT
Connection		2 m PUR cable,	2 m PVC cable,	2 m PUR cable,
		3x0.14 mm <sup>2</sup>	3x0.14 mm <sup>2</sup>	3x0.14 mm <sup>2</sup>

Wiring diagrams, see page 958.  
The meaning of switching distance markings can be found on page 962.

**Additional cable lengths and PUR cable jacket material available on request**

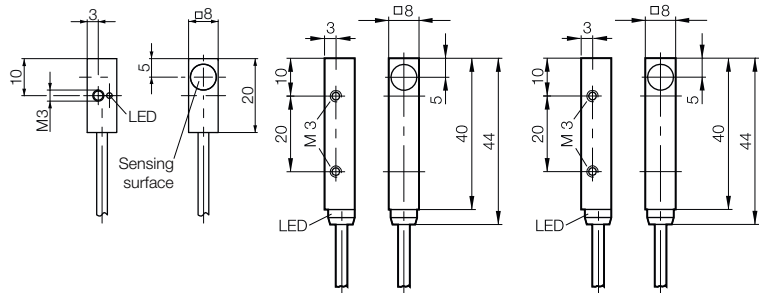



TRIPLEPROX

<b>8x8 mm</b> Flush <b>2 mm</b> 0...1.6 mm ■ ■	<b>8x8 mm</b> Flush <b>2 mm</b> 0...1.6 mm ■ ■	<b>8x8 mm</b> Quasi-flush <b>3 mm</b> 0...2.4 mm ■ ■ ■		
<b>BES01UR</b> BES Q08ZE-PSC20B-BV02	<b>BES01UM</b> BES Q08ZE-PSC20B-BP02	<b>BES01U4</b> BES Q08ZC-PSC30B-S49G		
<b>BES01UH</b> BES Q08ZE-POC20B-BV02	<b>BES01UE</b> BES Q08ZE-POC20B-BP02			
<b>BES01UA</b> BES Q08ZE-NSC20B-BV02	<b>BES01U7</b> BES Q08ZE-NSC20B-BP02			
10...30 V DC 2.5 V 75 V DC 200 mA Yes/Yes/Yes -25...+70 °C 3 kHz Yellow LED IP 67 CE, cULus	10...30 V DC 2.5 V 75 V DC 200 mA Yes/Yes/Yes -25...+70 °C 3 kHz Yellow LED IP 67 CE, cULus	10...30 V DC 2 V 75 V DC 200 mA Yes/Yes/Yes -25...+70 °C 1 kHz Yellow LED IP 67 CE <b>Long range</b> Brass-coated PBT M8 connector, 3-pin		
Cast zinc PBT 2 m PVC cable, 3x0.14 mm <sup>2</sup>	Cast zinc PBT 2 m PUR cable, 3x0.14 mm <sup>2</sup>			

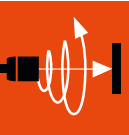

- Inductive Sensors
- Global DC 3-wire
- DC 3-/4-wire
- Cylinder Designs
- Block Designs
- DC 2-wire
- AC/DC 2-wire
- AC 2-wire
- Special Properties
- Analog Distance Measurement
- Accessories

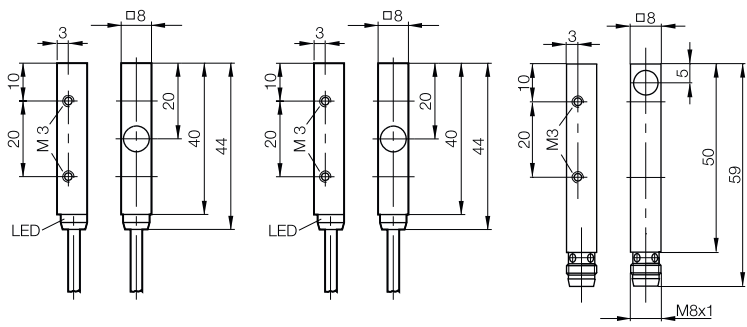

# DC 3-/4-wire Inductive Sensors

## Block designs, 8×16×4.7 mm R04, 8×16×4 mm R04



Model		8×18×4.7 mm R04	8×18×4.7 mm R04	8×16×4 mm R04
Installation type (observe instructions in the Basic Information chapter)		Flush	Flush	Flush
Rated switching distance $s_n$		<b>2 mm</b>	<b>2 mm</b>	<b>1.5 mm</b>
Assured switching distance $s_a$		0...1.6 mm	0...1.6 mm	0...1.2 mm
Switching distance marking		■ ■	■ ■	■
PNP, NO	<b>Ordering code</b>	<b>BES04F6</b>	<b>BES04FA</b>	<b>BES01YC</b>
	Part number	BES R04MC-PSC20B-EP02-106	BES R04MC-PSC20B-EP00,3-GS49-106	BES R04KC-PSC15B-EP00,2-GS26
PNP, NC	<b>Ordering code</b>	<b>BES04F5</b>	<b>BES04F8</b>	<b>BES01Y7</b>
	Part number	BES R04MC-POC20B-EP02-106	BES R04MC-POC20B-EP00,3-GS49-106	BES R04KC-POC15B-EP00,2-GS26
NPN, NO	<b>Ordering code</b>	<b>BES04F4</b>	<b>BES04F9</b>	
	Part number	BES R04MC-NSC20B-EP02-106	BES R04MC-NSC20B-EP00,3-GS49-106	
NPN, NC	<b>Ordering code</b>	<b>BES04F3</b>	<b>BES04F7</b>	<b>BES01WY</b>
	Part number	BES R04MC-NOC20B-EP02-106	BES R04MC-NOC20B-EP00,3-GS49-106	BES R04KC-NOC15B-EP00,2-GS26
Supply voltage $U_s$		10...30 V DC	10...30 V DC	10...30 V DC
Voltage drop $U_d$ at $I_o$ max.		2.5 V	2.5 V	1.5 V
Rated insulation voltage $U_i$		75 V DC	75 V DC	75 V DC
Rated operating current $I_o$		100 mA	100 mA	100 mA
Polarity reversal protected/transposition protected/short-circuit protected		Yes/Yes/Yes	Yes/Yes/Yes	Yes/Yes/Yes
Ambient temperature $T_a$		-25...70 °C	-25...70 °C	-25...+70 °C
Switching frequency $f$ max.		5 kHz	5 kHz	2.5 kHz
Output function indicator		Yellow LED	Yellow LED	Yellow LED
Degree of protection as per IEC 60529		IP 67	IP 67	IP 67
Approvals		CE, cULus	CE, cULus	CE, cULus
Material	Housing	Brass-coated	Brass-coated	PA 6 (fiberglass reinforced)
	Sensing surface	Ceramic	Ceramic	PA 6 (fiberglass reinforced)
Connection		2 m PUR cable, 3×0.1 mm <sup>2</sup>	0.3 m PUR cable with M8 connector, 3-pin	0.2 m PUR cable with M5 connector, 3-pin

Wiring diagrams, see page 958.  
The meaning of switching distance markings can be found on page 962.

**Additional cable lengths and PUR cable jacket material available on request**

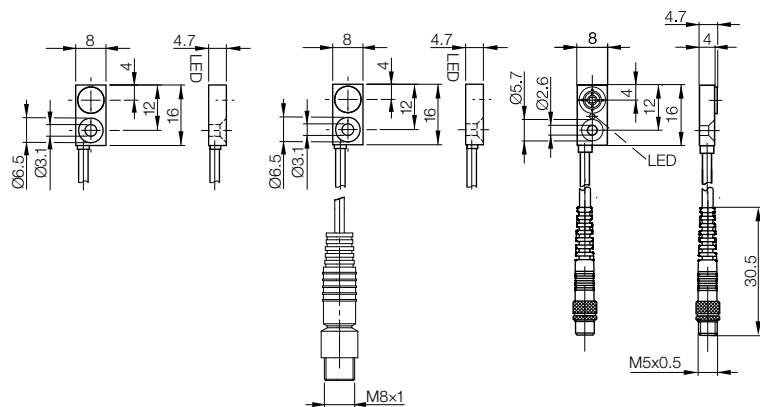

### Mounting bracket BES R04-MF-01

For BES R04... with  $s_n$  1.5 mm  
(please order separately)

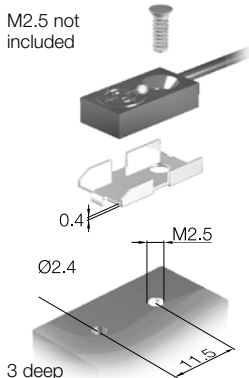

# DC 3-/4-wire Inductive Sensors

## Block designs, 8×16×4 mm R04



8×16×4 mm R04	8×16×4 mm R04	8×16×4 mm R04	8×16×4 mm R04	8×16×4 mm R04
Flush	Flush	Flush	Not flush	Not flush
<b>1.5 mm</b>	<b>1.5 mm</b>	<b>1.5 mm</b>	<b>2.5 mm</b>	<b>2.5 mm</b>
0...1.2 mm	0...1.2 mm	0...1.2 mm	0...2.2 mm	0...2.2 mm
■	■	■	■ ■	■ ■
<b>BES01YE</b>	<b>BES01YJ</b>	<b>BES01YF</b>	<b>BES01YM</b>	<b>BES01YN</b>
BES R04KC-PSC15B-EP00,3-GS49	BES R04KC-PSC15B-EV02	BES R04KC-PSC15B-EP02	BES R04KC-PSC25F-EP00,3-GS49	BES R04KC-PSC25F-EP02
<b>BES01Y8</b>	<b>BES03J1</b>		<b>BES0447</b>	
BES R04KC-POC15B-EP00,3-GS49	BES R04KC-POC15B-EV02		BES R04KC-POC25F-EP00,3-GS49	
	<b>BES01Y3</b>			
	BES R04KC-NSC15B-EV02			
	<b>BES01WZ</b>			
	BES R04KC-NOC15B-EV02			
10...30 V DC	10...30 V DC	10...30 V DC	10...30 V DC	10...30 V DC
1.5 V	1.8 V	2.5 V	2.5 V	2.5 V
75 V DC	75 V DC	75 V DC	75 V DC	75 V DC
100 mA	100 mA	100 mA	100 mA	100 mA
Yes/Yes/Yes	Yes/Yes/Yes	Yes/Yes/Yes	Yes/Yes/Yes	Yes/Yes/Yes
-25...+70 °C	-25...+70 °C	-25...+70 °C	-25...+70 °C	-25...+70 °C
2.5 kHz	2.5 kHz	2.5 kHz	3 kHz	3 kHz
Yellow LED	Yellow LED	Yellow LED	Yellow LED	Yellow LED
IP 67	IP 67	IP 67	IP 67	IP 67
CE, cULus	CE, cULus	CE, cULus	CE, cULus	CE, cULus
PA 6 (fiberglass reinforced)	PA 6 (fiberglass reinforced)	PA 6 (fiberglass reinforced)	PA 6 (fiberglass reinforced)	PA 6 (fiberglass reinforced)
PA 6 (fiberglass reinforced)	PA 6 (fiberglass reinforced)	PA 6 (fiberglass reinforced)	PA 6 (fiberglass reinforced)	PA 6 (fiberglass reinforced)
0.3 m PUR cable with M8 connector, 3-pin	2 m PVC cable, 3×0.09 mm <sup>2</sup>	2 m PUR cable, 3×0.1 mm <sup>2</sup>	0.3 m PUR cable with M8 connector, 3-pin	2 m PUR cable, 3×0.1 mm <sup>2</sup>

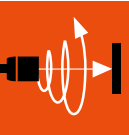

Inductive Sensors  
Global DC 3-wire  
DC 3-/4-wire  
Cylinder Designs  
Block Designs  
DC 2-wire  
AC/DC 2-wire  
AC 2-wire  
Special Properties  
Analog Distance Measurement  
Accessories

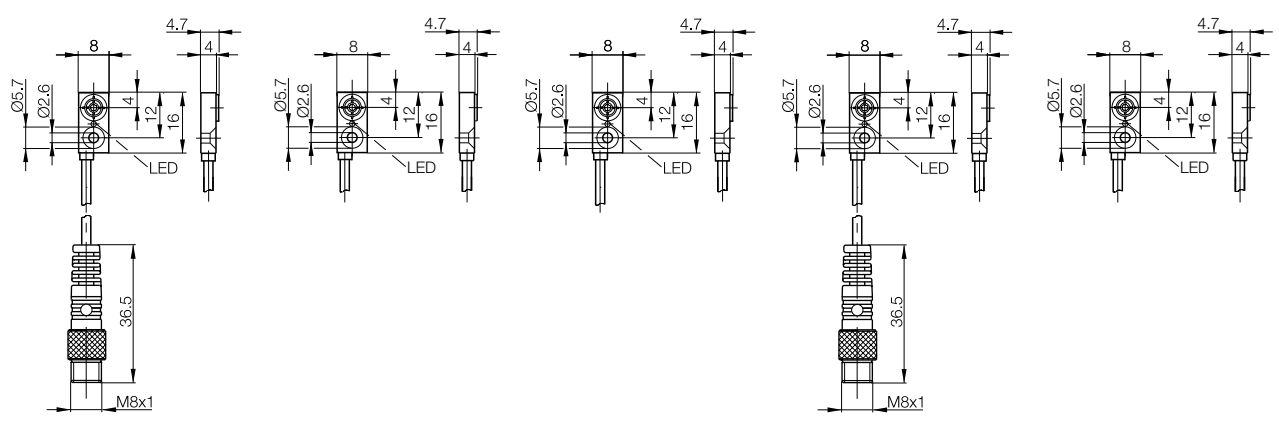

**Installation notice for BES R04... with s<sub>n</sub> 2.5 mm**

Aluminum: can be mounted completely flush  
Steel: all the way around with a 1.5 mm clear zone

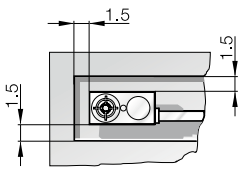

# DC 3-/4-wire Inductive Sensors

## Block designs, 10×30×6 mm R03



Model		<b>10×30×6 mm R03</b>	<b>10×30×6 mm R03</b>	<b>10×30×6 mm R03</b>
Installation type (observe instructions in the Basic Information chapter)		Flush	Flush	Flush
Rated switching distance $s_n$		<b>2 mm</b>	<b>3 mm</b>	<b>3 mm</b>
Assured switching distance $s_a$		0...1.6 mm	0...2.4 mm	0...2.4 mm
Switching distance marking		■	■	■
PNP, NO	<b>Ordering code</b>	<b>BES03J0</b>	<b>BES01WP</b>	<b>BES01WR</b>
	Part number	BES R03KC-PSC20B-EP02	BES R03KC-PSC30B-BP00,3-GS49	BES R03KC-PSC30B-EP02
NPN, NO	<b>Ordering code</b>			
	Part number			
Supply voltage $U_s$		10...30 V DC	10...30 V DC	10...30 V DC
Voltage drop $U_d$ at $I_e$ max.		1.5 V	1.8 V	2.5 V
Rated insulation voltage $U_i$		75 V DC	75 V DC	75 V DC
Rated operating current $I_e$		100 mA	100 mA	100 mA
Polarity reversal protected/transposition protected/short-circuit protected		No/No/Yes	Yes/Yes/Yes	Yes/Yes/Yes
Ambient temperature $T_a$		-25...+70 °C	-25...+70 °C	-25...+70 °C
Switching frequency $f$ max.		1 kHz	3 kHz	3 kHz
Output function indicator		Yellow LED	Yellow LED	Yellow LED
Degree of protection as per IEC 60529		IP 67	IP 67	IP 67
Approvals		CE, cULus	CE, cULus	CE, cULus
Material	Housing	PA 6	PA 6	PA 6
	Sensing surface	PA 6	PA 6	PA 6
Connection		2 m PUR cable, 3×0.14 mm <sup>2</sup>	0.3 m PUR cable with M8 connector, 3-pin	2 m cable TPU, 3×0.14 mm <sup>2</sup>

Wiring diagrams, see page 958.  
The meaning of switching distance markings can be found on page 962.

**Additional cable lengths and PUR cable jacket material available on request**

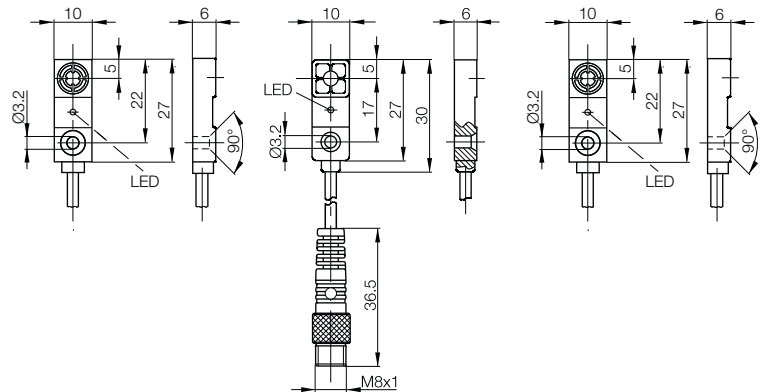



# DC 3-/4-wire Inductive Sensors

## Block designs, 10×30×6 mm R03, 30×20×10 mm



<b>10×30×6 mm R03</b> Not flush <b>3 mm</b> 0...2.4 mm ■	<b>10×30×6 mm R03</b> Not flush <b>3 mm</b> 0...2.4 mm ■		<b>30×20×10 mm</b> Flush <b>2 mm</b> 0...1.6 mm ■	
<b>BES02ZN</b> BES R03KC-PSC30F-BV00.2-GS49	<b>BES0397</b> BES R03KC-PSC30F-BV00.3-GS04		<b>BES033J</b> BES 516-300-S279	
			<b>BES033H</b> BES 516-300-S255	
10...30 V DC 1.5 V 75 V DC 100 mA No/No/Yes -25...+70 °C 500 Hz Yellow LED IP 67	10...30 V DC 1.5 V 75 V DC 100 mA No/No/Yes -25...+70 °C 500 Hz Yellow LED IP 67		10...30 V DC 0.5 V 75 V DC 50 mA Yes/No/No -25...+70 °C 1.5 kHz Yes/No IP 65	
PA 6 PA 6 0.2 m PVC cable with M8 connector, 3-pin	PA 6 PA 6 0.3 m PVC cable with M12 connector, 3-pin		Anodized GD-Al PBT 5 m PVC cable, 3×0.14 mm <sup>2</sup>	

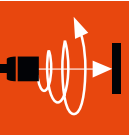

Inductive Sensors  
Global DC 3-wire  
DC 3-/4-wire  
Cylinder Designs  
**Block Designs**  
DC 2-wire  
AC/DC 2-wire  
AC 2-wire  
Special Properties  
Analog Distance Measurement  
Accessories

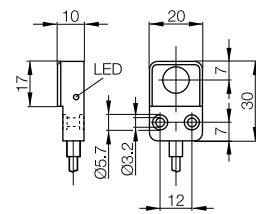
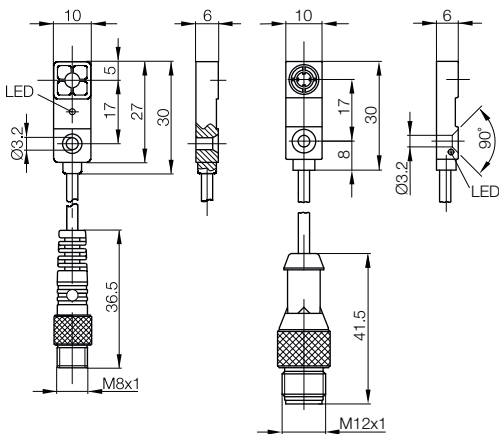

**Recommended short-circuit protection device:** Miniature fuse in accordance with IEC 60127-2 Sheet 1, ≤ 2 A (fast-acting). The fuse has to be in the load current line; the fuse may not be placed in the output line.

# DC 3-/4-wire Inductive Sensors

## Block designs, 16×30×10 mm



Model		16×30×10 mm	16×30×10 mm	16×30×10 mm
Installation type (observe instructions in the Basic Information chapter)		Flush	Flush	Flush
Rated switching distance $s_n$		<b>2 mm</b>	<b>2 mm</b>	<b>2 mm</b>
Assured switching distance $s_a$		0...1.6 mm	0...1.6 mm	0...1.6 mm
Switching distance marking		■	■	■
PNP, NO	<b>Ordering code</b>	<b>BES01N2</b>	<b>BES01N1</b>	<b>BES01NA</b>
	Part number	BES 517-398-N2-C	BES 517-398-N1-C	BES 517-398-NO-C-S49-00,2
PNP, NC	<b>Ordering code</b>	<b>BES01MK</b>	<b>BES01MJ</b>	
	Part number	BES 517-351-N2-C	BES 517-351-N1-C	
PNP, complementary	<b>Ordering code</b>			
	Part number			
NPN, NO	<b>Ordering code</b>	<b>BES01NE</b>	<b>BES01NC</b>	<b>BES01NM</b>
	Part number	BES 517-399-N2-C	BES 517-399-N1-C	BES 517-399-NO-C-S49-00,2
NPN, NC	<b>Ordering code</b>	<b>BES01MW</b>	<b>BES01MU</b>	
	Part number	BES 517-352-N2-C	BES 517-352-N1-C	
NPN, complementary	<b>Ordering code</b>			
	Part number			
Supply voltage $U_s$		10...30 V DC	10...30 V DC	10...30 V DC
Voltage drop $U_d$ at $I_e$ max.		2.5 V	2 V	2 V
Rated insulation voltage $U_i$		75 V DC	75 V DC	75 V DC
Rated operating current $I_e$		200 mA	200 mA	200 mA
Polarity reversal protected/transposition protected/short-circuit protected		Yes/Yes/Yes	Yes/Yes/Yes	Yes/Yes/Yes
Ambient temperature $T_a$		-25...+70 °C	-25...+70 °C	-25...+70 °C
Switching frequency $f$ max.		2.5 kHz	2.5 kHz	2.5 kHz
Output function indicator		Yellow LED	Yellow LED	Yellow LED
Degree of protection as per IEC 60529		Housing IP 65	Housing IP 65	IP 65
Approvals		CE	CE	CE
Material	Housing	PBT	PBT	PBT
	Sensing surface	PBT	PBT	PBT
Connection		DIN-46244- plug connector	DIN-46244- plug connector	0.2 m PUR cable with M8 connector, 3-pin

Wiring diagrams, see page 958.

The meaning of switching distance markings can be found on page 962.

**Additional cable lengths and PUR cable jacket material available on request**

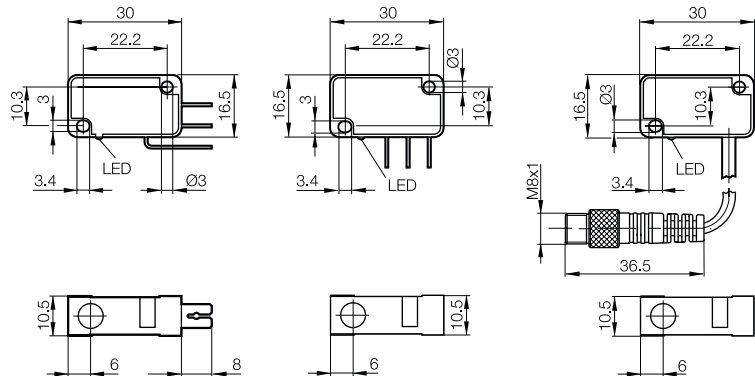

# DC 3-/4-wire Inductive Sensors

## Block designs, 16×30×10 mm R01, 20×32×8 mm

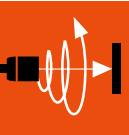

Inductive Sensors

Global DC 3-wire

DC 3-/4-wire

Cylinder Designs

Block Designs

DC 2-wire

AC/DC 2-wire

AC 2-wire

Special Properties

Analog Distance Measurement

Accessories

16×30×10 mm	20×32×8 mm R01	20×32×8 mm R01	20×32×8 mm R01
Flush	Flush	Flush	Flush
<b>2 mm</b>	<b>7 mm</b>	<b>7 mm</b>	<b>7 mm</b>
0...1.6 mm	0...5.6 mm	0...5.6 mm	0...5.6 mm
■	■	■	■
<b>BES01N4</b>	<b>BES01WF</b>	<b>BES01WE</b>	
BES 517-398-NO-C-02	BES R01ZC-PSC70B-BP00.3-GS49	BES R01ZC-PSC70B-BP00.2-GS49	
<b>BES01ML</b>			<b>BES01W2</b>
BES 517-351-NO-C-02			BES R01ZC-PAC70B-BP00.2-GS04
<b>BES01NF</b>		<b>BES01W1</b>	
BES 517-399-NO-C-02		BES R01ZC-NSC70B-BP00.2-GS49	
<b>BES01MY</b>			<b>BES01UZ</b>
BES 517-352-NO-C-02			BES R01ZC-NAC70B-BP00.2-GS04
10...30 V DC	10...30 V DC	10...30 V DC	10...30 V DC
2 V	2.5 V	2.5 V	2.5 V
75 V DC	75 V DC	75 V DC	75 V DC
200 mA	200 mA	200 mA	200 mA
Yes/Yes/Yes	Yes/Yes/Yes	Yes/Yes/Yes	Yes/Yes/Yes
-25...+70 °C	-25...+70 °C	-25...+70 °C	-25...+70 °C
2.5 kHz	150 Hz	150 Hz	150 Hz
Yellow LED	Yellow LED	Yellow LED	Yellow LED
IP 65	IP 67	IP 67	IP 67
CE	CE, cULus	CE, cULus	CE, cULus
PBT	Cast zinc	Cast zinc	Cast zinc
PBT	PA 12	PA 12	PA 12
2 m PVC cable, 3×0.14 mm <sup>2</sup>	0.3 m PUR cable with M8 connector, 3-pin	0.2 m PUR cable with M8 connector, 3-pin	0.2 m PVC cable with M12 connector, 4-pin

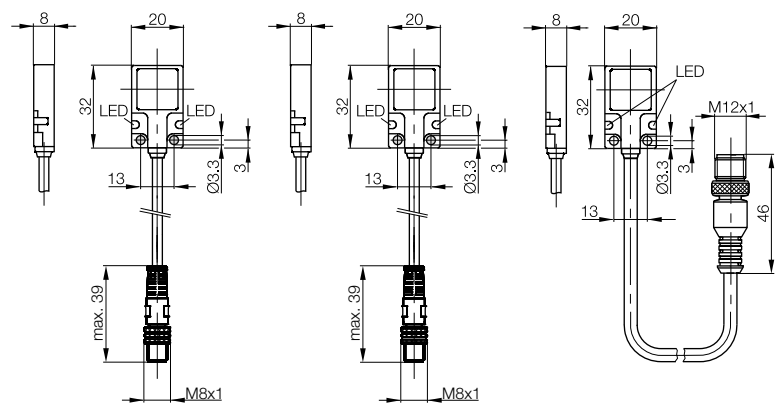
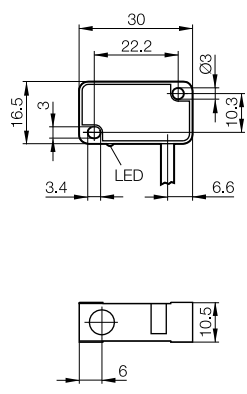

# DC 3-/4-wire Inductive Sensors

## Block designs, 20×50×10 mm



Model		20×50×10 mm	20×50×10 mm	20×50×10 mm
Installation type (observe instructions in the Basic Information chapter)		Flush	Flush	Flush
Rated switching distance $s_n$		5 mm	5 mm	5 mm
Assured switching distance $s_a$		0...4.1 mm	0...4.1 mm	0...4.1 mm
Switching distance marking		■	■	■
PNP, NO	<b>Ordering code</b>	<b>BES01FR</b>	<b>BES01FT</b>	<b>BES01FN</b>
	Part number	BES 516-347-M0-C-S49	BES 516-347-M0-C-S49-00,2	BES 516-347-M0-C-S4-00,2
PNP, complementary	<b>Ordering code</b>			<b>BES0153</b>
	Part number			BES 516-133-M0-C-S4-00,2
Supply voltage $U_s$		10...30 V DC	10...30 V DC	10...30 V DC
Voltage drop $U_d$ at $I_e$ max.		2.5 V	2.5 V	2.5 V
Rated insulation voltage $U_i$ (protection class)		75 V DC	75 V DC	75 V DC
Rated operating current $I_e$		200 mA	200 mA	200 mA
Polarity reversal protected/transposition protected/short-circuit protected		Yes/Yes/Yes	Yes/Yes/Yes	Yes/Yes/Yes
Ambient temperature $T_a$		-25...+70 °C	-25...+70 °C	-25...+70 °C
Switching frequency $f$ max.		500 Hz	500 Hz	500 Hz
Output function indicator		Yellow LED	Yellow LED	Yellow LED
Degree of protection as per IEC 60529		IP 67	IP 67	IP 67
Approvals		CE, cULus	CE, cULus	CE, cULus
Material	Housing	Cast aluminum	Cast aluminum	Cast aluminum
	Sensing surface	PBT	PBT	PBT
Connection		M8 connector, 3-pin	0.2 m PUR cable with M8 connector, 3-pin	0.2 m PUR cable with M12 connector, 4-pin

Wiring diagrams, see page 958.  
The meaning of switching distance markings can be found on page 962.

**Additional cable lengths and PUR cable jacket material available on request**

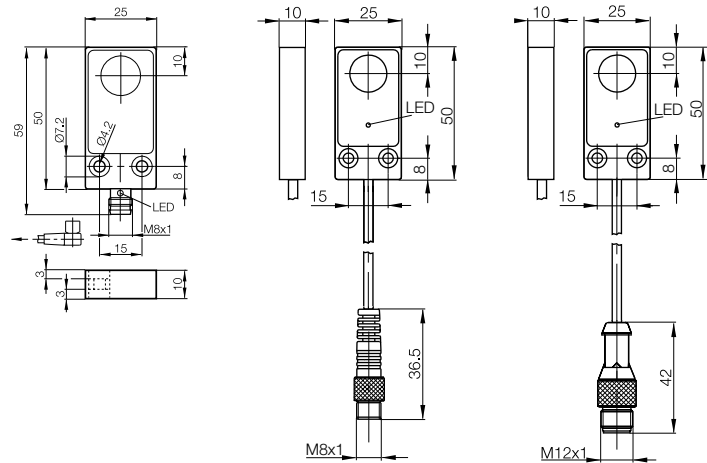



<b>20×50×10 mm</b>					
Flush					
<b>5 mm</b>					
0...4.1 mm					
■					
<b>BES01FH</b>					
BES 516-347-M0-C-02					
<b>BES0179</b>					
BES 516-133-M0-C-02					
10...30 V DC					
2.5 V					
75 V DC					
200 mA					
Yes/Yes/Yes					
-25...+70 °C					
500 Hz					
Yellow LED					
IP 67					
CE, cULus					
Cast aluminum					
PBT					
2 m PVC cable, 3×0.34 mm <sup>2</sup>					

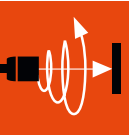

- Inductive Sensors
- Global DC 3-wire
- DC 3-/4-wire
- Cylinder Designs
- Block Designs**
- DC 2-wire
- AC/DC 2-wire
- AC 2-wire
- Special Properties
- Analog Distance Measurement
- Accessories

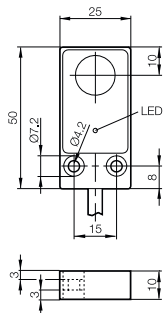

# DC 3-/4-wire Inductive Sensors

## Block designs, 26×40×12 mm R05



Model		26×40×12 mm R05	26×40×12 mm R05
Installation type (observe instructions in the Basic Information chapter)		Flush	Flush
Rated switching distance $s_n$		<b>2 mm</b>	<b>2 mm</b>
Assured switching distance $s_a$		0...1.6 mm	0...1.6 mm
Switching distance marking		■	■
PNP, NO	<b>Ordering code</b>	<b>BES01Z7</b>	<b>BES01Z3</b>
	Part number	BES R05KB-PSC20B-S49A	BES R05KB-PSC20B-BP00,3-GS49
PNP, NC	<b>Ordering code</b>		
	Part number		
NPN, NO	<b>Ordering code</b>		
	Part number		
NPN, NC	<b>Ordering code</b>		
	Part number		
Supply voltage $U_s$		10...30 V DC	10...30 V DC
Voltage drop $U_d$ at $I_o$ max.		2.5 V	2.5 V
Rated insulation voltage $U_i$ (protection class)		75 V DC	75 V DC
Rated operating current $I_o$		200 mA	200 mA
Polarity reversal protected/transposition protected/short-circuit protected		Yes/Yes/Yes	Yes/Yes/Yes
Ambient temperature $T_a$		-25...+70 °C	-25...+70 °C
Switching frequency $f$ max.		400 Hz	400 Hz
Output function indicator		Yellow LED	Yellow LED
Degree of protection as per IEC 60529		IP 67	IP 67
Approvals		CE, cULus	CE, cULus
Material	Housing	PA 12	PA 12
	Sensing surface	PA 12	PA 12
Connection		M8 connector, 3-pin	0.3 m PUR cable with M8 connector, 3-pin

Wiring diagrams, see page 958.  
The meaning of switching distance markings can be found on page 962.

**Additional cable lengths and PUR cable jacket material available on request**

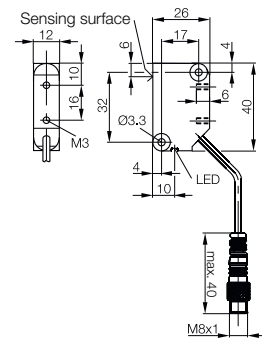
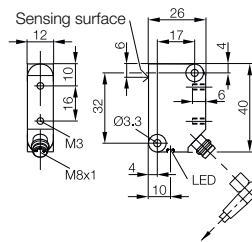

# DC 3-/4-wire Inductive Sensors

## Block designs, 26×40×12 mm R05



26×40×12 mm R05	26×40×12 mm R05	26×40×12 mm R05	26×40×12 mm R05
Flush	Flush	Flush	Flush
<b>2 mm</b>	<b>4 mm</b>	<b>4 mm</b>	<b>4 mm</b>
0...1.6 mm	0...3.2 mm	0...3.2 mm	0...3.2 mm
■	■	■	■
<b>BES01Z4</b>	<b>BES01ZE</b>	<b>BES01Z8</b>	<b>BES01ZA</b>
BES R05KB-PSC20B-EP02	BES R05KB-PSC40B-S49A	BES R05KB-PSC40B-EP00,3-GS04	BES R05KB-PSC40B-EV02
	<b>BES01Z2</b>		
	BES R05KB-POC40B-S49A		
	<b>BES01Z1</b>		
	BES R05KB-NSC40B-S49A		
			<b>BES01YW</b>
			BES R05KB-NOC40B-EV02
10...30 V DC	10...30 V DC	10...30 V DC	10...30 V DC
2.5 V	2.5 V	2.5 V	2.5 V
250 V AC (□)	75 V DC	250 V AC (□)	250 V AC (□)
200 mA	200 mA	200 mA	200 mA
Yes/Yes/Yes	Yes/Yes/Yes	Yes/Yes/Yes	Yes/Yes/Yes
-25...+70 °C	-25...+70 °C	-25...+70 °C	-25...+70 °C
400 Hz	400 Hz	400 Hz	400 Hz
Yellow LED	Yellow LED	Yellow LED	Yellow LED
IP 67	IP 67	IP 67	IP 67
CE, cULus	CE, cULus	CE, cULus	CE, cULus
PA 12	PA 12	PA 12	PA 12
PA 12	PA 12	PA 12	PA 12
2 m PUR cable, 3×0.34 mm <sup>2</sup>	M8 connector, 3-pin	0.3 m PUR cable with M12 connector, 4-pin	2 m PVC cable, 3×0.34 mm <sup>2</sup>

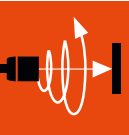

- Inductive Sensors
- Global DC 3-wire
- DC 3-/4-wire
- Cylinder Designs
- Block Designs**
- DC 2-wire
- AC/DC 2-wire
- AC 2-wire
- Special Properties
- Analog Distance Measurement
- Accessories

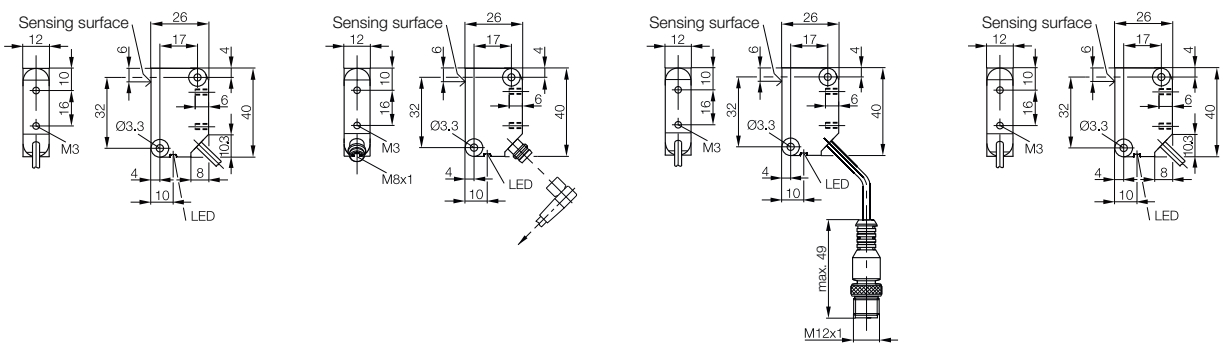

# DC 3-/4-wire Inductive Sensors

## Block designs, 42x48x22 mm



Model		<b>42x48x22 mm</b>	<b>42x48x22 mm</b>
Installation type (observe instructions in the Basic Information chapter)		Flush	Flush
Rated switching distance $s_n$		<b>5 mm</b>	<b>5 mm</b>
Assured switching distance $s_a$		0...4.1 mm	0...4.1 mm
Switching distance marking		■	■
PNP, NO	<b>Ordering code</b>	<b>BES01FC</b>	<b>BES01FF</b>
	Part number	BES 516-346-H2-Y	BES 516-346-H2-Y-S49
PNP, NC	<b>Ordering code</b>	<b>BES01EU</b>	
	Part number	BES 516-341-H2-Y	
PNP, complementary	<b>Ordering code</b>		
	Part number		
NPN, NO	<b>Ordering code</b>	<b>BES01ZK</b>	
	Part number	BES 516-344-H2-Y	
NPN, NC	<b>Ordering code</b>	<b>BES01ET</b>	
	Part number	BES 516-340-H2-Y	
Supply voltage $U_s$		10...30 V DC	10...30 V DC
Voltage drop $U_d$ at $I_o$ max.		3.5 V	3.5 V
Rated insulation voltage $U_i$		75 V DC	75 V DC
Rated operating current $I_o$		130 mA	130 mA
Polarity reversal protected/transposition protected/short-circuit protected		Yes/Yes/Yes	Yes/Yes/Yes
Ambient temperature $T_a$		-25...+70 °C	-25...+70 °C
Switching frequency $f$ max.		500 Hz	500 Hz
Output function indicator		Yellow LED	Yellow LED
Degree of protection as per IEC 60529		IP 67	IP 67
Approvals		CE	CE
Material	Housing	Cast aluminum	Cast aluminum
	Sensing surface	PA 12	PA 12
Connection		Screw terminals up to 2.5 mm <sup>2</sup>	M8 connector, 3-pin

Wiring diagrams, see page 958.  
The meaning of switching distance markings can be found on page 962.

**Additional cable lengths and PUR cable jacket material available on request**

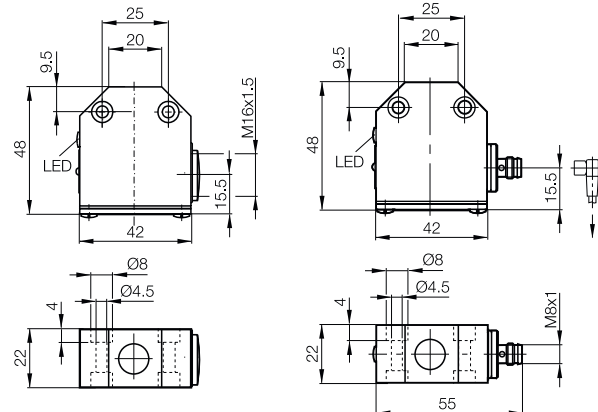



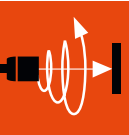

Inductive Sensors  
Global DC 3-wire  
DC 3-/4-wire  
Cylinder Designs  
Block Designs  
DC 2-wire  
AC/DC 2-wire  
AC 2-wire  
Special Properties  
Analog Distance Measurement  
Accessories

42×48×22 mm	74×60.5×28 mm
Flush	Flush
<b>5 mm</b>	<b>7 mm</b>
0...4.1 mm	0...5.7 mm
■	■
<b>BES01FE</b>	
BES 516-346-H2-Y-S4	
<b>BES01EW</b>	
BES 516-341-H2-Y-S4	
	<b>BES017M</b>
	BES 516-161-H3-L
10...30 V DC	10...30 V DC
3.5 V	1.5 V
75 V DC	75 V DC
130 mA	400 mA
Yes/Yes/Yes	Yes/No/No
-25...+70 °C	-25...+70 °C
500 Hz	300 Hz
Yellow LED	Yellow LED
IP 67	IP 67
CE	CE
Cast aluminum	Cast aluminum
PA 12	PA 12
M12 connector, 4-pin	Screw terminals up to 2.5 mm <sup>2</sup>

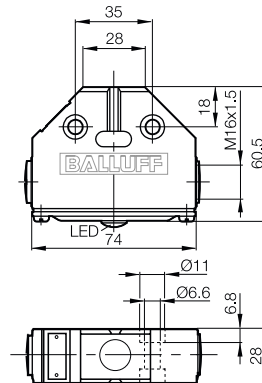
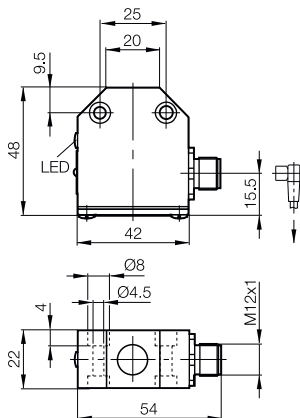

**Recommended short circuit protection equipment:**  
Miniature fuse in accordance with IEC60127-2 Sheet 1, ≤ 2 A (fast-acting). The fuse has to be in the load current; the fuse may not be placed in the output wiring.

# DC 3-/4-wire Inductive Sensors

## Block design, 40×40 mm Unicompat

### Unicompat

The Unicompat is a flexible sensor for versatile application in mechanical and systems engineering and wherever space is at a premium. The sensing surface is convertible. The connection can be rotated in all directions. With it, angle plugs are also positioned optimally at all time.

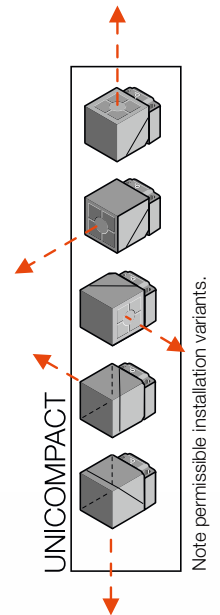

Compact sensor designs with large switching distances are required in material handling technology. In addition, the switching and operating state of the sensor must be able to be identified from far away.



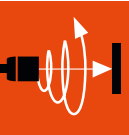

Inductive Sensors  
Global DC 3-wire  
DC 3-/4-wire  
Cylinder Designs  
**Block Designs**  
DC 2-wire  
AC/DC 2-wire  
AC 2-wire  
Special Properties  
Analog Distance Measurement  
Accessories

Model	40×40 mm Unicomact	40×40 mm Unicomact
Installation type (observe instructions in the Basic Information chapter)	Flush	Flush
Rated switching distance $s_n$	<b>20 mm</b>	<b>20 mm</b>
Assured switching distance $s_a$	0...16 mm	0...16 mm
Switching distance marking	■	■
PNP, NO	<b>Ordering code</b> <b>BES021W</b>	
Part number	BES Q40KFU-PSC20B-S04G	
PNP, complementary	<b>Ordering code</b> <b>BES0217</b>	<b>BES0218</b>
Part number	BES Q40KFU-PAC20B-S04G	BES Q40KFU-PAC20B-S04G-004
Supply voltage $U_s$	10...30 V DC	10...55 V DC
Voltage drop $U_d$ at $I_e$ max.	2.5 V	2.5 V
Rated insulation voltage $U_i$ (protection class)	250 V AC (□)	250 V AC (□)
Rated operating current $I_e$	200 mA	200 mA
Polarity reversal protected/transposition protected/short-circuit protected	Yes/Yes/Yes	Yes/Yes/Yes
Ambient temperature $T_a$	-25...+70 °C	-25...+70 °C
Switching frequency $f$ max.	50 Hz	50 Hz
Output function indicator	Yellow LED	Yellow LED
Degree of protection as per IEC 60529	IP 67	IP 67
Approvals	CE, cULus	CE
Material	Housing: PBT Sensing surface: PBT	Housing: PBT Sensing surface: PBT
Possible installation variations	Image 1...8	Image 1...8
Connection	M12 connector, 4-pin	M12 connector, 4-pin

Wiring diagrams, see page 958.  
The meaning of switching distance markings can be found on page 962.

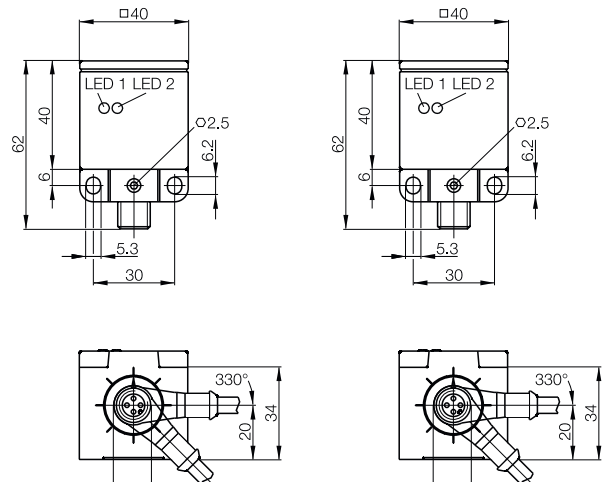

### Row mounting

Flush 80 mm  
Ø 120 mm non-flush

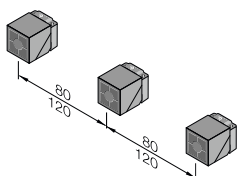

### Permissible installation options

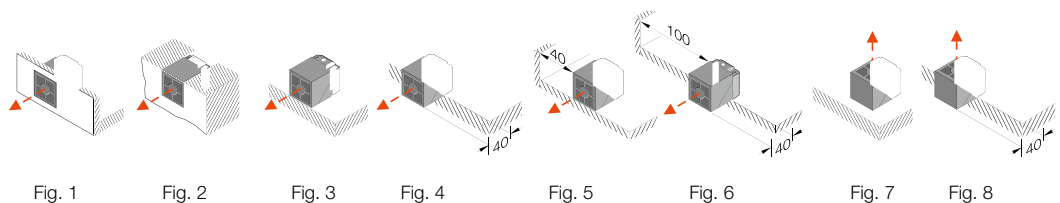

# DC 3-/4-wire Inductive Sensors

## Block design, 40×40 mm Unicompat



Model	<b>40×40 mm</b>	<b>40×40 mm</b>	
Installation type (observe instructions in the Basic Information chapter)	Flush	Not flush	
Rated switching distance $s_n$	<b>20 mm</b>	<b>25 mm</b>	
Assured switching distance $s_a$	0...16.2 mm	0...20 mm	
Switching distance marking	■	■	
PNP, NO	<b>Ordering code</b>	<b>BES0306</b>	
	Part number	BES Q40KFU-PSC20B-S04G-012	
PNP, complementary	<b>Ordering code</b>		
	Part number		
NPN, complementary	<b>Ordering code</b>		<b>BES022J</b>
	Part number		BES Q40KFU-NAC25F-S04G
Supply voltage $U_s$	10...30 V DC	10...30 V DC	
Voltage drop $U_d$ at $I_o$ max.	2.5 V	2.5 V	
Rated insulation voltage $U_i$ (protection class)	250 V AC (□)	250 V AC (□)	
Rated operating current $I_o$	200 mA	200 mA	
Polarity reversal protected/transposition protected/short-circuit protected	Yes/Yes/Yes	Yes/Yes/Yes	
Ambient temperature $T_a$	-25...+70 °C	-25...+70 °C	
Switching frequency $f$ max.	100 Hz	50 Hz	
Output function indicator	Yellow LED	Yellow LED	
Degree of protection as per IEC 60529	IP 67	IP 67	
Approvals	CE, cULus	CE, cULus	
Material	Housing PA	PBT	
	Sensing surface PA	PBT	
Possible installation variations	Image 1...8	Image 3...8	
Connection	M12 connector, 4-pin	M12 connector, 4-pin	

Wiring diagrams, see page 958.  
The meaning of switching distance markings can be found on page 962.

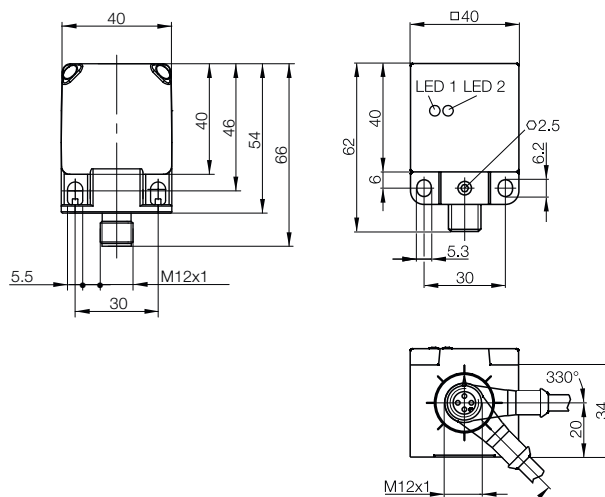

### Housing optimized for material handling technology

- Highly visible corner LEDs
- Sensor head can be mounted in five positions
- Connector outlet set to position within a 270° range





<b>40×40 mm</b> Not flush <b>25 mm</b> 0...20 mm ■	<b>40×40 mm</b> Not flush <b>30 mm</b> 0...24 mm ■	<b>40×40 mm</b> Not flush <b>40 mm</b> 0...32.4 mm ■■	
<b>BES0210</b> BES Q40KEU-PAH25F-S04G	<b>BES021Z</b> BES Q40KFU-PSC30F-S04G	<b>BES0308</b> BES Q40KFU-PSC40F-S04G-012	
	<b>BES021E</b> BES Q40KFU-PAC30F-S04G		
10...55 V DC 2.5 V 250 V AC (□) 200 mA Yes/Yes/Yes -25...+70 °C 50 Hz Yellow LED IP 67 CE PBT/Cast zinc PBT Image 3...8 M12 connector, 4-pin	10...30 V DC 2.5 V 250 V AC (□) 200 mA Yes/Yes/Yes -25...+70 °C 50 Hz Yellow LED IP 67 CE, cULus PBT Image 3...8 M12 connector, 4-pin	10...30 V DC 2.5 V 250 V AC (□) 200 mA Yes/Yes/Yes -25...+70 °C 60 Hz Yellow LED IP 67 CE, cULus PA Image 3...8 M12 connector, 4-pin	Inductive Sensors Global DC 3-wire DC 3-/4-wire Cylinder Designs Block Designs DC 2-wire AC/DC 2-wire AC 2-wire Special Properties Analog Distance Measurement Accessories

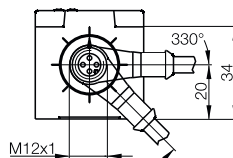
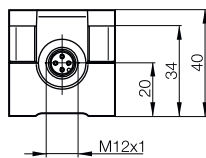
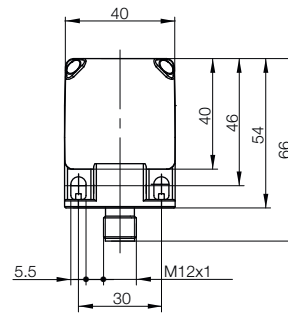
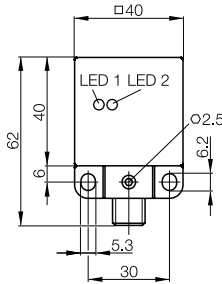
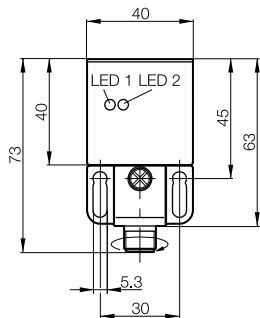

# DC 3-/4-wire Inductive Sensors

## Block design, 40×40 mm Unisensor

### The Unisensor – multiple uses

- The Unisensor is made up of three modular components: sensor head- including sensor head base), sensor body and sensor base.
- Easily removable pin contacts join sensor head- and sensor body, e.g. easy interchange of the modules without wiring.
- Sensor base with wiring terminals, self-lifting pressure plates and ample wiring room.
- Sensor head rotatable in five different positions for easy adaptation to any application (see installation drawings).
- PBT plastic housing.
- Mounting dimensions and values are based on DIN EN 60947-5-2
- LED for supply voltage and output function indicator
- Also available in special configuration for the automotive industry
- In the complementary version, output terminals 2 or 4 can be wired to configure the switch as normally closed (terminal 2) or normally open (terminal 4). By assigning both terminals, the complementary function can be used.

### Positioning the sensor head

- Loosen the two holding screws on the sensor head.
- Rotate the sensor head 180°.
- Tighten the holding screws.

### Rotate the sensor head.

- Loosen the holding screws.
- Rotate the sensor head (complete with sensor head base) into the desired position.
- Tighten the holding screws.
- Sensor head is protected against over-rotation.

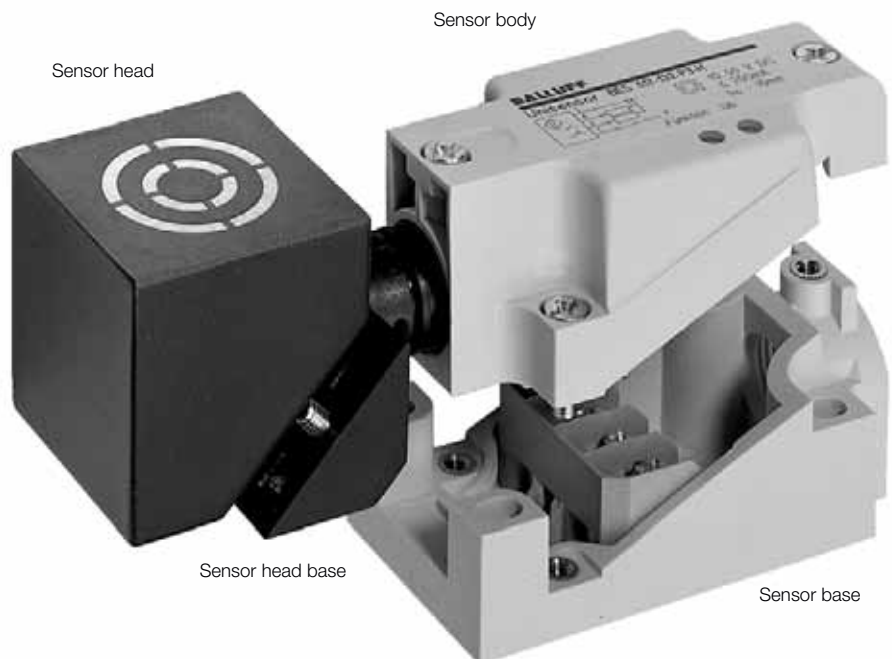
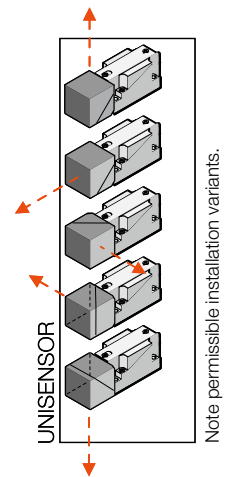

# DC 3-/4-wire Inductive Sensors

## Block design, 40×40 mm Unisensor

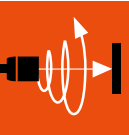

- Inductive Sensors
- Global DC 3-wire
- DC 3-/4-wire
- Cylinder Designs
- Block Designs**
- DC 2-wire
- AC/DC 2-wire
- AC 2-wire
- Special Properties
- Analog Distance Measurement
- Accessories

Model	40×40×120 mm Unisensor	40×40×120 mm Unisensor
Installation type (observe instructions in the Basic Information chapter)	Flush	Flush
Rated switching distance $s_n$	<b>15 mm</b>	<b>15 mm</b>
Assured switching distance $s_a$	0...12 mm	0...12 mm
Switching distance marking	■	■
PNP, complementary	<b>Ordering code</b> <b>BES0201</b>	<b>BES023F</b>
	Part number	BES 517-132-U3-H
Supply voltage $U_s$	10...55 V DC	10...55 V DC
Voltage drop $U_d$ at $I_e$ max.	2.5 V	2.5 V
Rated insulation voltage $U_i$ (protection class)	250 V AC (II)	250 V AC
Rated operating current $I_e$	200 mA	200 mA
Polarity reversal protected/transposition protected/short-circuit protected	Yes/Yes/Yes	Yes/Yes/Yes
Ambient temperature $T_a$	-25...+70 °C	-25...+70 °C
Switching frequency $f$ max.	100 Hz	100 Hz
Output function indicator	Yellow LED	Yellow LED
Degree of protection as per IEC 60529	IP 67	IP 67
Approvals	CE	CE
Material	Housing: PBT	PBT
	Sensing surface: PBT	PBT
Possible installation variations	Image 1...5	Image 1...5
Connection	Screw terminal, metric cable gland	Screw terminal, cable gland NPT

Wiring diagrams, see page 958.  
The meaning of switching distance markings can be found on page 962.

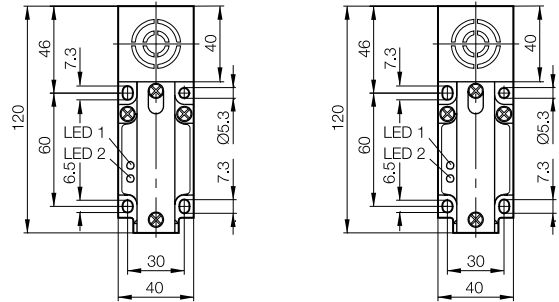

### Row mounting

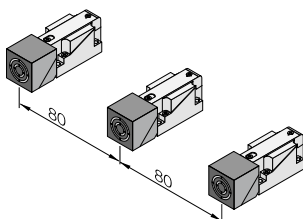

### Installation variations

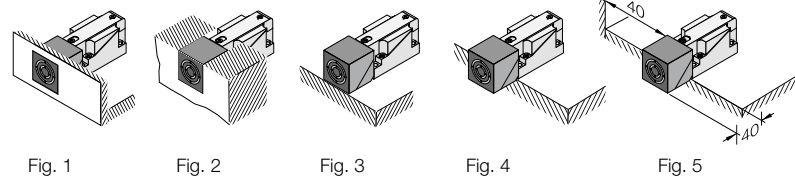



# DC 3-/4-wire Inductive Sensors

## Block design, 40x40 mm Unisensor



Model	40x40x120 mm Unisensor	40x40x120 mm Unisensor
Installation type (observe instructions in the Basic Information chapter)	Flush	Flush
Rated switching distance $s_n$	<b>15 mm</b>	<b>15 mm</b>
Assured switching distance $s_a$	0...12 mm	0...12 mm
Switching distance marking	■	■
PNP, complementary	<b>Ordering code</b> Part number	<b>BES0202</b> BES 517-132-M3-H-S4
NPN, complementary	<b>Ordering code</b> Part number	<b>BES020H</b> BES 517-134-M3-H-S4
Supply voltage $U_s$	10...55 V DC	10...55 V DC
Voltage drop $U_d$ at $I_e$ max.	2.5 V	2.5 V
Rated insulation voltage $U_i$ (protection class)	250 V AC (II)	250 V AC
Rated operating current $I_e$	200 mA	200 mA
Polarity reversal protected/transposition protected/short-circuit protected	Yes/Yes/Yes	Yes/Yes/Yes
Ambient temperature $T_a$	-25...+70 °C	-25...+70 °C
Switching frequency $f$ max.	100 Hz	100 Hz
Output function indicator	Yellow LED	Yellow LED
Degree of protection as per IEC 60529	IP 67	IP 67
Approvals	CE, cULus	CE
Material	Housing: PBT Sensing surface: PBT	PBT PBT
Possible installation variations	Image 1...5	Image 1...5
Connection	M12 connector, 4-pin	7/8" 16UN plug connector, 5-pin

Wiring diagrams, see page 958.  
The meaning of switching distance markings can be found on page 962.

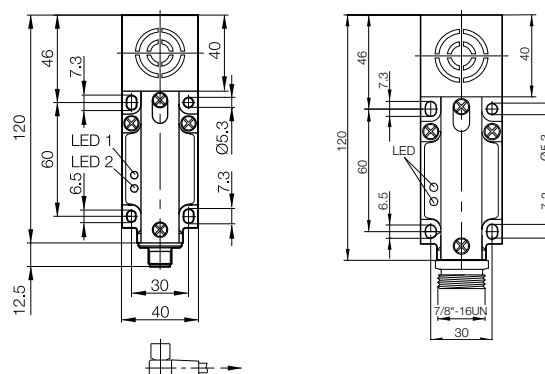



# DC 3-/4-wire Inductive Sensors

## Block design, 40×40 mm Unisensor

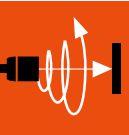
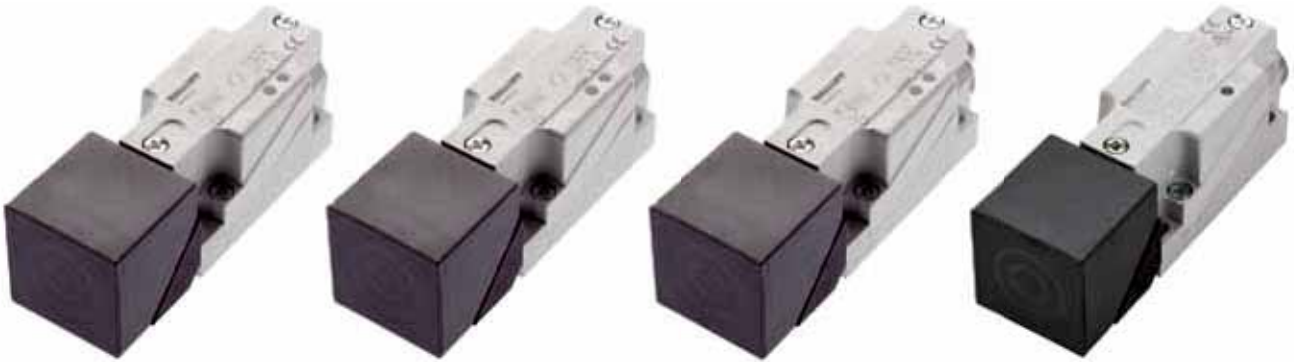

Inductive Sensors

Global DC 3-wire

DC 3-/4-wire

Cylinder Designs

Block Designs

DC 2-wire

AC/DC 2-wire

AC 2-wire

Special Properties

Analog Distance Measurement

Accessories

40×40×120 mm Unisensor	40×40×120 mm Unisensor	40×40×120 mm Unisensor	40×40×120 mm Unisensor
Flush	Flush	Flush	Flush
<b>20 mm</b>	<b>20 mm</b>	<b>20 mm</b>	<b>20 mm</b>
0...16 mm	0...16 mm	0...16 mm	0...16 mm
■	■	■	■
<b>BES0209</b>	<b>BES023L</b>	<b>BES020A</b>	
BES 517-132-M6-H	BES 517-132-U6-H	BES 517-132-M6-H-S4	
<b>BES020M</b>		<b>BES020N</b>	<b>BES020P</b>
BES 517-134-M6-H		BES 517-134-M6-H-S4	BES 517-134-M6-H-S5
10...55 V DC	10...55 V DC	10...55 V DC	10...55 V DC
2.5 V	2.5 V	2.5 V	2.5 V
250 V AC (□)	250 V AC (□)	250 V AC (□)	250 V AC (□)
200 mA	200 mA	200 mA	200 mA
Yes/Yes/Yes	Yes/Yes/Yes	Yes/Yes/Yes	Yes/Yes/Yes
-25...+70 °C	-25...+70 °C	-25...+70 °C	-25...+70 °C
50 Hz	50 Hz	50 Hz	50 Hz
Yellow LED	Yellow LED	Yellow LED	Yellow LED
IP 67	IP 67	IP 67	IP 67
CE	CE	CE	CE
PBT	PBT/aluminum	PBT	PBT
PBT	PBT	PBT	PBT
Image 1...5	Image 1...5	Image 1...5	Image 1...5
Screw terminal, metric cable gland	Screw terminal, cable gland NPT	M12 connector, 4-pin	7/8" 16UN plug connector, 5-pin

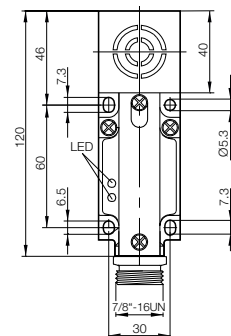
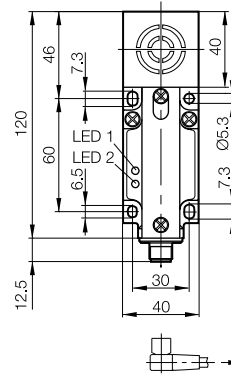
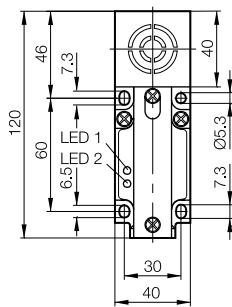
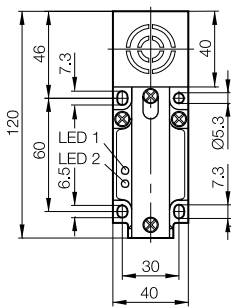

# DC 3-/4-wire Inductive Sensors

## Block design, 40x40 mm Unisensor



Model		40x40x120 mm Unisensor	40x40x120 mm Unisensor
Installation type (observe instructions in the Basic Information chapter)		Not flush	Not flush
Rated switching distance $s_n$		<b>20 mm</b>	<b>20 mm</b>
Assured switching distance $s_a$		0...16 mm	0...16 mm
Switching distance marking		■	■
PNP, NO	<b>Ordering code</b>		
	Part number		
PNP, complementary	<b>Ordering code</b>	<b>BES0204</b>	<b>BES0205</b>
	Part number	BES 517-132-M4-H	BES 517-132-M4-H-S4
NPN, complementary	<b>Ordering code</b>	<b>BES020J</b>	
	Part number	BES 517-134-M4-H	
Supply voltage $U_s$		10...55 V DC	10...55 V DC
Voltage drop $U_d$ at $I_e$ max.		2.5 V	2.5 V
Rated insulation voltage $U_i$ (protection class)		250 V AC (□)	250 V AC (□)
Rated operating current $I_e$		200 mA	200 mA
Polarity reversal protected/transposition protected/short-circuit protected		Yes/Yes/Yes	Yes/Yes/Yes
Ambient temperature $T_a$		-25...+70 °C	-25...+70 °C
Switching frequency $f$ max.		100 Hz	100 Hz
Output function indicator		Yellow LED	Yellow LED
Degree of protection as per IEC 60529		IP 67	IP 67
Approvals		CE	CE
Material	Housing	PBT	PBT
	Sensing surface	PBT	PBT
Possible installation variations		Image 3...5	Image 3...5
Connection		Screw terminal, metric cable gland	M12 connector, 4-pin

Wiring diagrams, see page 958.  
The meaning of switching distance markings can be found on page 962.

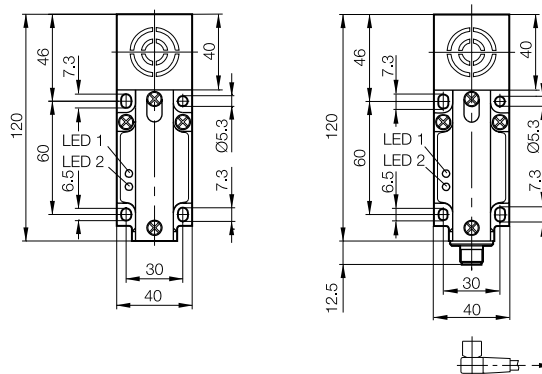

# DC 3-/4-wire Inductive Sensors

## Block design, 40×40 mm Unisensor



40×40×120 mm Unisensor	40×40×120 mm Unisensor	40×40×120 mm Unisensor	
Not flush	Not flush	Not flush	
<b>25 mm</b>	<b>25 mm</b>	<b>25 mm</b>	
0...20 mm	0...20 mm	0...20 mm	
■	■	■	
<b>BES0235</b>	<b>BES0236</b>		
BES 517-385-MV-C	BES 517-385-V-C-S4		
		<b>BES0312</b>	
		BES 517-134-U4-H-S5	
10...30 V DC	10...30 V DC	10...55 V DC	
3.5 V	3.5 V	2.5 V	
250 V AC (□)	250 V AC (□)	250 V AC (□)	
200 mA	200 mA	200 mA	
Yes/Yes/Yes	Yes/Yes/Yes	Yes/Yes/Yes	
-25...+70 °C	-25...+70 °C	-25...+70 °C	
50 Hz	50 Hz	100 Hz	
Yellow LED	Yellow LED	Yellow LED	
IP 67	IP 67	IP 67	
CE	CE	CE, cULus	
PBT	PBT	PBT	
PBT	PBT	PBT	
Image 3...5	Image 3...5	Image 3...5	
Screw terminal, metric cable gland	M12 connector, 4-pin	7/8" 16UN plug connector, 5-pin	

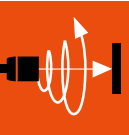

- Inductive Sensors
- Global DC 3-wire
- DC 3-/4-wire
- Cylinder Designs
- Block Designs
- DC 2-wire
- AC/DC 2-wire
- AC 2-wire
- Special Properties
- Analog Distance Measurement
- Accessories

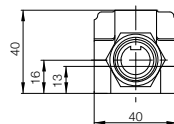
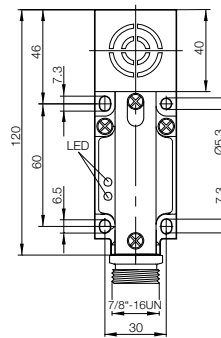
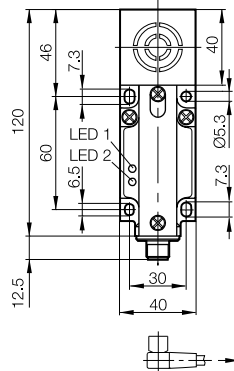
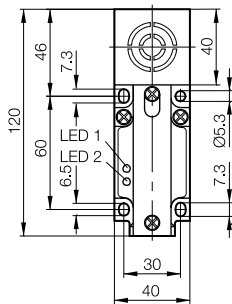

# DC 3-/4-wire Inductive Sensors

## Block design, 40x40 mm Unisensor



Model		40x40x120 mm Unisensor	40x40x120 mm Unisensor
Installation type (observe instructions in the Basic Information chapter)		Not flush	Not flush
Rated switching distance $s_n$		<b>30 mm</b>	<b>30 mm</b>
Assured switching distance $s_a$		0...24 mm	0...24 mm
Switching distance marking		■	■
PNP, NO	<b>Ordering code</b>	<b>BES0206</b>	
	Part number	BES 517-132-M5-H	
PNP, complementary	<b>Ordering code</b>		
	Part number		
NPN, complementary	<b>Ordering code</b>	<b>BES020K</b>	<b>BES023N</b>
	Part number	BES 517-134-M5-H	BES 517-134-U5-H
Supply voltage $U_s$		10...55 V DC	10...55 V DC
Voltage drop $U_d$ at $I_e$ max.		2.5 V	2.5 V
Rated insulation voltage $U_i$ (protection class)		250 V AC (□)	250 V AC (□)
Rated operating current $I_e$		200 mA	200 mA
Polarity reversal protected/transposition protected/short-circuit protected		Yes/Yes/Yes	Yes/Yes/Yes
Ambient temperature $T_a$		-25...+70 °C	-25...+70 °C
Switching frequency $f$ max.		60 Hz	60 Hz
Output function indicator		Yellow LED	Yellow LED
Degree of protection as per IEC 60529		IP 67	IP 67
Approvals		CE	CE
Material	Housing	PBT	PBT/aluminum
	Sensing surface	PBT	PBT
Possible installation variations		Image 3...5	Image 3...5
Connection		Screw terminal, metric cable gland	Screw terminal, cable gland NPT

Wiring diagrams, see page 958.  
The meaning of switching distance markings can be found on page 962.

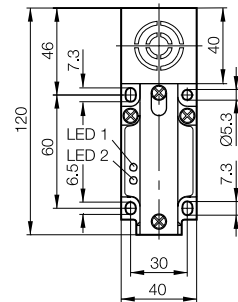
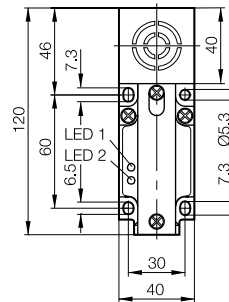

# DC 3-/4-wire Inductive Sensors

## Block design, 40×40 mm Unisensor

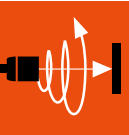

Inductive Sensors  
Global DC 3-wire  
DC 3-/4-wire  
Cylinder Designs  
**Block Designs**  
DC 2-wire  
AC/DC 2-wire  
AC 2-wire  
Special Properties  
Analog Distance Measurement  
Accessories

40×40×120 mm Unisensor	40×40×120 mm Unisensor	40×40×120 mm Unisensor	40×40×120 mm Unisensor
Not flush	Not flush	Not flush	Not flush
<b>30 mm</b>	<b>40 mm</b>	<b>40 mm</b>	<b>40 mm</b>
0...24 mm	0...32 mm	0...32 mm	0...32 mm
■	■	■	■
<b>BES0207</b>	<b>BES020C</b>	<b>BES023M</b>	<b>BES020E</b>
BES 517-132-M5-H-S4	BES 517-132-M7-H	BES 517-132-U7-H	BES 517-132-M7-H-S4
10...55 V DC	10...55 V DC	10...55 V DC	10...55 V DC
2.5 V	2.5 V	2.5 V	2.5 V
250 V AC (□)	250 V AC (□)	250 V AC (□)	250 V AC (□)
200 mA	200 mA	200 mA	200 mA
Yes/Yes/Yes	Yes/Yes/Yes	Yes/Yes/Yes	Yes/Yes/Yes
-25...+70 °C	-25...+70 °C	-25...+70 °C	-25...+70 °C
60 Hz	50 Hz	50 Hz	50 Hz
Yellow LED	Yellow LED	Yellow LED	Yellow LED
IP 67	IP 67	IP 67	IP 67
CE	CE	CE	CE
PBT	PBT	PBT/aluminum	PBT
PBT	PBT	PBT	PBT
Image 3...5	Image 3...5	Image 3...5	Image 3...5
M12 connector, 4-pin	Screw terminal, metric cable gland	Screw terminal, cable gland NPT	M12 connector, 4-pin

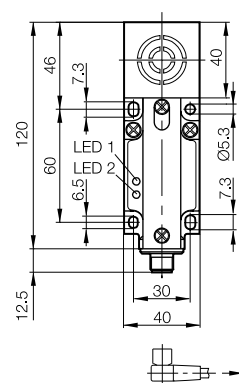
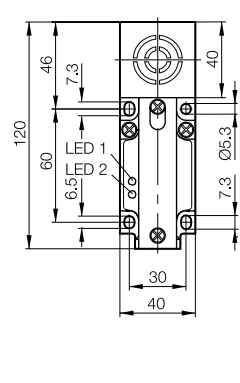
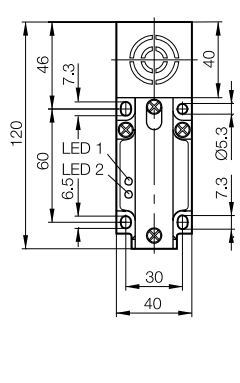
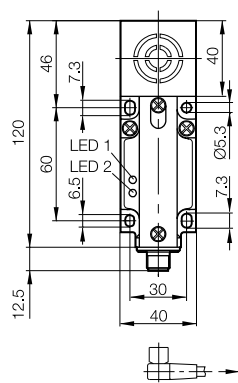

# DC 3-/4-wire Inductive Sensors

## Block design, 80×80 mm Maxisensor

### Flush mount

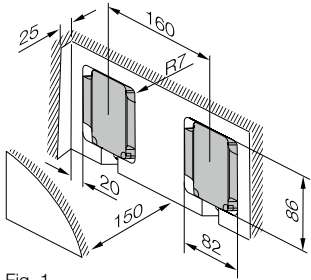

Fig. 1

### Non-flush mount

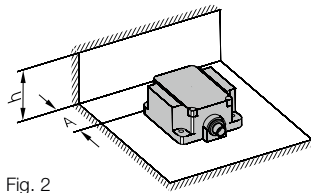

Fig. 2

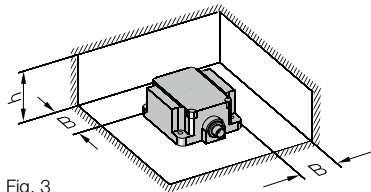

Fig. 3

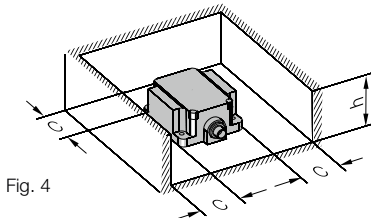

Fig. 4

### Minimum distances with steel

h	A	B	C
40 mm	70 mm	80 mm	90 mm
70 mm	80 mm	90 mm	100 mm

### Minimum distances with aluminum

h	A	B	C
40 mm	0 mm	10 mm	10 mm
70 mm	10 mm	20 mm	20 mm

The change of the real switching distance  $s_r$  is  $\leq 10\%$  with these installation dimensions.

### Mounting in steel

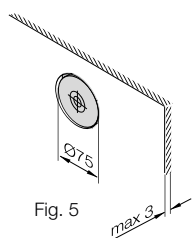

Fig. 5

### Mounting in non-ferrous metals

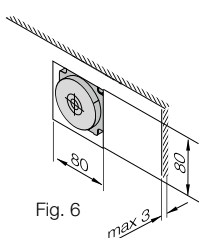

Fig. 6

### Mounting in steel/non-ferrous metals

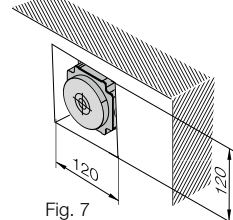

Fig. 7

### Mounting on steel/non-ferrous metals

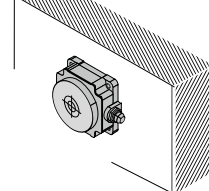
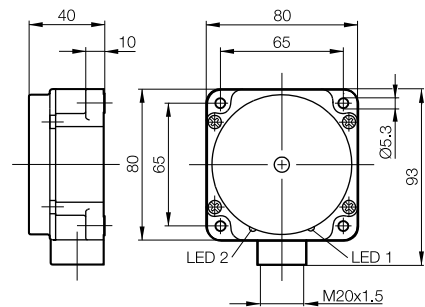

Fig. 8



Model	80×80×40 mm Maxisensor	
Installation type (observe instructions in the Basic Information chapter)	Flush	
Rated switching distance $s_n$	40 mm	
Assured switching distance $s_a$	0...32 mm	
Switching distance marking	■	
PNP, NO	<b>Ordering code</b>	
	Part number	
PNP, complementary	<b>Ordering code</b>	BES023P
	Part number	BES 517-139-M4-H
NPN, complementary	<b>Ordering code</b>	
	Part number	
Supply voltage $U_s$	10...55 V DC	
Voltage drop $U_d$ at $I_o$ max.	2.5 V	
Rated insulation voltage $U_i$ (protection class)	250 V AC (□)	
Rated operating current $I_o$	200 mA	
Polarity reversal protected/transposition protected/short-circuit protected	Yes/Yes/Yes	
Ambient temperature $T_a$	-15...+70 °C	
Switching frequency $f$ max.	50 Hz	
Output function indicator	Yellow LED	
Degree of protection as per IEC 60529	IP 67	
Approvals	CE	
Material	Housing	PBT
	Sensing surface	PBT
Possible installation variations	Image 5...8	
Connection	Screw terminal, metric cable gland	

Wiring diagrams, see page 958.  
Switching distance markings can be found on page 962.



# DC 3-/4-wire Inductive Sensors

## Block design, 80×80 mm Maxisensor



80×80×40 mm Maxisensor	80×84×40 mm Maxisensor	80×80×40 mm Maxisensor
Flush	Flush	Flush
<b>40 mm</b>	<b>40 mm</b>	<b>40 mm</b>
0...32 mm	0...32 mm	0...32 mm
■	■	■
	<b>BES0227</b>	
	BES Q80KA-PSH40B-S04Q	
	<b>BES0225</b>	
	BES Q80KA-PAH40B-S04Q	
<b>BES020R</b>		<b>BES020T</b>
BES 517-140-M4-H		BES 517-140-M4-H-S4
10...55 V DC	10...55 V DC	10...55 V DC
2.5 V	2.5 V	2.5 V
250 V AC (□)	250 V AC (□)	250 V AC (□)
200 mA	200 mA	200 mA
Yes/Yes/Yes	Yes/Yes/Yes	Yes/Yes/Yes
-25...+70 °C	-25...+70 °C	-25...+70 °C
50 Hz	50 Hz	50 Hz
Yellow LED	Yellow LED	Yellow LED
IP 67	IP 67	IP 67
CE	CE	CE
PBT	PBT	PBT
PBT	PBT	PBT
Image 5...8	Fig. 1	Image 5...8
Screw terminal, metric cable gland	M12 connector, 4-pin	M12 connector, 4-pin

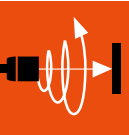

Inductive Sensors

Global DC 3-wire

DC 3-/4-wire

Cylinder Designs

Block Designs

DC 2-wire

AC/DC 2-wire

AC 2-wire

Special Properties

Analog Distance Measurement

Accessories

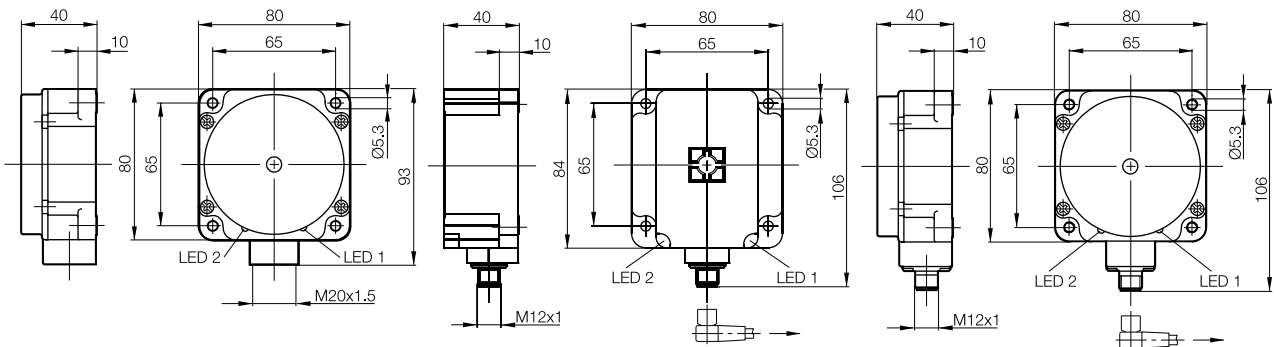

# DC 3-/4-wire Inductive Sensors

## Block design, 80×80 mm Maxisensor



Model	<b>80×92×40 mm Maxisensor</b>		<b>80×80×40 mm Maxisensor</b>
Installation type (observe instructions in the Basic Information chapter)	Flush		Not flush
Rated switching distance $s_n$	<b>50 mm</b>		<b>50 mm</b>
Assured switching distance $s_a$	0...40.5 mm		0...40 mm
Switching distance marking	■		■
PNP, NO	<b>Ordering code</b>		
	Part number		
PNP, complementary	<b>Ordering code</b>	<b>BES030C</b>	<b>BES023R</b>
	Part number	BES Q80KA-PAC50B-S04Q-U	BES 517-139-M5-H
NPN, complementary	<b>Ordering code</b>		<b>BES020U</b>
	Part number		BES 517-140-M5-H
Supply voltage $U_s$	10...36 V DC		10...55 V DC
Voltage drop $U_d$ at $I_e$ max.	2.5 V		2.5 V
Rated insulation voltage $U_i$ (protection class)	250 V AC (□)		250 V AC (□)
Rated operating current $I_e$	250 mA		200 mA
Polarity reversal protected/transposition protected/short-circuit protected	Yes/Yes/Yes		Yes/Yes/Yes
Ambient temperature $T_a$	-25...70 °C		-25...70 °C
Switching frequency $f$ max.	70 Hz		100 Hz
Output function indicator	Yellow LED		Yellow LED
Degree of protection as per IEC 60529	IP 67		IP 67
Approvals	CE, cULus		CE
Material	Housing	PPE	PBT
	Sensing surface	PPE	PBT
Possible installation variations			Image 7, 8
Connection	M12 connector, 4-pin		Screw terminal, metric cable gland

Wiring diagrams, see page 958.  
Switching distance markings can be found on page 962.

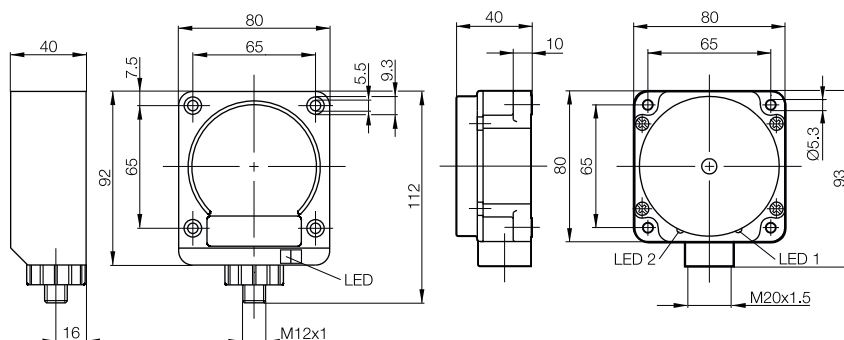



# DC 3-/4-wire Inductive Sensors

## Block design, 80×80 mm Maxisensor



80×80×40 mm Maxisensor	80×80×40 mm Maxisensor	80×84×40 mm Maxisensor
Not flush	Not flush	Not flush
<b>50 mm</b>	<b>50 mm</b>	<b>50 mm</b>
0...40 mm	0...40 mm	0...40 mm
■	■	■
	<b>BES023W</b>	<b>BES0228</b>
	BES 517-139-U5-H-S4	BES Q80KA-PSH50F-S04Q
		<b>BES0226</b>
		BES Q80KA-PAH50F-S04Q
<b>BES020W</b>		
BES 517-140-M5-H-S4		
10...55 V DC	10...55 V DC	10...55 V DC
2.5 V	2.5 V	2.5 V
250 V AC (□)	250 V AC (□)	250 V AC (□)
200 mA	200 mA	200 mA
Yes/Yes/Yes	Yes/Yes/Yes	Yes/Yes/Yes
-25...70 °C	-25...70 °C	-25...+70 °C
100 Hz	100 Hz	50 Hz
Yellow LED	Yellow LED	Yellow LED
IP 67	IP 67	IP 67
CE	CE, cULus	CE
PBT	PBT	PBT
PBT	PBT	PBT
Image 7, 8	Image 7, 8	Image 2...4
M12 connector, 4-pin	M12 connector, 4-pin	M12 connector, 4-pin

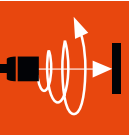

Inductive Sensors

Global DC 3-wire

DC 3-/4-wire

Cylinder Designs

Block Designs

DC 2-wire

AC/DC 2-wire

AC 2-wire

Special Properties

Analog Distance Measurement

Accessories

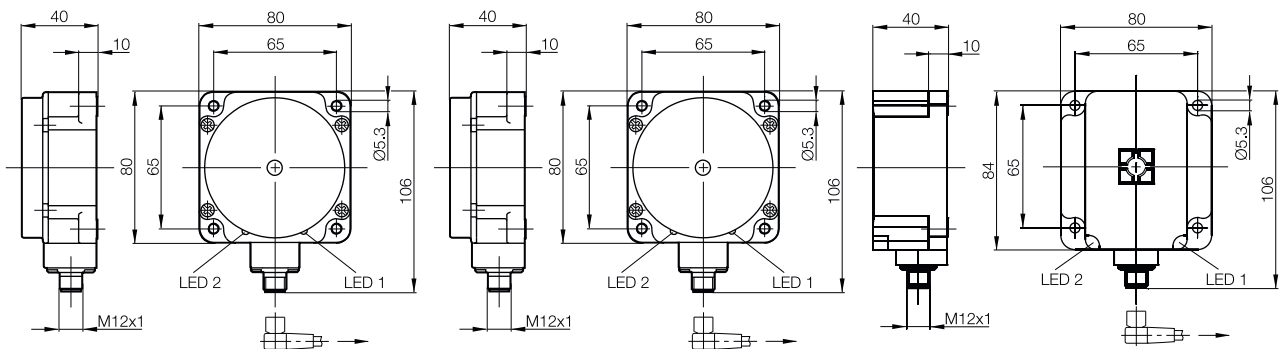

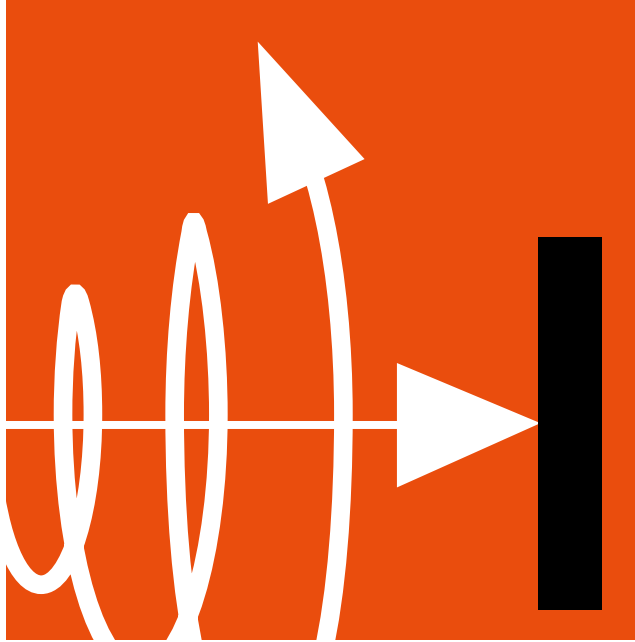

# Inductive Sensors

## DC 2-wire Inductive Sensors

Our **standard line of 2-wire DC versions**. This extensive line includes sensors from M8 to M30 as well as block designs for practically every application in automation.



**Cylinder Designs**

M8×1	571
M12×1	574
M18×1	576
M30×1.5	579

**Block Designs**

20×32×8 mm (R01)	582
26×26×26 mm (Z03)	583
40×66×40 mm (Unicompact)	584
40×121×40 mm (Unisensor)	585
80×92×40 mm (Maxisensor)	586

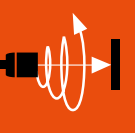

Basic information and definitions can be found on **page 934**.

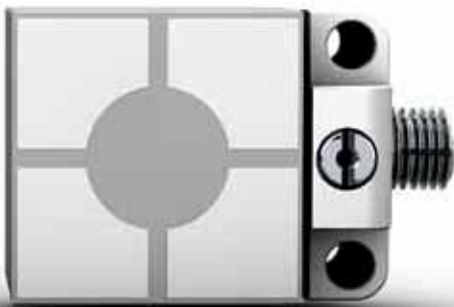

# DC 2-wire Inductive Sensors

**DC 2-wire sensors can be used universally:** They can be used in conjunction with most PNP or NPN controllers. Use of these sensors enables a reduction in the number of inventoried part numbers. Suitability of the 2-wire sensors for the respective PNP or NPN controller should be tested in advance.



## Global: The complete series of standard sensors

Inductive standard sensors are mostly available ex warehouse, can be used around the world and meet worldwide standards. They offer an optimal price/performance ratio.

- Short and mid-size designs Ø 6.5 mm to M30×1.5
- Shielded and unshielded designs
- Cable and connector versions
- Standard and extended switching distance



Model	
Installation type (observe instructions in the Basic Information chapter)	
Rated switching distance $s_n$	
Assured switching distance $s_a$	
Switching distance marking	
Polarized, NO	<b>Ordering code</b>
	Part number
Polarized, NC	<b>Ordering code</b>
	Part number
Non-polarized, NO	<b>Ordering code</b>
	Part number
Non-polarized, NC	<b>Ordering code</b>
	Part number
Supply voltage $U_S$	
Voltage drop $U_d$ at $I_o$ max.	
Rated insulation voltage $U_i$	
Rated operating current $I_o$	
Minimum operating current $I_m$	
Residual current $I_r$ max.	
Permissible load capacitance max.	
Polarity reversal protected/transposition protected/short-circuit protected	
Ambient temperature $T_a$	
Switching frequency $f$ max.	
Output function indicator	
Degree of protection as per IEC 60529	
Approvals	
Material	Housing
	Sensing surface
Connection	

Wiring diagrams, see page 958.

The meaning of switching distance markings can be found on page 962.

**Additional cable lengths on request.**

## Recommendation for connection wiring for polarized sensors on 3-wire controllers

PNP, NO

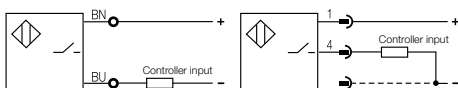

NPN, NO

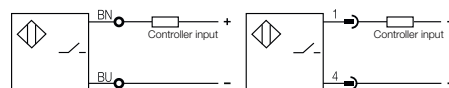

PNP, normally closed

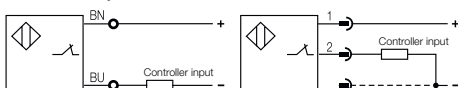

NPN, NC

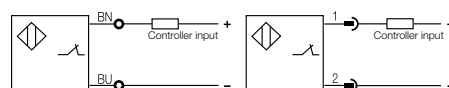



**Global**



**Global**

M8x1	M8x1	M8x1	M8x1
Flush	Flush	Flush	Flush
<b>2 mm</b>	<b>2 mm</b>	<b>1.5 mm</b>	<b>2 mm</b>
0...1.6 mm	0...1.6 mm	0...1.2 mm	0...1.6 mm
■ ■	■ ■	■	■ ■
<b>BES0022</b>			<b>BES001Z</b>
BES M08ME1-GSC20B-S04G			BES M08MG-GSC20B-BP00,3-GS04
<b>BES024N</b>			<b>BES03H8</b>
BES M08ME1-GOC20B-S04G			BES M08MG-GOC20B-BP00,3-GS04
<b>BES001Y</b>	<b>BES03KP</b>		
BES M08ME1-USC20B-S04G	BES M08ME1-USH20B-S04G		
<b>BES024P</b>		<b>BES031N</b>	
BES M08ME1-UOC20B-S04G		BES 516-527-S4-H	
10...36 V DC	10...55 V DC	10...55 V DC	10...36 V DC
5 V	5 V	5 V	5 V
75 V DC	75 V DC	75 V DC	75 V DC
100 mA	100 mA	130 mA	100 mA
5 mA	5 mA	5 mA	5 mA
600 µA	600 µA	500 µA	600 µA
1 µF	1 µF	1 µF	1 µF
Yes/Yes/Yes	Yes/Yes/Yes	Yes/Yes/Yes	Yes/Yes/Yes
-25...+70 °C	-25...+70 °C	-25...+70 °C	-25...+70 °C
1.5 kHz	1.5 kHz	3 kHz	1.5 kHz
Yellow LED	Yellow LED	Yellow LED	Yellow LED
IP 67	IP 67	IP 67	IP 67
CE, cULus	CE	CE, cULus	CE, cULus
Brass-coated	Brass-coated	Stainless steel	Brass-coated
PBT	PBT	PBT	PBT
M12 connector, 4-pin	M12 connector, 4-pin	M12 connector, 4-pin	0.3 m PUR cable with M12 connector, 4-pin

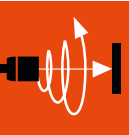

- Inductive Sensors
- Global DC 3-wire
- DC 3-/4-wire
- DC 2-wire
- Cylinder Designs
- Block Designs
- AC/DC 2-wire
- AC 2-wire
- Special Properties
- Analog Distance Measurement
- Accessories

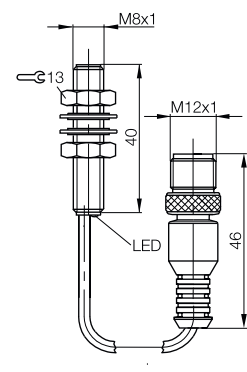
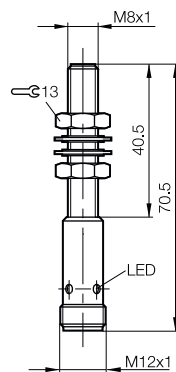
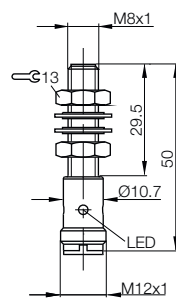
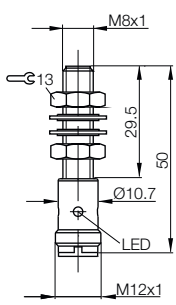

# DC 2-wire Inductive Sensors

## Cylinder designs, M8x1



Model	<b>M8x1</b>	<b>M8x1</b>	
Installation type (observe instructions in the Basic Information chapter)	Flush	Flush	
Rated switching distance $s_n$	<b>2 mm</b>	<b>2 mm</b>	
Assured switching distance $s_a$	0...1.6 mm	0...1.4 mm	
Switching distance marking	■■	■■	
Polarized, NO	<b>Ordering code</b>	<b>BES03KR</b>	<b>BES0324</b>
	Part number	BES M08MG-GSH20B-BP00,3-GS04	BES M08MG-GSC20B-BP00,3-GS04-101
Polarized, NC	<b>Ordering code</b>		
	Part number		
Non-polarized, NO	<b>Ordering code</b>		
	Part number		
Non-polarized, NC	<b>Ordering code</b>		
	Part number		
Supply voltage $U_S$	10...55 V DC	10...30 V DC	
Voltage drop $U_d$ at $I_o$ max.	5 V	5 V	
Rated insulation voltage $U_i$	75 V DC	75 V DC	
Rated operating current $I_o$	100 mA	100 mA	
Minimum operating current $I_m$	5 mA	5 mA	
Residual current $I_r$ max.	600 $\mu$ A	600 $\mu$ A	
Permissible load capacitance max.	1 $\mu$ F	1 $\mu$ F	
Polarity reversal protected/transposition protected/short-circuit protected	Yes/Yes/Yes	Yes/Yes/Yes	
Ambient temperature $T_a$	-25...+70 °C	-25...+70 °C	
Switching frequency $f$ max.	1.5 kHz	1.5 kHz	
Output function indicator	Yellow LED	Yellow LED	
Degree of protection as per IEC 60529	IP 67	IP 67	
Approvals	CE	CE, cULus	
Material	Housing Sensing surface	Brass-coated PBT	<b>With ceramic coating</b>
Connection	0.3 m PUR cable with M12 connector, 4-pin	0.3 m PUR cable with M12 connector, 4-pin	

Wiring diagrams, see page 958.  
The meaning of switching distance markings can be found on page 962.

**Additional cable lengths and PUR cable jacket material available on request.**

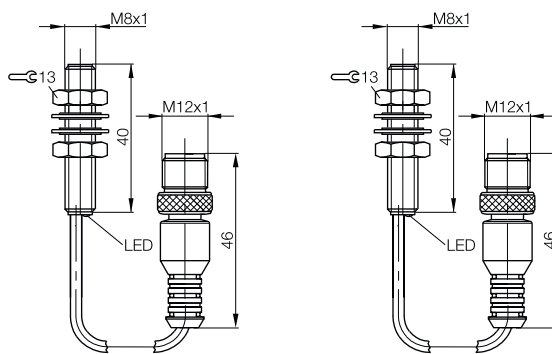



Global

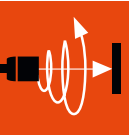

<b>M8x1</b>	<b>M8x1</b>		
Flush	Flush		
<b>2 mm</b>	<b>2 mm</b>		
0...1.6 mm	0...1.6 mm		
■ ■	■ ■		
<b>BES001L</b>			
BES M08MG-GSC20B-BV02			
<b>BES024R</b>			
BES M08MG-GOC20B-BV02			
<b>BES001T</b>	<b>BES03KT</b>		
BES M08MG-USC20B-BV02	BES M08MG-USH20B-BV02		
<b>BES024T</b>			
BES M08MG-UOC20B-BV02			
10...36 V DC	10...55 V DC		
5 V	5 V		
75 V DC	75 V DC		
100 mA	100 mA		
5 mA	5 mA		
600 µA	600 µA		
1 µF	1 µF		
Yes/Yes/Yes	Yes/Yes/Yes		
-25...+70 °C	-25...+70 °C		
1.5 kHz	1.5 kHz		
Yellow LED	Yellow LED		
IP 67	IP 67		
CE, cULus	CE		
Brass-coated	Brass-coated		
PBT	PBT		
2 m PVC cable, 2x0.14 mm <sup>2</sup>	2 m PVC cable, 2x0.14 mm <sup>2</sup>		

Inductive Sensors

Global DC 3-wire

DC 3-/4-wire

DC 2-wire

Cylinder Designs

Block Designs

AC/DC 2-wire

AC 2-wire

Special Properties

Analog Distance Measurement

Accessories

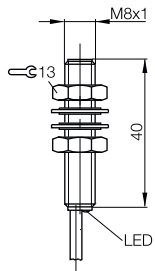
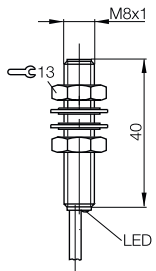

# DC 2-wire Inductive Sensors

## Cylinder designs, M12x1



Global



Model		<b>M12x1</b>	<b>M12x1</b>	<b>M12x1</b>	
Installation type (observe instructions in the Basic Information chapter)		Flush	Flush	Flush	
Rated switching distance $s_n$		<b>3 mm</b>	<b>3 mm</b>	<b>3 mm</b>	
Assured switching distance $s_a$		0...2.4 mm	0...2.2 mm	0...2.4 mm	
Switching distance marking		■ ■	■ ■	■ ■	
Polarized, NO	<b>Ordering code</b>	<b>BES003Z</b>	<b>BES00C1</b>		
	Part number	BES M12MF-GSC30B-S04G	BES M12MF-GSC30B-S04G-101		
Polarized, NC	<b>Ordering code</b>	<b>BES024J</b>			
	Part number	BES M12MF-GOC30B-S04G			
Non-polarized, NO	<b>Ordering code</b>	<b>BES0041</b>		<b>BES03KU</b>	
	Part number	BES M12MF-USC30B-S04G		BES M12MF-USH30B-S04G	
Non-polarized, NC	<b>Ordering code</b>	<b>BES024K</b>			
	Part number	BES M12MF-UOC30B-S04G			
Supply voltage $U_S$		10...36 V DC	10...30 V DC	10...55 V DC	
Voltage drop $U_d$ at $I_o$ max.		≤ 5 V	5 V	5 V	
Rated insulation voltage $U_i$ (protection class)		75 V DC	75 V DC	75 V DC	
Rated operating current $I_o$		100 mA	100 mA	100 mA	
Minimum operating current $I_m$		5 mA	5 mA	5 mA	
Residual current $I_r$ max.		600 $\mu$ A	600 $\mu$ A	600 $\mu$ A	
Permissible load capacitance max.		1 $\mu$ F	1 $\mu$ F	1 $\mu$ F	
Polarity reversal protected/transposition protected/short-circuit protected		Yes/Yes/Yes	Yes/Yes/Yes	Yes/Yes/Yes	
Ambient temperature $T_a$		-25...+70 °C	-25...+70 °C	-25...+70 °C	
Switching frequency $f$ max.		1.3 kHz	1.5 kHz	1.3 kHz	
Output function indicator		Yellow LED	Yellow LED	Yellow LED	
Degree of protection as per IEC 60529		IP 67	IP 67	IP 67	
Approvals		CE, cULus	CE, cULus	CE	
Material	Housing	Brass-coated	Brass-coated	Brass-coated	
	Sensing surface	PA 12	<b>With ceramic coating</b>	PA 12	
Connection		M12 connector, 4-pin	M12 connector, 4-pin	M12 connector, 4-pin	

Wiring diagrams, see page 958.

The meaning of switching distance markings can be found on page 962.

**Additional cable lengths and PUR cable jacket material available on request.**

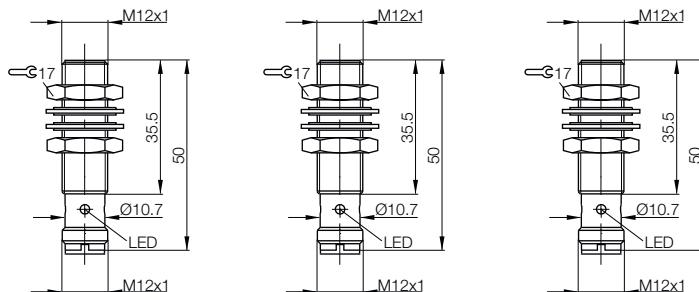



# DC 2-wire Inductive Sensors Cylinder designs, M12x1



M12x1	M12x1	M12x1	M12x1	M12x1
Flush	Flush	Flush	Flush	Flush
<b>3 mm</b>	<b>3 mm</b>	<b>3 mm</b>	<b>3 mm</b>	<b>3 mm</b>
0...2.4 mm	0...2.2 mm	0...2.4 mm	0...2.4 mm	0...2.4 mm
■ ■	■ ■	■ ■	■ ■	■ ■
<b>BES0042</b>	<b>BES0326</b>	<b>BES03KW</b>	<b>BES0045</b>	
BES M12MG-GSC30B-BP00,3-GS04	BES M12MG-GSC30B-BP00,3-GS04-101	BES M12MG-GSH30B-BP00,3-GS04	BES M12MG-GSC30B-BV02	
<b>BES03HK</b>			<b>BES024L</b>	
BES M12MG-GOC30B-BP00,3-GS04			BES M12MG-GOC30B-BV02	
			<b>BES004T</b>	<b>BES03KN</b>
			BES M12MG-USC30B-BV02	BES M12MG-USH30B-BV02
			<b>BES024M</b>	
			BES M12MG-UOC30B-BV02	
10...36 V DC	10...30 V DC	10...55 V DC	10...36 V DC	10...55 V DC
4 V	4 V	4 V	≤ 5 V	5 V
75 V DC	75 V DC	75 V DC	75 V DC	75 V DC
100 mA	100 mA	100 mA	100 mA	100 mA
5 mA	5 mA	5 mA	5 mA	5 mA
600 µA	600 µA	600 µA	600 µA	600 µA
1 µF	1 µF	1 µF	1 µF	1 µF
Yes/Yes/Yes	Yes/Yes/Yes	Yes/Yes/Yes	Yes/Yes/Yes	Yes/Yes/Yes
-25...+70 °C	-25...+70 °C	-25...+70 °C	-25...+70 °C	-25...+70 °C
1.3 kHz	1.3 kHz	1.3 kHz	1.3 kHz	1.3 kHz
Yellow LED	Yellow LED	Yellow LED	Yellow LED	Yellow LED
IP 67	IP 67	IP 67	IP 67	IP 67
CE, cULus	CE, cULus	CE	CE, cULus	CE
Brass-coated	Brass-coated	Brass-coated	Brass-coated	Brass-coated
PA 12	<b>With ceramic coating</b>	PA 12	PA 12	PA 12
0.3 m PUR cable with M12 connector, 4-pin	0.3 m PUR cable with M12 connector, 4-pin	0.3 m PUR cable with M12 connector, 4-pin	2 m PVC cable, 2x0.34 mm <sup>2</sup>	2 m PVC cable, 2x0.34 mm <sup>2</sup>

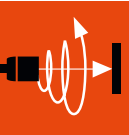

Inductive Sensors

Global DC 3-wire

DC 3-/4-wire

DC 2-wire

Cylinder Designs

Block Designs

AC/DC 2-wire

AC 2-wire

Special Properties

Analog Distance Measurement

Accessories

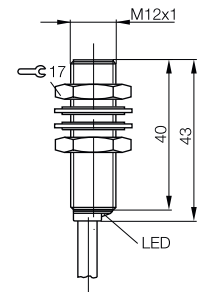
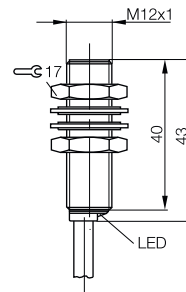
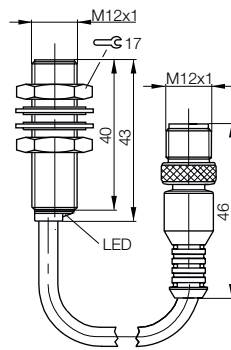
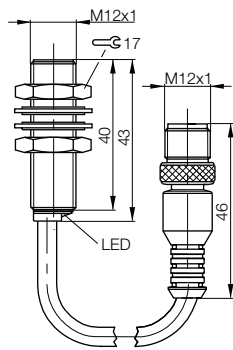
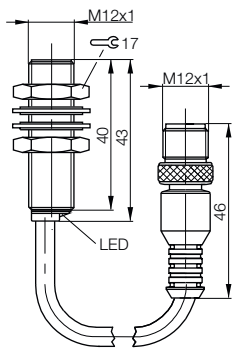

# DC 2-wire Inductive Sensors

## Cylinder designs, M18x1



Model	<b>M18x1</b>	<b>M18x1</b>	<b>M18x1</b>	
Installation type (observe instructions in the Basic Information chapter)	Flush	Flush	Flush	
Rated switching distance $s_n$	<b>5 mm</b>	<b>7 mm</b>	<b>7 mm</b>	
Assured switching distance $s_a$	0...4 mm	0...5.6 mm	0...5.6 mm	
Switching distance marking	■	■■	■■■	
Polarized, NO	<b>Ordering code</b>	<b>BES0328</b>		
	Part number	BES M18MF-GSC70B-S04G		
Polarized, NC	<b>Ordering code</b>	<b>BES02NL</b>		
	Part number	BES M18MF-GOC70B-S04G		
Non-polarized, NO	<b>Ordering code</b>	<b>BES02NR</b>	<b>BES039M</b>	
	Part number	BES M18MF-USC70B-S04G	BES M18MF-USH70B-S04K	
Non-polarized, NC	<b>Ordering code</b>	<b>BES02NN</b>		
	Part number	BES M18MF-UOC70B-S04G		
Supply voltage $U_s$	10...55 V DC	10...36 V DC	10...55 V DC	
Voltage drop $U_d$ at $I_o$ max.	5 V	≤ 5 V	5 V	
Rated insulation voltage $U_i$	250 V AC (□)	75 V DC	75 V DC	
Rated operating current $I_o$	200 mA	100 mA	100 mA	
Minimum operating current $I_m$	5 mA	5 mA	5 mA	
Residual current $I_r$ max.	500 $\mu$ A	600 $\mu$ A	600 $\mu$ A	
Permissible load capacitance max.	1 $\mu$ F	1 $\mu$ F	1 $\mu$ F	
Polarity reversal protected/transposition protected/short-circuit protected	Yes/Yes/Yes	Yes/Yes/Yes	Yes/Yes/Yes	
Ambient temperature $T_a$	-25...+70 °C	-25...+70 °C	-25...+70 °C	
Switching frequency $f$ max.	250 Hz	600 Hz	600 Hz	
Output function indicator	Yellow LED	Yellow LED	Yellow LED	
Degree of protection as per IEC 60529	IP 68 per BWN Pr. 20	IP 67	IP 67	
Approvals	CE, cULus	CE, cULus	CE	
Material	Housing Sensing surface	Brass-coated PA 12	Brass-coated PA 12	Brass-coated PA 12
Connection	M12 connector, 4-pin	M12 connector, 4-pin	M12 connector, 4-pin	

Wiring diagrams, see page 958.  
The meaning of switching distance markings can be found on page 962.

**Additional cable lengths and PUR cable jacket material available on request.**

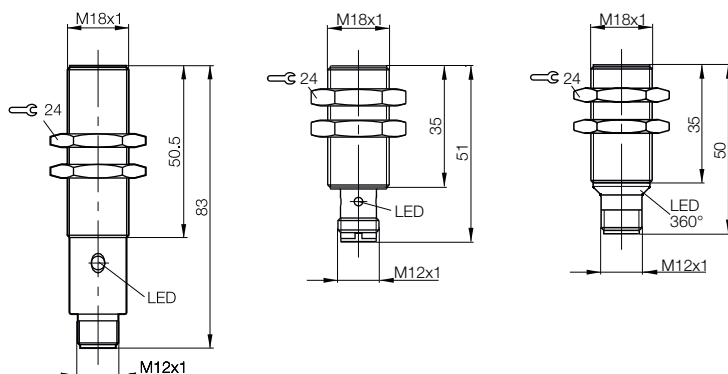



Global



Global

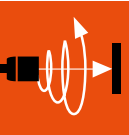

Inductive Sensors

Global DC 3-wire

DC 3-/4-wire

DC 2-wire  
Cylinder Designs

Block Designs

AC/DC 2-wire

AC 2-wire

Special Properties

Analog Distance Measurement

Accessories

M18x1	M18x1	M18x1	M18x1
Flush	Flush	Flush	Flush
<b>7 mm</b>	<b>7 mm</b>	<b>7 mm</b>	<b>7 mm</b>
0...5.6 mm	0...5.5 mm	0...5.6 mm	0...5.6 mm
■ ■	■ ■	■ ■	■ ■
<b>BES006C</b>	<b>BES0329</b>	<b>BES039P</b>	<b>BES00FA</b>
BES M18MG-GSC70B-BP00,3-GS04	BES M18MG-GSC70B-BP00,3-GS04-101	BES M18MG-GSH70B-BP00,3-GS04	BES M18MG-GSC70B-BV02
<b>BES039L</b>			<b>BES02NT</b>
BES M18MG-GOC70B-BP00,3-GS04			BES M18MG-GOC70B-BV02
			<b>BES0073</b>
			BES M18MG-USC70B-BV02
			<b>BES02NU</b>
			BES M18MG-UOC70B-BV02
10...36 V DC	10...30 V DC	10...55 V DC	10...36 V DC
4 V	4 V	4 V	≤ 5 V
75 V DC	75 V DC	75 V DC	75 V DC
100 mA	100 mA	100 mA	100 mA
5 mA	5 mA	5 mA	5 mA
600 µA	600 µA	600 µA	600 µA
1 µF	1 µF	1 µF	1 µF
Yes/Yes/Yes	Yes/Yes/Yes	Yes/Yes/Yes	Yes/Yes/Yes
-25...+70 °C	-25...+70 °C	-25...+70 °C	-25...+70 °C
600 Hz	600 Hz	600 Hz	600 Hz
Yellow LED	Yellow LED	Yellow LED	Yellow LED
IP 67	IP 67	IP 67	IP 67
CE, cULus	CE, cULus	CE	CE, cULus
Brass-coated	Brass-coated	Brass-coated	Brass-coated
PA 12	<b>With ceramic coating</b>	PA 12	PA 12
0.3 m PUR cable with M12 connector, 4-pin	0.3 m PUR cable with M12 connector, 4-pin	0.3 m PUR cable with M12 connector, 4-pin	2 m PVC cable, 3x0.34 mm <sup>2</sup>

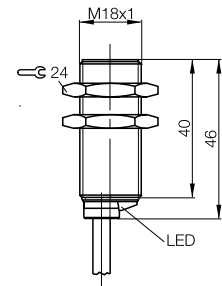
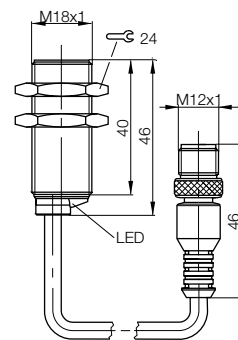
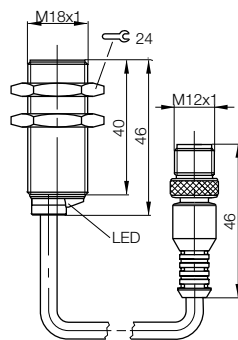
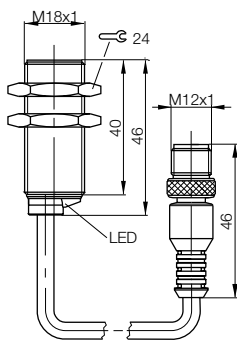

# DC 2-wire Inductive Sensors

## Cylinder designs, M18x1



Model	<b>M18x1</b>	<b>M18x1</b>	
Installation type (observe instructions in the Basic Information chapter)	Flush	Not flush	
Rated switching distance $s_n$	<b>7 mm</b>	<b>8 mm</b>	
Assured switching distance $s_a$	0...5.6 mm	0...6.5 mm	
Switching distance marking	■ ■	■	
Polarized, NO	<b>Ordering code</b>		
	Part number		
Polarized, NC	<b>Ordering code</b>		
	Part number		
Non-polarized, NO	<b>Ordering code</b>	<b>BES039N</b>	
	Part number	BES M18MG-USH70B-BV02	
Non-polarized, NC	<b>Ordering code</b>		<b>BES0322</b>
	Part number		BES 516-547-S4-H
Supply voltage $U_s$	10...55 V DC	10...55 V DC	
Voltage drop $U_d$ at $I_o$ max.	5 V	5 V	
Rated insulation voltage $U_i$ (protection class)	75 V DC	250 V AC (□)	
Rated operating current $I_o$	100 mA	200 mA	
Minimum operating current $I_m$	5 mA	5 mA	
Residual current $I_r$ max.	600 $\mu$ A	500 $\mu$ A	
Permissible load capacitance max.	1 $\mu$ F	1 $\mu$ F	
Polarity reversal protected/transposition protected/short-circuit protected	Yes/Yes/Yes	Yes/Yes/Yes	
Ambient temperature $T_a$	-25...+70 °C	-25...+70 °C	
Switching frequency $f$ max.	600 Hz	200 Hz	
Output function indicator	Yellow LED	Yellow LED	
Degree of protection as per IEC 60529	IP 67	IP 68 per BWN Pr. 20	
Approvals	CE	CE, cULus	
Material	Housing Sensing surface	Brass-coated PA 12	Brass-coated PA 12
Connection	2 m PVC cable, 2x0.34 mm <sup>2</sup>	M12 connector, 4-pin	

Wiring diagrams, see page 958.

The meaning of switching distance markings can be found on page 962.

**Additional cable lengths and PUR cable jacket material available on request.**

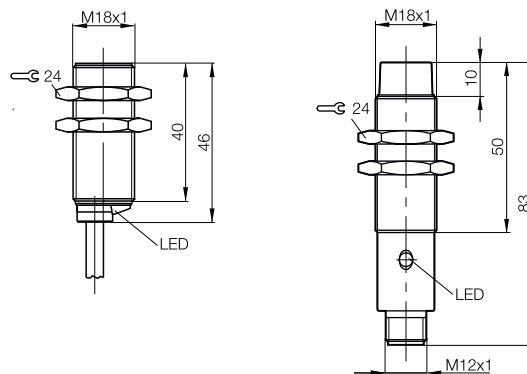



**Global**



**Global**



M30x1.5	M30x1.5	M30x1.5	M30x1.5
Flush	Flush	Flush	Flush
<b>10 mm</b>	<b>15 mm</b>	<b>15 mm</b>	<b>15 mm</b>
0...8 mm	0...12 mm	0...12 mm	0...12 mm
■	■ ■	■ ■	■ ■
	<b>BES027L</b>	<b>BES008W</b>	
	BES M30MF-GSC15B-S04G	BES M30MF-GSC15B-S04K	
	<b>BES027C</b>	<b>BES027J</b>	
	BES M30MF-GOC15B-S04G	BES M30MF-GOC15B-S04K	
	<b>BES027E</b>	<b>BES0094</b>	<b>BES03FP</b>
	BES M30MF-USC15B-S04G	BES M30MF-USC15B-S04K	BES M30MF-USH15B-S04K
<b>BES031T</b>	<b>BES027F</b>	<b>BES027H</b>	
BES 516-541-S4-H	BES M30MF-UOC15B-S04G	BES M30MF-UOC15B-S04K	
10...55 V DC	10...36 V DC	10...36 V DC	10...55 V DC
5 V	≤ 5 V	≤ 5 V	5 V
250 V AC (□)	75 V DC	75 V DC	75 V DC
200 mA	100 mA	100 mA	100 mA
5 mA	5 mA	5 mA	5 mA
500 μA	600 μA	600 μA	600 μA
1 μF	1 μF	1 μF	1 μF
Yes/Yes/Yes	Yes/Yes/Yes	Yes/Yes/Yes	Yes/Yes/Yes
-25...+70 °C	-25...+70 °C	-25...+70 °C	-25...+70 °C
150 Hz	400 Hz	400 Hz	400 Hz
Yellow LED	Yellow LED	Yellow LED	Yellow LED
IP 68 per BWN Pr. 20	IP 67	IP 67	IP 67
CE, cULus	CE, cULus	CE, cULus	CE
Brass-coated	Brass-coated	Brass-coated	Brass-coated
PA 12	PA 12	PA 12	PA 12
M12 connector, 4-pin	M12 connector, 4-pin	M12 connector, 4-pin	M12 connector, 4-pin

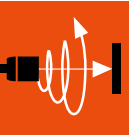

Inductive Sensors

Global DC 3-wire

DC 3-/4-wire

DC 2-wire

Cylinder Designs

Block Designs

AC/DC 2-wire

AC 2-wire

Special Properties

Analog Distance Measurement

Accessories

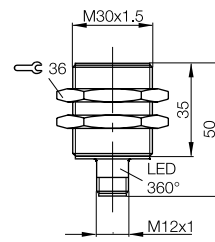
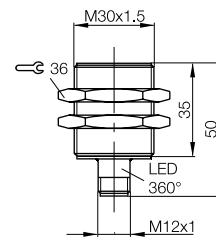
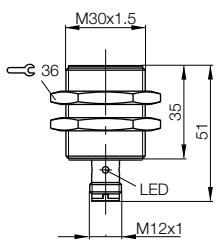
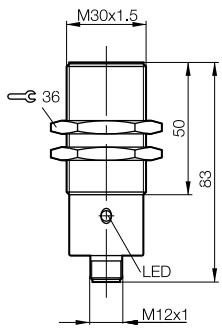

# DC 2-wire Inductive Sensors

## Cylinder designs, M30×1.5



Model		<b>M30×1.5</b>	<b>M30×1.5</b>
Installation type (observe instructions in the Basic Information chapter)		Flush	Flush
Rated switching distance $s_n$		<b>15 mm</b>	<b>15 mm</b>
Assured switching distance $s_a$		0...12 mm	0...12 mm
Switching distance marking		■■	■■
Polarized, NO	<b>Ordering code</b>	<b>BES03H5</b>	<b>BES032A</b>
	Part number	BES M30MF-GSH15B-BP00,3-GS04	BES M30MF-GSC15B-BP00,3-GS04-101
Polarized, NC	<b>Ordering code</b>		
	Part number		
Non-polarized, NO	<b>Ordering code</b>		
	Part number		
Non-polarized, NC	<b>Ordering code</b>		
	Part number		
Supply voltage $U_S$		10...55 V DC	10...36 V DC
Voltage drop $U_d$ at $I_e$ max.		4 V	4 V
Rated insulation voltage $U_i$ (protection class)		75 V DC	75 V DC
Rated operating current $I_e$		100 mA	100 mA
Minimum operating current $I_m$		5 mA	5 mA
Residual current $I_r$ max.		600 $\mu$ A	600 $\mu$ A
Permissible load capacitance max.		1 $\mu$ F	1 $\mu$ F
Polarity reversal protected/transposition protected/short-circuit protected		Yes/Yes/Yes	Yes/Yes/Yes
Ambient temperature $T_a$		-25...+70 °C	-25...+70 °C
Switching frequency $f$ max.		400 Hz	400 Hz
Output function indicator		Yellow LED	Yellow LED
Degree of protection as per IEC 60529		IP 67	IP 67
Approvals		CE	CE, cULus
Material	Housing	Brass-coated	Brass-coated
	Sensing surface	PA 12	<b>With ceramic coating</b>
Connection		0.3 m PUR cable with M12 connector, 4-pin	0.3 m PUR cable with M12 connector, 4-pin

Wiring diagrams, see page 958.  
The meaning of switching distance markings can be found on page 962.

**Additional cable lengths and PUR cable jacket material available on request.**

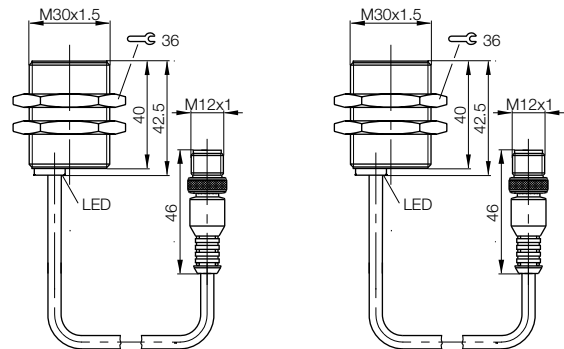



Global



Global



M30x1.5	M30x1.5	M30x1.5	M30x1.5
Flush	Flush	Flush	Not flush
<b>15 mm</b>	<b>15 mm</b>	<b>15 mm</b>	<b>15 mm</b>
0...12 mm	0...12 mm	0...12 mm	0...12 mm
■ ■	■ ■	■ ■	■
<b>BES008Y</b>	<b>BES008R</b>		
BES M30MF-GSC15B-BP00,3-GS04	BES M30MF-GSC15B-BV02		
<b>BES03H4</b>	<b>BES0279</b>		
BES M30MF-GOC15B-BP00,3-GS04	BES M30MF-GOC15B-BV02		
	<b>BES0091</b>	<b>BES03FT</b>	
	BES M30MF-USC15B-BV02	BES M30MF-USH15B-BV02	
	<b>BES027A</b>		<b>BES0323</b>
	BES M30MF-UOC15B-BV02		BES 516-549-S4-H
10...36 V DC	10...36 V DC	10...55 V DC	10...55 V DC
4 V	≤ 5 V	5 V	5 V
75 V DC	75 V DC	75 V DC	250 V AC (□)
100 mA	100 mA	100 mA	200 mA
5 mA	5 mA	5 mA	5 mA
600 µA	600 µA	600 µA	500 µA
1 µF	1 µF	1 µF	1 µF
Yes/Yes/Yes	Yes/Yes/Yes	Yes/Yes/Yes	Yes/Yes/Yes
-25...+70 °C	-25...+70 °C	-25...+70 °C	-25...+70 °C
400 Hz	400 Hz	400 Hz	100 Hz
Yellow LED	Yellow LED	Yellow LED	Yellow LED
IP 67	IP 67	IP 67	IP 68 per BWN Pr. 20
CE, cULus	CE, cULus	CE	CE, cULus
Brass-coated	Brass-coated	Brass-coated	Brass-coated
PA 12	PA 12	PA 12	PA 12
0.3 m PUR cable with M12 connector, 4-pin	2 m PVC cable, 2x0.34 mm <sup>2</sup>	2 m PVC cable, 2x0.34 mm <sup>2</sup>	M12 connector, 4-pin

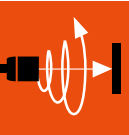

Inductive Sensors

Global DC 3-wire

DC 3-/4-wire

DC 2-wire

Cylinder Designs

Block Designs

AC/DC 2-wire

AC 2-wire

Special Properties

Analog Distance Measurement

Accessories

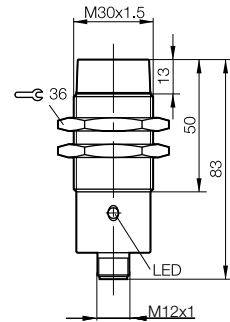
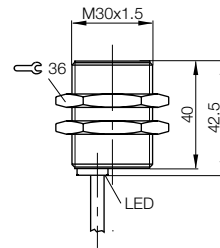
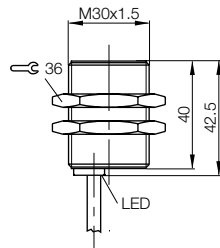
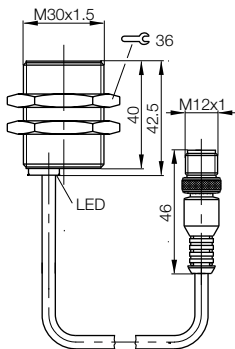

# DC 2-wire Inductive Sensors

## Block designs, 20×32×8 mm



Model	<b>20×32×8 mm R01</b>	
Installation type (observe instructions in the Basic Information chapter)	Flush	
Rated switching distance $s_n$	<b>5 mm</b>	
Assured switching distance $s_a$	0...3.9 mm	
Switching distance marking	■	
Non-polarized, NO	<b>Ordering code</b>	<b>BES03TM</b>
	Part number	BES R01ZC-USC50B-BP00.2-GS04-101
Supply voltage $U_s$	10...30 V DC	
Voltage drop $U_d$ at $I_e$ max.	5 V	
Rated insulation voltage $U_i$	75 V DC	
Rated operating current $I_e$	100 mA	
Minimum operating current $I_m$	5 mA	
Residual current $I_r$ max.	600 $\mu$ A	
Permissible load capacitance max.	1 $\mu$ F	
Polarity reversal protected/transposition protected/short-circuit protected	Yes/Yes/Yes	
Ambient temperature $T_a$	-25...+70 °C	
Switching frequency $f$ max.	300 Hz	
Output function indicator	Yellow LED	
Degree of protection as per IEC 60529	IP 67	
Approvals	CE	
Material	Housing	Cast zinc
	Sensing surface	<b>With ceramic coating</b>
Connection	0.2 m PUR cable with M12 connector, 4-pin	

Wiring diagrams, see page 958.  
The meaning of switching distance markings can be found on page 962.

**Additional cable lengths and PUR cable jacket material available on request.**

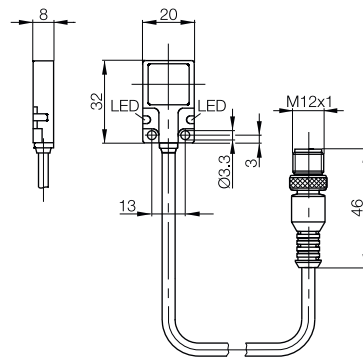



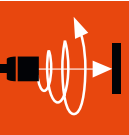

Inductive Sensors  
Global DC 3-wire  
DC 3-/4-wire  
DC 2-wire  
Cylinder Designs  
**Block Designs**  
AC/DC 2-wire  
AC 2-wire  
Special Properties  
Analog Distance Measurement  
Accessories

Model	26×26×26 mm Z03	26×26×26 mm Z03
Installation type (observe instructions in the Basic Information chapter)	Flush	Flush
Rated switching distance $s_n$	<b>10 mm</b>	<b>10 mm</b>
Assured switching distance $s_a$	0...8.1 mm	0...8.1 mm
Switching distance marking	■	■
Polarized, NO	<b>BES030H</b>	<b>BES030E</b>
Ordering code	BES Z03K-GSS10B-S04U-006	BES Z03K-GSS10B-EP00,15-GS04-006
Part number		
Supply voltage $U_s$	10...36 V DC	10...36 V DC
Voltage drop $U_d$ at $I_e$ max.	4.6 V	4.6 V
Rated insulation voltage $U_i$ (protection class)	250 V AC (□)	250 V AC (□)
Rated operating current $I_e$	100 mA	100 mA
Minimum operating current $I_m$	2 mA	2 mA
Residual current $I_r$ max.	600 $\mu$ A	600 $\mu$ A
Permissible load capacitance max.	0.1 $\mu$ F	0.1 $\mu$ F
Polarity reversal protected/transposition protected/short-circuit protected	Yes/Yes/Yes	Yes/Yes/Yes
Ambient temperature $T_a$	-25...+70 °C	-25...+70 °C
Switching frequency $f$ max.	250 Hz	250 Hz
Output function indicator	Yellow LED	Yellow LED
Degree of protection as per IEC 60529	IP 67	IP 67
Approvals	CE	CE
Material	PA	PA
Housing	PA	PA
Sensing surface	PA	PA
Connection	M12 connector, 4-pin	0.15 m PUR cable with M12 connector, 4-pin

Wiring diagrams, see page 958.  
The meaning of switching distance markings can be found on page 962.

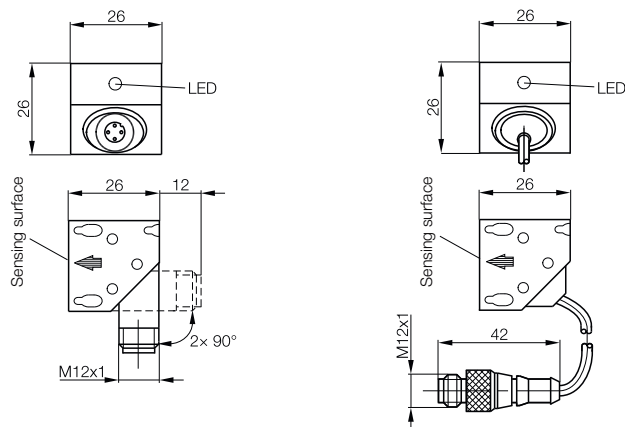

**Small, compact block sensor with increased switching distance for quick installation**

The connector mount can be rotated and the sensing face can be oriented in three directions.

Simple replacement with no loss of position thanks to the fixed mounting plate:

- Cost savings
- No special tools necessary
- Simple to install

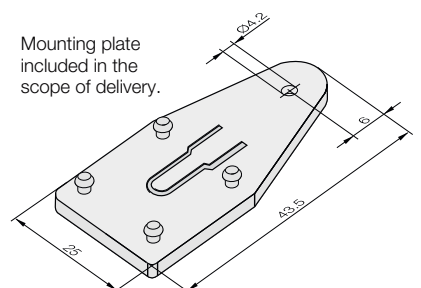
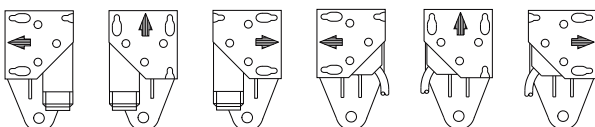

Mounting plate included in the scope of delivery.

# DC 2-wire Inductive Sensors

## Block designs, 40×66×40 mm



Model		40×66×40 mm Unicompact	40×66×40 mm Unicompact
Installation type (observe instructions in the Basic Information chapter)		Flush	Flush
Rated switching distance $s_n$		<b>15 mm</b>	<b>15 mm</b>
Assured switching distance $s_a$		0...12 mm	0...12 mm
Switching distance marking		■	■
Polarized, NO	<b>Ordering code</b>	<b>BES0303</b>	<b>BES0302</b>
	Part number	BES Q40KFU-GSH15B-S04G	BES Q40KFU-GSH15B-EP00,8-GS04
Polarized, NC	<b>Ordering code</b>		<b>BES0301</b>
	Part number		BES Q40KFU-GOH15B-EP00,8-GS04
Supply voltage $U_S$		10...55 V DC	10...55 V DC
Voltage drop $U_d$ at $I_e$ max.		4.6 V	4.6 V
Rated insulation voltage $U_i$ (protection class)		250 V AC (□)	250 V AC (□)
Rated operating current $I_e$		100 mA	100 mA
Minimum operating current $I_m$		2 mA	5 mA
Residual current $I_r$ max.		800 $\mu$ A	800 $\mu$ A
Permissible load capacitance max.		1 $\mu$ F	1 $\mu$ F
Polarity reversal protected/transposition protected/short-circuit protected		Yes/Yes/Yes	Yes/Yes/Yes
Ambient temperature $T_a$		-25...+70 °C	-25...+70 °C
Switching frequency $f$ max.		150 Hz	150 Hz
Output function indicator		Yellow LED	Yellow LED
Degree of protection as per IEC 60529		IP 67	IP 67
Approvals		CE	CE
Material	Housing	PPE, PPS	PPE, PPS
	Sensing surface	PPE	PPE
Connection		M12 connector, 4-pin	0.8 m PUR cable with M12 connector, 4-pin

Wiring diagrams, see page 958.  
The meaning of switching distance markings can be found on page 962.

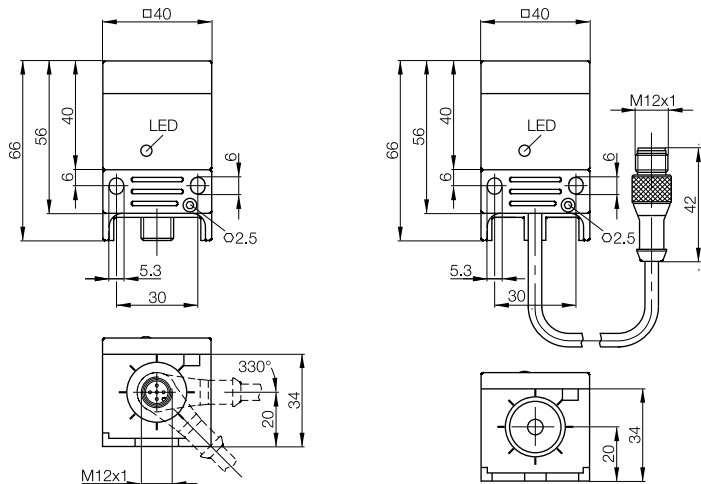

### Unicompact

The flexible sensor for mechanical engineering and equipment manufacturing. The detection direction can be adjusted in 5 directions. Long switching distance in compact package.

### Permissible installation variations for Unicompact

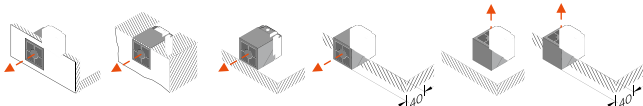

# DC 2-wire Inductive Sensors

## Block designs, 40×121×40 mm

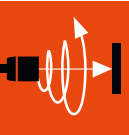

Model	<b>40×121×40 mm Unisensor</b>	
Installation type (observe instructions in the Basic Information chapter)	Not flush	
Rated switching distance $s_n$	<b>20 mm</b>	
Assured switching distance $s_a$	0...16 mm	
Switching distance marking	■	
Polarized, complementary	<b>Ordering code</b>	<b>BES0309</b>
	Part number	BES Q40KU-GPH20F-KM21
Supply voltage $U_S$	10...55 V DC	
Voltage drop $U_d$ at $I_o$ max.	4.6 V	
Rated insulation voltage $U_i$ (protection class)	250 V AC (II)	
Rated operating current $I_o$	400 mA	
Minimum operating current $I_m$	4 mA	
Residual current $I_r$ max.	1 mA	
Permissible load capacitance max.	1 $\mu$ F	
Polarity reversal protected/transposition protected/short-circuit protected	Yes/Yes/Yes	
Ambient temperature $T_a$	-25...+80 °C	
Switching frequency $f$ max.	300 Hz	
Output function indicator	Red LED	
Degree of protection as per IEC 60529	IP 65	
Approvals	CE	
Material	Housing	PPE
	Sensing surface	PPE
Connection	Screw terminal	

Inductive Sensors  
Global DC 3-wire  
DC 3-/4-wire  
DC 2-wire  
Cylinder Designs  
**Block Designs**  
AC/DC 2-wire  
AC 2-wire  
Special Properties  
Analog Distance Measurement

Accessories

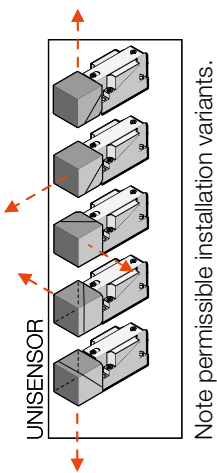

Wiring diagrams, see page 958.  
The meaning of switching distance markings can be found on page 962.

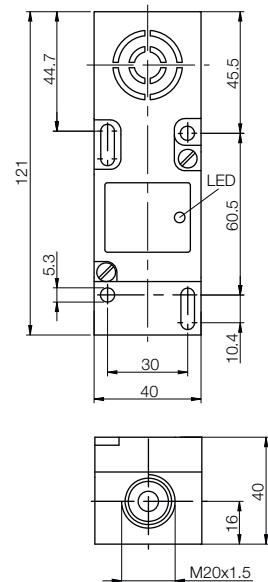

### Installation variations

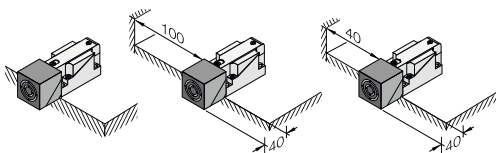

### Row mounting

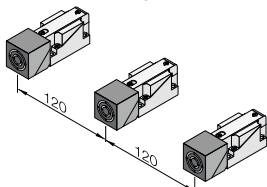

# DC 2-wire Inductive Sensors

## Block designs, 80×92×40 mm



Model	<b>80×92×40 mm</b> Maxisensor	
Installation type (observe instructions in the Basic Information chapter)	Flush	
Rated switching distance $s_n$	<b>50 mm</b>	
Assured switching distance $s_a$	0...40 mm	
Switching distance marking	■	
Polarized, NO	<b>Ordering code</b>	<b>BES030A</b>
	Part number	BES Q80KA-GSH50B-S04Q
Supply voltage $U_S$	10...55 V DC	
Voltage drop $U_d$ at $I_e$ max.	4.6 V	
Rated insulation voltage $U_i$ (protection class)	250 V AC (Ⓜ)	
Rated operating current $I_e$	400 mA	
Minimum operating current $I_m$	4 mA	
Residual current $I_r$ max.	600 $\mu$ A	
Permissible load capacitance max.	1 $\mu$ F	
Polarity reversal protected/transposition protected/short-circuit protected	Yes/Yes/Yes	
Ambient temperature $T_a$	-25...+70 °C	
Switching frequency $f$ max.	90 Hz	
Output function indicator	Yellow LED	
Degree of protection as per IEC 60529	IP 67	
Approvals	CE	
Material	Housing	PPE
	Sensing surface	PPE
Connection	M12 connector, 4-pin	

Wiring diagrams, see page 958.  
The meaning of switching distance markings can be found on page 962.

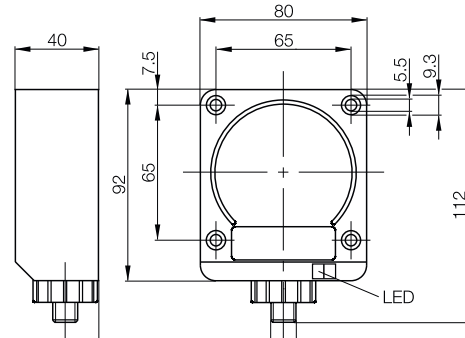

### Maxisensor

Long switching distance with low installation height in the detection direction. Ideal for equipment manufacturing and conveyor technology.

### Permissible Maxisensor installation options

Installation in steel or non-ferrous metals

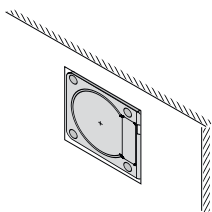

Installation on steel or non-ferrous metals

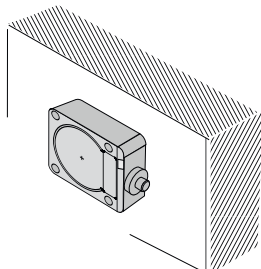

The switching distance is reduced by max. 5.5 mm when not installed flush.



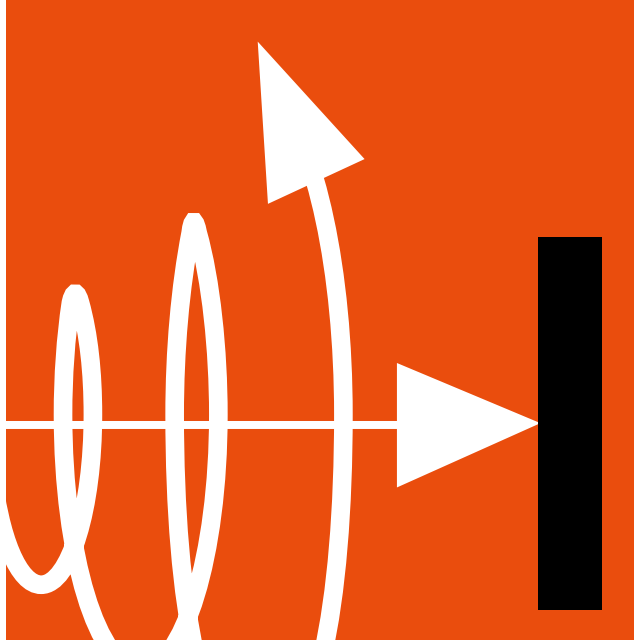

# Inductive Sensors

## AC/DC 2-wire Inductive Sensors

**Our standard product line in the 2-wire version with AC/DC technology:** In this comprehensive product line Balluff offers sensors from M12 to 80x80 mm for virtually every application in the field of automation. These high-quality sensors are designed and manufactured according to worldwide standards and the latest technology. We inspect absolutely every one of our products, providing you the peace of mind that you are receiving only carefully checked sensors.

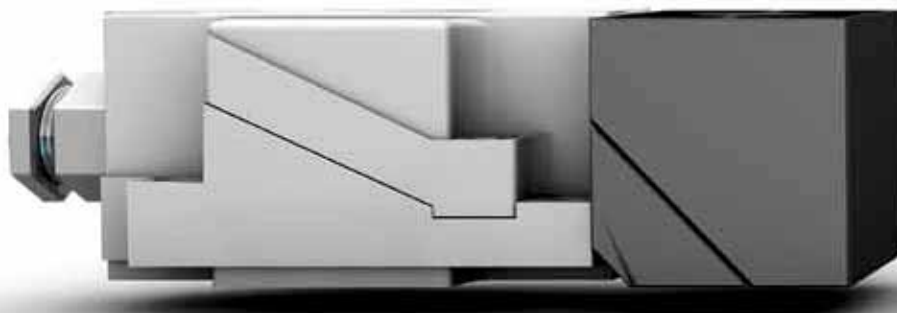

**Cylinder Designs**

M12×1	591
M18×1	592
M30×1.5	595

**Block Designs**

26×40×12 mm (R05)	599
40×73×40 mm (Unicomact)	601
40×120×40 mm (Unisensor)	603
80×80×40 mm (Maxisensor)	607

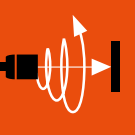

Basic information and definitions can be found on **page 934**.

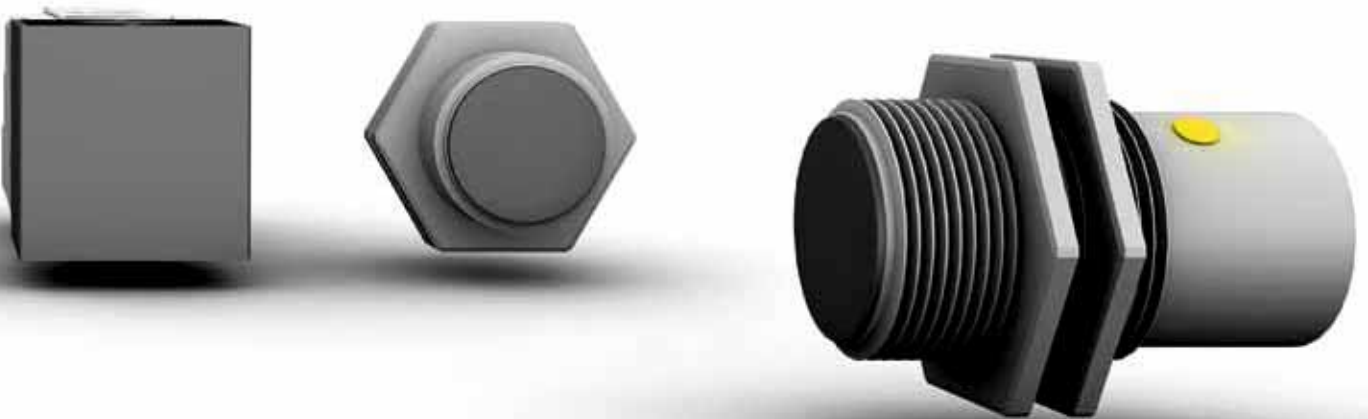



Model	
Installation type (observe instructions in the Basic Information chapter)	
Rated switching distance $s_n$	
Assured switching distance $s_a$	
Switching distance marking	
NO	<b>Ordering code</b>
	Part number
NC	<b>Ordering code</b>
	Part number
Rated operating voltage $U_e$	
Supply voltage $U_S$	
Voltage drop $U_d$ at $I_e$ max.	
Rated insulation voltage $U_i$	
Rated operating current $I_e$	
Minimum operating current $I_m$	
Residual current $I_r$ max.	
Short-term current carrying capacity $I_c$ /time T	
Short-circuit protected	
Ambient temperature $T_a$	
Switching frequency $f$ max.	
Utilization category	
Output function indicator	
Degree of protection as per IEC 60529	
Approvals	
Material	Housing
	Sensing surface
Connection	

**Current reduction as a function of ambient temperature range**

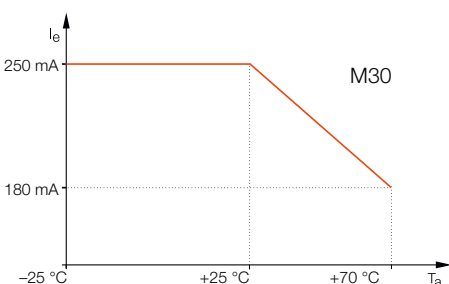
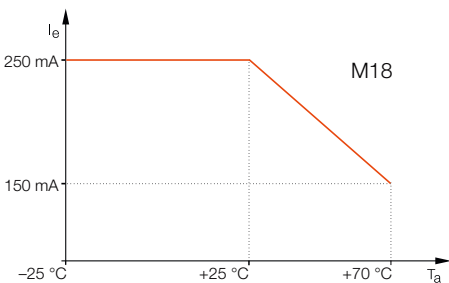
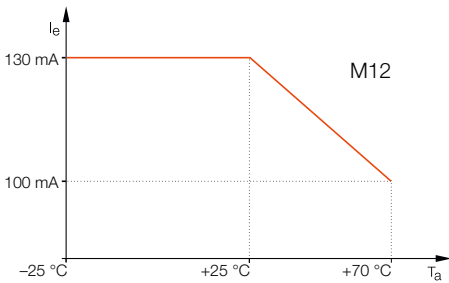

Wiring diagrams, see page 958.

The meaning of switching distance markings can be found on page 962.

**Cable versions (protection class 2) on request.**





M12x1	M12x1	M12x1	M12x1	M12x1
Flush	Flush	Flush	Not flush	Not flush
<b>2 mm</b>	<b>2 mm</b>	<b>2 mm</b>	<b>4 mm</b>	<b>4 mm</b>
0...1.6 mm	0...1.6 mm	0...1.6 mm	0...3.2 mm	0...3.2 mm
■	■	■	■	■
<b>BES027W</b>	<b>BES02E3</b>	<b>BES027Y</b>	<b>BES028C</b>	<b>BES02E4</b>
BES 516-207-S27-E	BES 515-207-S21-E	BES 516-207-S5-E	BES 516-209-S27-E	BES 515-209-S21-E
<b>BES0283</b>		<b>BES0284</b>	<b>BES028K</b>	
BES 516-208-S27-E		BES 516-208-S5-E	BES 516-210-S27-E	
110 V AC	110 V AC	110 V AC	110 V AC	110 V AC
20...250 V AC/DC	20...250 V AC/DC	20...250 V AC/DC	20...250 V AC/DC	20...250 V AC/DC
11 V	11 V	11 V	11 V	11 V
250 V AC	250 V AC	250 V AC	250 V AC	250 V AC
130 mA	130 mA	130 mA	130 mA	130 mA
5 mA	5 mA	5 mA	5 mA	5 mA
1.7 mA	1.7 mA	1.7 mA	1.7 mA	1.7 mA
0.7 A/20 ms	0.7 A/20 ms	0.7 A/20 ms	0.7 A/20 ms	0.7 A/20 ms
Yes	Yes	Yes	Yes	Yes
-25...+70 °C	-25...+70 °C	-25...+70 °C	-25...+70 °C	-25...+70 °C
1 kHz	1 kHz	1 kHz	600 Hz	600 Hz
AC 140/DC 13	AC 140/DC 13	AC 140/DC 13	AC 140/DC 13	AC 140/DC 13
Yellow LED	Yellow LED	Yellow LED	Yellow LED	Yellow LED
IP 67	IP 67	IP 67	IP 67	IP 67
CE, cULus	CE, cULus	CE, cULus	CE, cULus	CE, cULus
Stainless steel	Stainless steel	Stainless steel	Stainless steel	Stainless steel
PA 12	PA 12	PA 12	PA 12	PA 12
M12 connector, 3-pin	1/2" 20UNF-2A plug connector, 3-pin	7/8" 16UN plug connector, 3-pin	M12 connector, 3-pin	1/2" 20UNF-2A plug connector, 3-pin

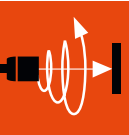

Inductive Sensors  
Global DC 3-wire  
DC 3-/4-wire  
DC 2-wire  
AC/DC 2-wire  
Cylinder Designs  
Block Designs  
AC 2-wire  
Special Properties  
Analog Distance Measurement  
Accessories

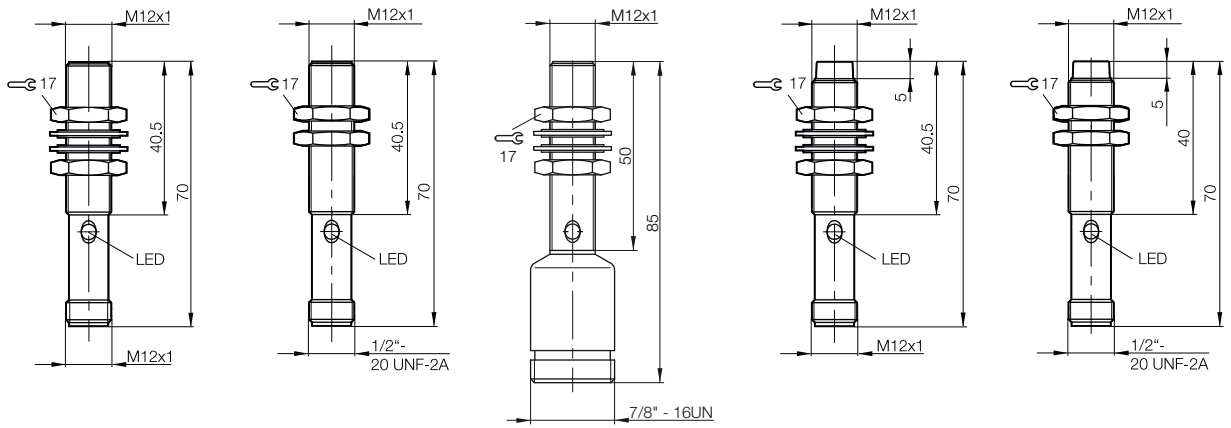

# AC/DC 2-wire Inductive Sensors

## Cylinder design, M12x1, M18x1



Model	M12x1	M12x1	M18x1
Installation type (observe instructions in the Basic Information chapter)	Not flush	Not flush	Flush
Rated switching distance $s_n$	<b>4 mm</b>	<b>8 mm</b>	<b>5 mm</b>
Assured switching distance $s_a$	0...3.2 mm	0...6.4 mm	0...4 mm
Switching distance marking	■	■■	■
NO	<b>Ordering code</b>	<b>BES028E</b>	<b>BES028R</b>
	Part number	BES 516-209-S5-E	BES 516-209-G-S21-E
NC	<b>Ordering code</b>		<b>BES0290</b>
	Part number		BES 516-212-E5-E-S27
Rated operating voltage $U_o$	110 V AC	110 V AC	110 V AC
Supply voltage $U_s$	20...250 V AC/DC	20...250 V AC/DC	20...250 V AC/DC
Voltage drop $U_d$ at $I_o$ max.	11 V	11 V	11 V
Rated insulation voltage $U_i$	250 V AC	250 V AC	250 V AC
Rated operating current $I_o$	130 mA	130 mA	250 mA
Minimum operating current $I_m$	5 mA	5 mA	5 mA
Residual current $I_r$ max.	1.7 mA	1.7 mA	1.7 mA
Short-term current carrying capacity $I_c$ /time T	0.7 A/20 ms	0.7 A/20 ms	1.5 A/20 ms
Short-circuit protected	Yes	Yes	Yes
Ambient temperature $T_a$	-25...+70 °C	-25...+70 °C	-25...+70 °C
Switching frequency $f$ max.	600 Hz	600 Hz	400 Hz
Utilization category	AC 140/DC 13	AC 140/DC 13	AC 140/DC 13
Output function indicator	Yellow LED	Yellow LED	Yellow LED
Degree of protection as per IEC 60529	IP 67	IP 67	IP 67
Approvals	CE, cULus	CE, cULus	CE, cULus
Material	Housing: Stainless steel	Housing: Stainless steel	Housing: Brass-coated
	Sensing surface: PA 12	Sensing surface: PA 12	Sensing surface: PA 12
Connection	7/8" 16UN plug connector, 3-pin	1/2" 20UNF-2A plug connector, 3-pin	M12 connector, 3-pin

Wiring diagrams, see page 958.  
The meaning of switching distance markings can be found on page 962.

**Cable versions (protection class 2) on request.**

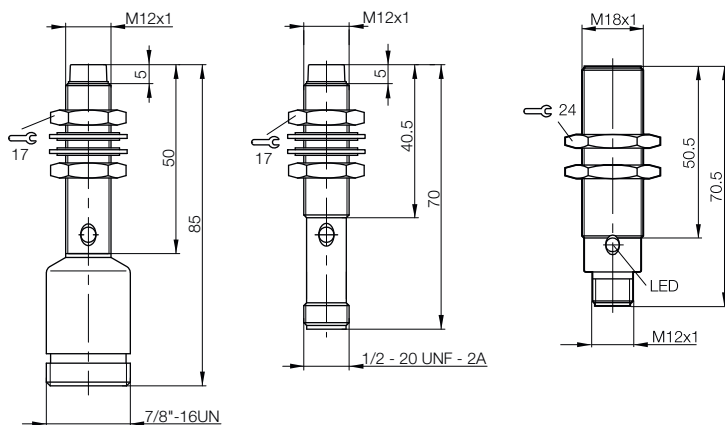

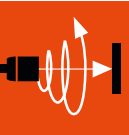

Inductive Sensors  
Global DC 3-wire  
DC 3-/4-wire  
DC 2-wire  
AC/DC 2-wire  
Cylinder Designs  
Block Designs  
AC 2-wire  
Special Properties  
Analog Distance Measurement  
Accessories

M18x1	M18x1	M18x1	M18x1	M18x1
Flush	Flush	Flush	Flush	Flush
<b>5 mm</b>	<b>5 mm</b>	<b>5 mm</b>	<b>5 mm</b>	<b>8 mm</b>
0...4 mm	0...4 mm	0...4 mm	0...4 mm	0...6.4 mm
■	■	■	■	■ ■
<b>BES02E6</b>	<b>BES028P</b>	<b>BES02E5</b>	<b>BES028T</b>	<b>BES02ZE</b>
BES 515-211-E5-E-S27	BES 516-211-E5-E-S21	BES 515-211-E5-E-S21	BES 516-211-E5-E-S5	BES M18MN-USU80B-S21G
	<b>BES028Z</b>		<b>BES0291</b>	
	BES 516-212-E5-E-S21		BES 516-212-E5-E-S5	
110 V AC	110 V AC	110 V AC	110 V AC	110 V AC
20...250 V AC/DC	20...250 V AC/DC	20...250 V AC/DC	20...250 V AC/DC	20...300 V AC/DC
11 V	11 V	11 V	11 V	8 V
250 V AC	250 V AC	250 V AC	250 V AC	250 V AC
250 mA	250 mA	250 mA	250 mA	200 mA
5 mA	5 mA	5 mA	5 mA	4 mA
1.7 mA	1.7 mA	1.7 mA	1.7 mA	0.8 mA
1.5 A/20 ms	1.5 A/20 ms	1.5 A/20 ms	1.5 A/20 ms	1.5 A/20 ms
Yes	Yes	Yes	Yes	Yes
-25...+70 °C	-25...+70 °C	-25...+70 °C	-25...+70 °C	-25...+70 °C
400 Hz	400 Hz	400 Hz	400 Hz	30 Hz
AC 140/DC 13	AC 140/DC 13	AC 140/DC 13	AC 140/DC 13	AC 140/DC 13
Yellow LED	Yellow LED	Yellow LED	Yellow LED	Yellow LED
IP 67	IP 67	IP 67	IP 67	IP 67
CE, cULus	CE, cULus	CE, cULus	CE, cULus	CE, cULus
Stainless steel	Brass-coated	Stainless steel	Brass-coated	Brass-coated
PA 12	PA 12	PA 12	PA 12	PBT
M12 connector, 3-pin	1/2" 20UNF-2A plug connector, 3-pin	1/2" 20UNF-2A plug connector, 3-pin	7/8" 16UN plug connector, 3-pin	1/2" 20UNF-2A plug connector, 3-pin

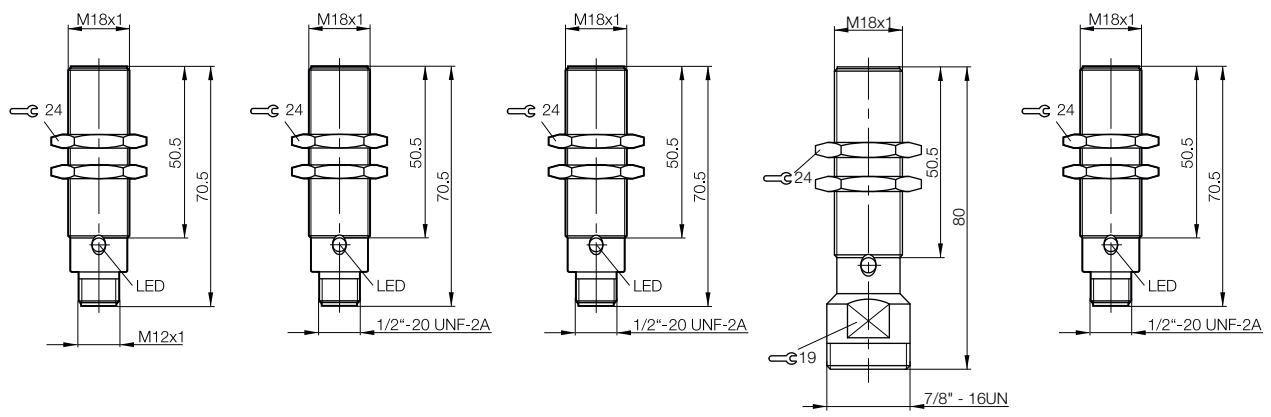

# AC/DC 2-wire Inductive Sensors

## Cylinder designs, M18x1



Model		<b>M18x1</b>	<b>M18x1</b>	<b>M18x1</b>
Installation type (observe instructions in the Basic Information chapter)		Not flush	Not flush	Not flush
Rated switching distance $s_n$		<b>8 mm</b>	<b>8 mm</b>	<b>8 mm</b>
Assured switching distance $s_a$		0...6.4 mm	0...6.4 mm	0...6.4 mm
Switching distance marking		■	■	■
NO	<b>Ordering code</b>	<b>BES0297</b>	<b>BES02E8</b>	<b>BES0296</b>
	Part number	BES 516-213-E5-E-S27	BES 515-213-E5-E-S27	BES 516-213-E5-E-S21
NC	<b>Ordering code</b>	<b>BES029J</b>		<b>BES029H</b>
	Part number	BES 516-214-E5-E-S27		BES 516-214-E5-E-S21
Rated operating voltage $U_o$		110 V AC	110 V AC	110 V AC
Supply voltage $U_s$		20...250 V AC/DC	20...250 V AC/DC	20...250 V AC/DC
Voltage drop $U_d$ at $I_o$ max.		11 V	11 V	11 V
Rated insulation voltage $U_i$		250 V AC	250 V AC	250 V AC
Rated operating current $I_o$		250 mA	250 mA	250 mA
Minimum operating current $I_m$		5 mA	5 mA	5 mA
Residual current $I_r$ max.		1.7 mA	1.7 mA	1.7 mA
Short-term current carrying capacity $I_c$ /time T		1.5 A/20 ms	1.5 A/20 ms	1.5 A/20 ms
Short-circuit protected		Yes	Yes	Yes
Ambient temperature $T_a$		-25...+70 °C	-25...+70 °C	-25...+70 °C
Switching frequency $f$ max.		250 Hz	250 Hz	250 Hz
Utilization category		AC 140/DC 13	AC 140/DC 13	AC 140/DC 13
Output function indicator		Yellow LED	Yellow LED	Yellow LED
Degree of protection as per IEC 60529		IP 67	IP 67	IP 67
Approvals		CE, cULus	CE, cULus	CE, cULus
Material	Housing	Brass-coated	Stainless steel	Brass-coated
	Sensing surface	PA 12	PA 12	PA 12
Connection		M12 connector, 3-pin	M12 connector, 3-pin	1/2" 20UNF-2A plug connector, 3-pin

Wiring diagrams, see page 958.  
The meaning of switching distance markings can be found on page 962.

**Cable versions (protection class 2) on request.**

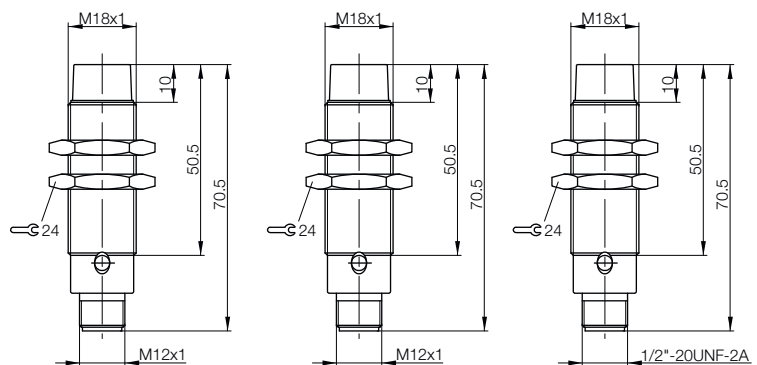



M18x1	M18x1	M18x1	M30x1.5	M30x1.5
Not flush	Not flush	Not flush	Flush	Flush
<b>8 mm</b>	<b>8 mm</b>	<b>16 mm</b>	<b>10 mm</b>	<b>10 mm</b>
0...6.4 mm	0...6.4 mm	0...13 mm	0...8.1 mm	0...8.1 mm
■	■	■ ■	■	■
<b>BES02E7</b>	<b>BES0298</b>	<b>BES029A</b>		<b>BES02EA</b>
BES 515-213-E5-E-S21	BES 516-213-E5-E-S5	BES 516-213-G-E5-E-S21		BES 515-215-E5-E-S27
			<b>BES02A3</b>	
			BES 516-216-E5-E-S27	
110 V AC	110 V AC	110 V AC	110 V AC	110 V AC
20...250 V AC/DC	20...250 V AC/DC	20...250 V AC/DC	20...250 V AC/DC	20...250 V AC/DC
11 V	11 V	11 V	11 V	11 V
250 V AC	250 V AC	250 V AC	250 V AC	250 V AC
250 mA	250 mA	250 mA	250 mA	250 mA
5 mA	5 mA	5 mA	5 mA	5 mA
1.7 mA	1.7 mA	1.7 mA	1.7 mA	1.7 mA
1.5 A/20 ms	1.5 A/20 ms	1.5 A/1 ms	3 A/20 ms	3 A/20 ms
Yes	Yes	Yes	Yes	Yes
-25...+70 °C	-25...+70 °C	-25...+70 °C	-25...+70 °C	-25...+70 °C
250 Hz	250 Hz	250 Hz	150 Hz	150 Hz
AC 140/DC 13	AC 140/DC 13	AC 140/DC 13	AC 140/DC 13	AC 140/DC 13
Yellow LED	Yellow LED	Yellow LED	Yellow LED	Yellow LED
IP 67	IP 67	IP 67	IP 67	IP 67
CE, cULus	CE, cULus	CE, cULus	CE, cULus	CE, cULus
Stainless steel	Brass-coated	Brass-coated	Brass-coated	Stainless steel
PA 12	PA 12	PA 12	PA 12	PA 12
1/2" 20UNF-2A plug connector, 3-pin	7/8" 16UN plug connector, 3-pin	1/2" 20UNF-2A plug connector, 3-pin	M12 connector, 3-pin	M12 connector, 3-pin

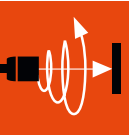

Inductive Sensors  
Global DC 3-wire  
DC 3-/4-wire  
DC 2-wire  
AC/DC 2-wire  
Cylinder Designs  
Block Designs  
AC 2-wire  
Special Properties  
Analog Distance Measurement  
Accessories

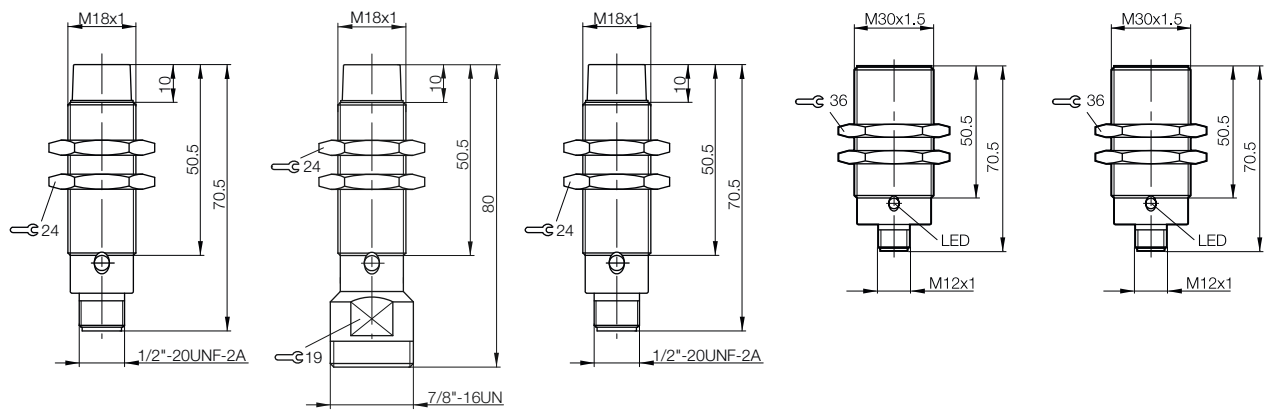

# AC/DC 2-wire Inductive Sensors

## Cylinder designs, M30x1.5



Model	M30x1.5	M30x1.5	M30x1.5
Installation type (observe instructions in the Basic Information chapter)	Flush	Flush	Flush
Rated switching distance $s_n$	<b>10 mm</b>	<b>10 mm</b>	<b>10 mm</b>
Assured switching distance $s_a$	0...8.1 mm	0...8.1 mm	0...8.1 mm
Switching distance marking	■	■	■
NO	<b>Ordering code</b> Part number	<b>BES029T</b> BES 516-215-E5-E-S21	<b>BES029W</b> BES 516-215-E5-E-S5
NC	<b>Ordering code</b> Part number	<b>BES02A2</b> BES 516-216-E5-E-S21	<b>BES02A4</b> BES 516-216-E5-E-S5
Rated operating voltage $U_e$	110 V AC	110 V AC	110 V AC
Supply voltage $U_S$	20...250 V AC/DC	20...250 V AC/DC	20...250 V AC/DC
Voltage drop $U_d$ at $I_e$ max.	11 V	11 V	11 V
Rated insulation voltage $U_i$	250 V AC	250 V AC	250 V AC
Rated operating current $I_e$	250 mA	250 mA	250 mA
Minimum operating current $I_m$	5 mA	5 mA	5 mA
Residual current $I_r$ max.	1.7 mA	1.7 mA	1.7 mA
Short-term current carrying capacity $I_c$ /time T	3 A/20 ms	3 A/20 ms	3 A/20 ms
Short-circuit protected	Yes	Yes	Yes
Ambient temperature $T_a$	-25...+70 °C	-25...+70 °C	-25...+70 °C
Switching frequency $f$ max.	150 Hz	150 Hz	150 Hz
Utilization category	AC 140/DC 13	AC 140/DC 13	AC 140/DC 13
Output function indicator	Yellow LED	Yellow LED	Yellow LED
Degree of protection as per IEC 60529	IP 67	IP 67	IP 67
Approvals	CE, cULus	CE, cULus	CE, cULus
Material	Housing: Brass-coated Sensing surface: PA 12	Stainless steel PA 12	Brass-coated PA 12
Connection	1/2" 20UNF-2A plug connector, 3-pin	1/2" 20UNF-2A plug connector, 3-pin	7/8" 16UN plug connector, 3-pin

Wiring diagrams, see page 958.  
The meaning of switching distance markings can be found on page 962.

**Cable versions (protection class 2) on request.**

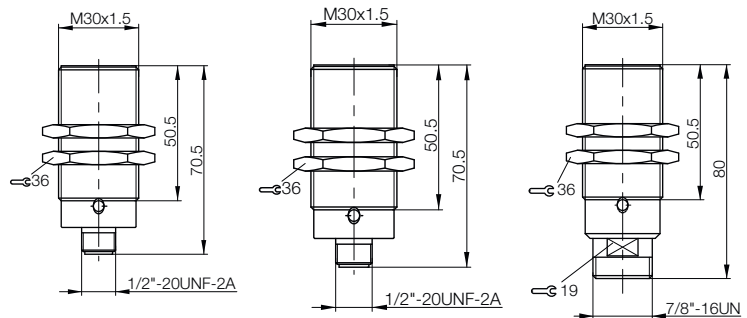

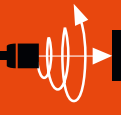

Inductive Sensors

Global DC 3-wire

DC 3-/4-wire

DC 2-wire

AC/DC 2-wire

Cylinder Designs

Block Designs

AC 2-wire

Special Properties

Analog Distance Measurement

Accessories

M30x1.5	M30x1.5	M30x1.5		
Not flush	Not flush	Not flush		
<b>15 mm</b>	<b>15 mm</b>	<b>15 mm</b>		
0...12.1 mm	0...12.1 mm	0...12.1 mm		
■	■	■		
<b>BES02AC</b>	<b>BES02AA</b>	<b>BES02AE</b>		
BES 516-217-E5-E-S27	BES 516-217-E5-E-S21	BES 516-217-E5-E-S5		
<b>BES02AL</b>	<b>BES02AK</b>	<b>BES02AM</b>		
BES 516-218-E5-E-S27	BES 516-218-E5-E-S21	BES 516-218-E5-E-S5		
110 V AC	110 V AC	110 V AC		
20...250 V AC/DC	20...250 V AC/DC	20...250 V AC/DC		
11 V	11 V	11 V		
250 V AC	250 V AC	250 V AC		
250 mA	250 mA	250 mA		
5 mA	5 mA	5 mA		
1.7 mA	1.7 mA	1.7 mA		
3 A/20 ms	3 A/20 ms	3 A/20 ms		
Yes	Yes	Yes		
-25...+70 °C	-25...+70 °C	-25...+70 °C		
100 Hz	100 Hz	100 Hz		
AC 140/DC 13	AC 140/DC 13	AC 140/DC 13		
Yellow LED	Yellow LED	Yellow LED		
IP 67	IP 67	IP 67		
CE, cULus	CE, cULus	CE, cULus		
Brass-coated	Brass-coated	Brass-coated		
PA 12	PA 12	PA 12		
M12 connector, 3-pin	1/2" 20UNF-2A plug connector, 3-pin	7/8" 16UN plug connector, 3-pin		

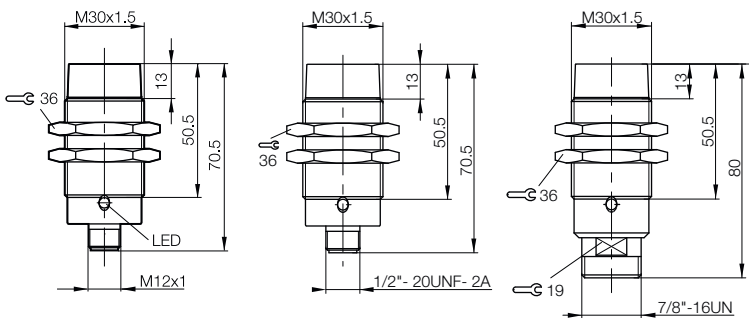

## AC/DC 2-wire Inductive Sensors Sensors in use

**Position detection with inductive sensors BES – for the greatest possible reliability:** In foundry work, exact position detection is absolutely essential for precisely controlled pouring of the metal. Balluff inductive sensors can be integrated into the existing feed system and detect the stationary ladle position right before pouring.



Assembly procedures require precise knowledge about the position of materials. Balluff inductive sensors BES also identify metals over long distances and in harsh environments.





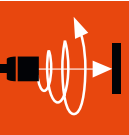

Inductive Sensors  
Global DC 3-wire  
DC 3-/4-wire  
DC 2-wire  
AC/DC 2-wire  
Cylinder Designs  
**Block Designs**  
AC 2-wire  
Special Properties  
Analog Distance Measurement  
Accessories

Model	26×40×12 mm R05	26×40×12 mm R05
Installation type (observe instructions in the Basic Information chapter)	Flush	Flush
Rated switching distance $s_n$	<b>2 mm</b>	<b>4 mm</b>
Assured switching distance $s_a$	0...1.6 mm	0...3.2 mm
Switching distance marking	■	■■
<b>NO</b>	<b>Ordering code</b>	<b>BES02CT</b>
	Part number	BES R05KB-USU20B-EV02
Rated operating voltage $U_o$	110 V AC	110 V AC
Supply voltage $U_s$	20...250 V AC/DC	20...250 V AC/DC
Voltage drop $U_d$ at $I_o$ max.	12 V	12 V
Rated insulation voltage $U_i$ (protection class)	250 V AC (□)	250 V AC (□)
Rated operating current $I_o$	130 mA	130 mA
Minimum operating current $I_m$	5 mA	5 mA
Residual current $I_r$ max.	1.7 mA	1.7 mA
Short-term current carrying capacity $I_c$ /time T	0.7 A/20 ms	0.7 A/20 ms
Short-circuit protected	Yes	Yes
Ambient temperature $T_a$	-25...+70 °C	-25...+70 °C
Switching frequency $f$ max.	400 Hz	400 Hz
Utilization category	AC 140/DC 13	AC 140/DC 13
Output function indicator	Yellow LED	Yellow LED
Degree of protection as per IEC 60529	IP 67	IP 67
Approvals	CE	CE
Material	Housing Sensing surface	PA 12 PA 12
Connection	2 m PVC cable, 2×0.34 mm <sup>2</sup>	2 m PVC cable, 2×0.34 mm <sup>2</sup>

Wiring diagrams, see page 958.  
The meaning of switching distance markings can be found on page 962.

**Additional cable lengths and PUR cable jacket material available on request.**

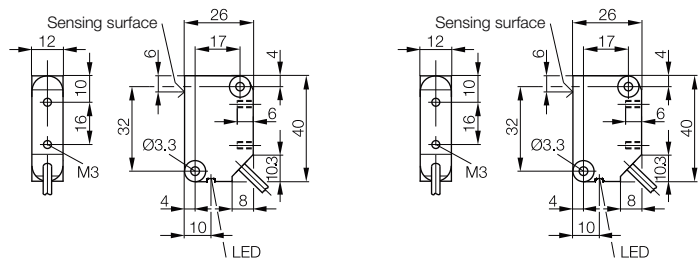

**Row mounting**

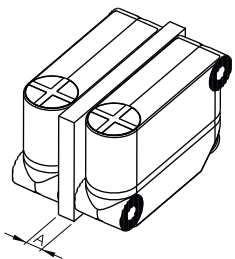

- With plastics or no material present in the space:  
Distance A = at least 5 mm
- With metal in the space:  
Distance A = at least 4 mm

# AC/DC 2-wire Inductive Sensors

## Block designs, 40x73x40 mm

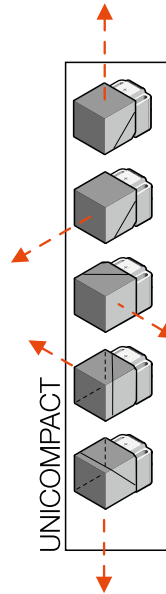

Note permissible installation variants.

Model	
Installation type (observe instructions in the Basic Information chapter)	
Rated switching distance $s_n$	
Assured switching distance $s_a$	
Switching distance marking	
NO	<b>Ordering code</b>
	Part number
NC	<b>Ordering code</b>
	Part number
Rated operating voltage $U_e$	
Supply voltage $U_S$	
Voltage drop $U_d$ at $I_e$ max.	
Rated insulation voltage $U_i$	
Rated operating current $I_e$	
Minimum operating current $I_m$	
Residual current $I_r$ max.	
Short-term current carrying capacity $I_c$ /time T	
Short-circuit protected	
Ambient temperature $T_a$	
Switching frequency $f$ max.	
Utilization category	
Output function indicator	
Degree of protection as per IEC 60529	
Approvals	
Material	Housing
	Sensing surface
Possible installation variations	
Connection	

### Current reduction as a function of ambient temperature range

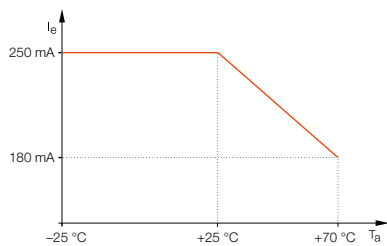

Wiring diagrams, see page 958.

The meaning of switching distance markings can be found on page 962.

### Row mounting

Flush 80 mm, not flush 120 mm

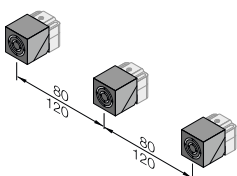

### Installation variations

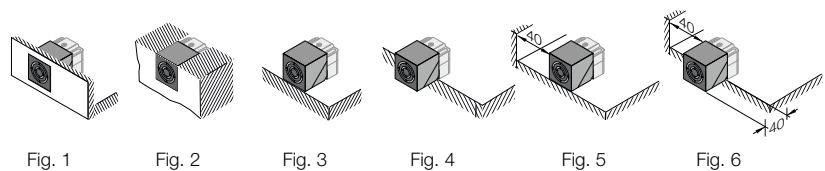

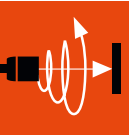

<b>40×73×40 mm</b> Unicomact	<b>40×73×40 mm</b> Unicomact	<b>40×73×40 mm</b> Unicomact	<b>40×73×40 mm</b> Unicomact
Flush	Flush	Not flush	Not flush
<b>15 mm</b>	<b>15 mm</b>	<b>25 mm</b>	<b>25 mm</b>
0...12 mm	0...12 mm	0...20.2 mm	0...20.2 mm
■	■	■	■
<b>BES022E</b>	<b>BES022A</b>	<b>BES022H</b>	<b>BES022F</b>
BES Q40KEU-USU15B-S27G	BES Q40KEU-USU15B-S21G	BES Q40KEU-USU25F-S27G	BES Q40KEU-USU25F-S21G
<b>BES0212</b>	<b>BES0211</b>		<b>BES0213</b>
BES Q40KEU-UOU15B-S27G	BES Q40KEU-UOU15B-S21G		BES Q40KEU-UOU25F-S21G
110 V AC	110 V AC	110 V AC	110 V AC
20...250 V AC/DC	20...250 V AC/DC	20...250 V AC/DC	20...250 V AC/DC
11 V	11 V	11 V	11 V
250 V AC	250 V AC	250 V AC	250 V AC
250 mA	250 mA	250 mA	250 mA
5 mA	5 mA	5 mA	5 mA
1.7 mA	1.7 mA	1.7 mA	1.7 mA
2 A/20 ms	2 A/20 ms	2 A/20 ms	2 A/20 ms
Yes	Yes	Yes	Yes
-25...+70 °C	-25...+70 °C	-25...+70 °C	-25...+70 °C
100 Hz	100 Hz	100 Hz	100 Hz
AC 140/DC 13	AC 140/DC 13	AC 140/DC 13	AC 140/DC 13
Yellow LED	Yellow LED	Yellow LED	Yellow LED
IP 67	IP 67	IP 67	IP 67
CE	CE	CE	CE
PBT/Cast zinc	PBT/Cast zinc	PBT/Cast zinc	PBT/Cast zinc
PBT	PBT	PBT	PBT
Image 1...6	Image 1...6	Image 3...6	Image 3...6
M12 connector, 3-pin	1/2" 20UNF-2A plug connector, 3-pin	M12 connector, 3-pin	1/2" 20UNF-2A plug connector, 3-pin

Inductive Sensors  
Global DC 3-wire  
DC 3-/4-wire  
DC 2-wire  
AC/DC 2-wire  
Cylinder Designs  
**Block Designs**  
AC 2-wire  
Special Properties  
Analog Distance Measurement  
Accessories

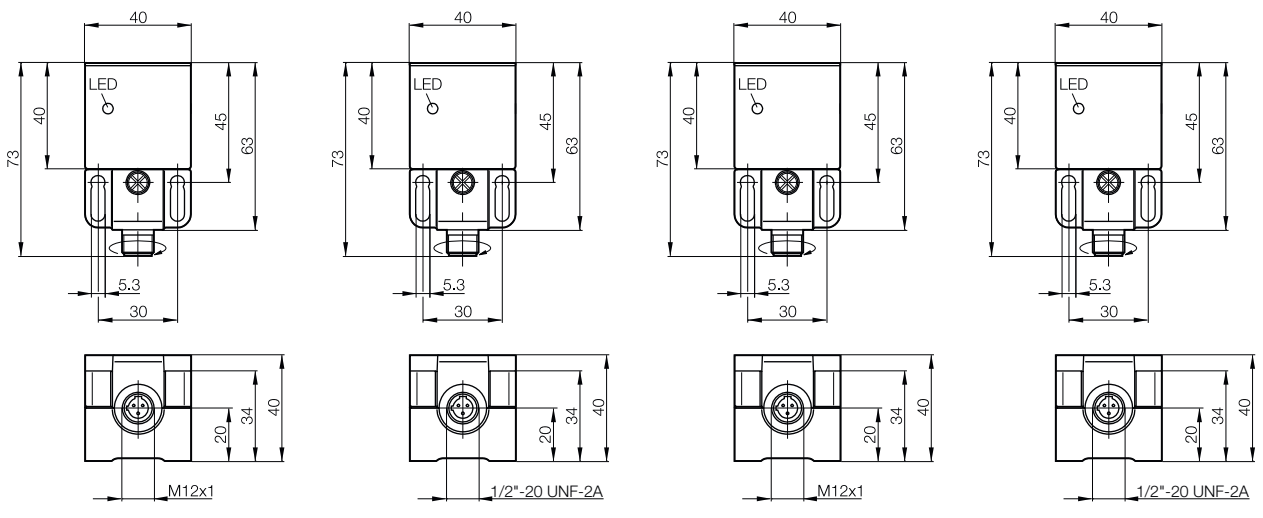

# AC/DC 2-wire Inductive Sensors

## Block designs, 40x120x40 mm

### Programmable Unisensor

Unisensors can be switched between a normally open function- and a normally closed function. A wire jumper is used to change the setting.

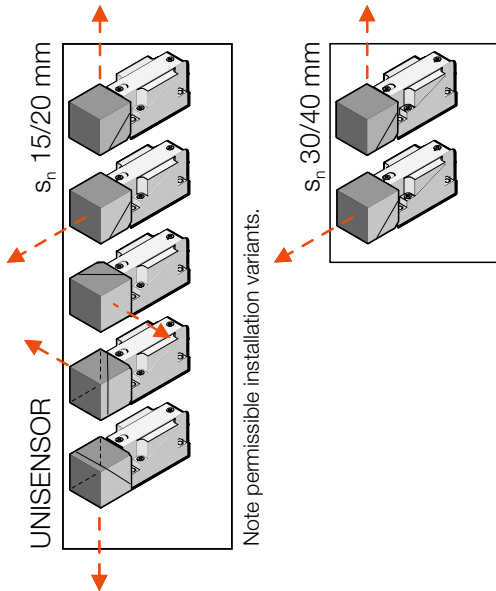

Model	
Installation type (observe instructions in the Basic Information chapter)	
Rated switching distance $s_n$	
Assured switching distance $s_a$	
Switching distance marking	
NO/NC	<b>Ordering code</b>
programmable	Part number
Rated operating voltage $U_o$	
Supply voltage $U_S$	
Voltage drop $U_d$ at $I_o$ max.	
Rated insulation voltage $U_i$ (protection class)	
Rated operating current $I_o$	
Minimum operating current $I_m$	
Residual current $I_r$ max.	
Short-term current carrying capacity $I_c$ /time T	
Short-circuit protected	
Ambient temperature $T_a$	
Switching frequency $f$ max.	
Utilization category	
Output function indicator	
Degree of protection as per IEC 60529	
Approvals	
Material	Housing
	Sensing surface
Possible installation variations	
Connection	

Wiring diagrams, see page 958.  
The meaning of switching distance markings can be found on page 962.

### Current reduction as a function of ambient temperature range

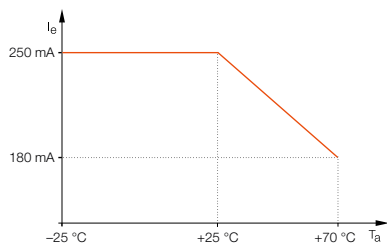

### Row mounting

Flush 80 mm,  
Not flush 120 mm

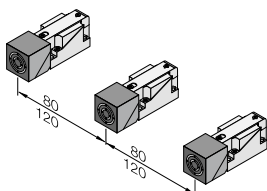

### Installation variations

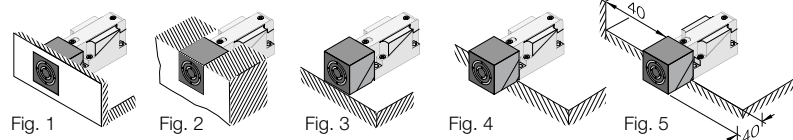

# AC/DC 2-wire Inductive Sensors

## Block designs, 40×120×40 mm



40×120×40 mm Unisensor	40×120×40 mm Unisensor	40×120×40 mm Unisensor
Flush	Flush	Flush
<b>15 mm</b>	<b>15 mm</b>	<b>15 mm</b>
0...12 mm	0...12 mm	0...12 mm
■	■	■
<b>BES020Y</b>	<b>BES0242</b>	<b>BES0243</b>
BES 517-223-M3-E	BES 517-223-U3-E-S21	BES 517-223-U3-E-S5
110 V AC	110 V AC	110 V AC
20...250 V AC/DC	20...250 V AC/DC	20...250 V AC/DC
10.5 V	10.5 V	10.5 V
250 V AC (□)	250 V AC	250 V AC
250 mA	250 mA	250 mA
5 mA	5 mA	5 mA
1.7 mA	1.7 mA	1.7 mA
1 A/20 ms	1 A/20 ms	1 A/20 ms
Yes	Yes	Yes
-25...+70 °C	-25...+70 °C	-25...+70 °C
100 Hz	100 Hz	100 Hz
AC 140/DC 13	AC 140/DC 13	AC 140/DC 13
Yellow LED	Yellow LED	Yellow LED
IP 67	IP 67	IP 67
CE, cULus	CE, cULus	CE, cULus
PBT/aluminum	PBT/aluminum	PBT/aluminum
PBT	PBT	PBT
Image 1...5	Image 1...5	Image 1...5
Screw terminal	1/2" 20UNF-2A plug connector, 3-pin	7/8" 16UN plug connector, 3-pin

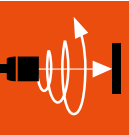

- Inductive Sensors
- Global DC 3-wire
- DC 3-/4-wire
- DC 2-wire
- AC/DC 2-wire
- Cylinder Designs
- Block Designs**
- AC 2-wire
- Special Properties
- Analog Distance Measurement
- Accessories

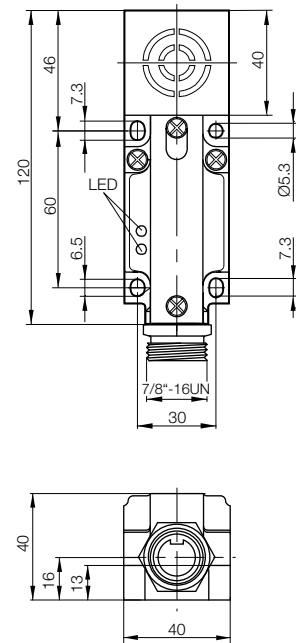
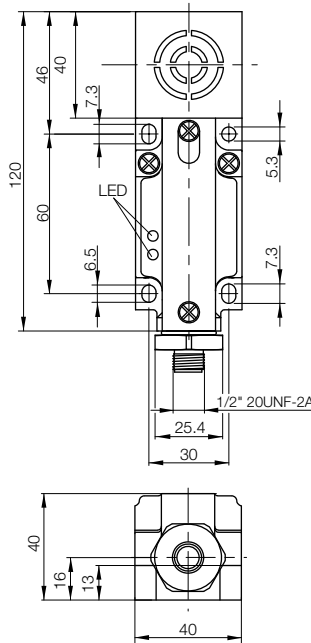
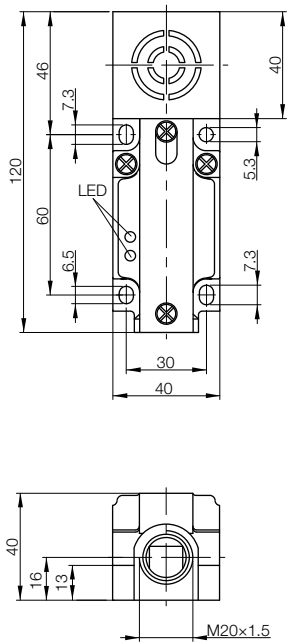

# AC/DC 2-wire Inductive Sensors

## Block designs, 40×120×40 mm



Model	40×120×40 mm Unisensor	40×120×40 mm Unisensor
Installation type (observe instructions in the Basic Information chapter)	Not flush	Not flush
Rated switching distance $s_n$	<b>20 mm</b>	<b>20 mm</b>
Assured switching distance $s_a$	0...16 mm	0...16 mm
Switching distance marking	■	■
<b>NO/NC programmable</b>	<b>Ordering code</b>	<b>BES0245</b>
	Part number	BES 517-223-U4-E-S21
Rated operating voltage $U_o$	110 V AC	110 V AC
Supply voltage $U_s$	20...250 V AC/DC	20...250 V AC/DC
Voltage drop $U_d$ at $I_o$ max.	10.5 V	10.5 V
Rated insulation voltage $U_i$	250 V AC	250 V AC
Rated operating current $I_o$	250 mA	250 mA
Minimum operating current $I_m$	5 mA	5 mA
Residual current $I_r$ max.	1.7 mA	1.7 mA
Short-term current carrying capacity $I_c$ /time T	1 A/20 ms	1 A/20 ms
Short-circuit protected	Yes	Yes
Ambient temperature $T_a$	-25...+70 °C	-25...+70 °C
Switching frequency $f$ max.	100 Hz	100 Hz
Utilization category	AC 140/DC 13	AC 140/DC 13
Output function indicator	Yellow LED	Yellow LED
Degree of protection as per IEC 60529	IP 67	IP 67
Approvals	CE, cULus	CE, cULus
Material	Housing: PBT/aluminum	Housing: PBT/aluminum
	Sensing surface: PBT	Sensing surface: PBT
Possible installation variations	Fig. 4 and 5	Fig. 4 and 5
Connection	1/2" 20UNF-2A plug connector, 3-pin	7/8" 16UN plug connector, 3-pin

Wiring diagrams, see page 958.  
The meaning of switching distance markings can be found on page 962.

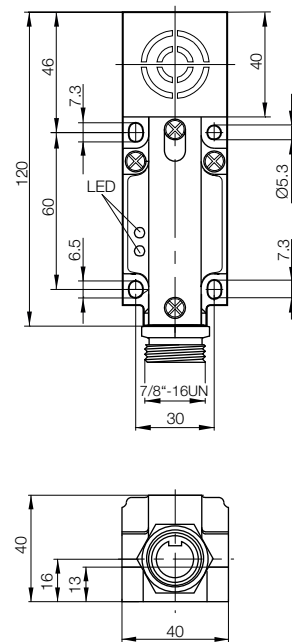
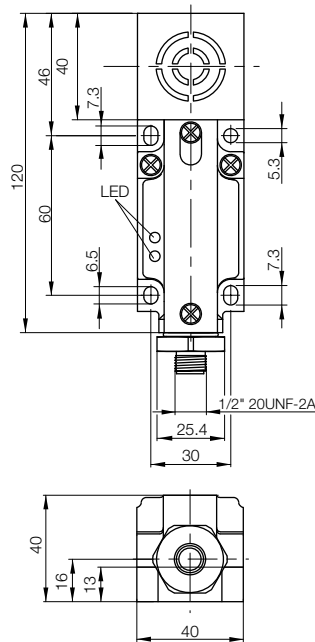

# AC/DC 2-wire Inductive Sensors

## Block designs, 40×120×40 mm

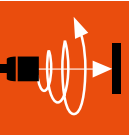

Inductive Sensors  
Global DC 3-wire  
DC 3-/4-wire  
DC 2-wire  
AC/DC 2-wire  
Cylinder Designs  
**Block Designs**  
AC 2-wire  
Special Properties  
Analog Distance Measurement  
Accessories

40×120×40 mm Unisensor	40×120×40 mm Unisensor	40×120×40 mm Unisensor
Not flush	Not flush	Not flush
<b>30 mm</b>	<b>30 mm</b>	<b>40 mm</b>
0...24 mm	0...24 mm	0...32 mm
■	■	■
<b>BES0248</b>	<b>BES0249</b>	<b>BES024C</b>
BES 517-223-U5-E-S21	BES 517-223-U5-E-S5	BES 517-223-U7-EL-S21
110 V AC	110 V AC	110 V AC
20...250 V AC/DC	20...250 V AC/DC	20...250 V
10.5 V	10.5 V	12.5 V
250 V AC	250 V AC	250 V AC
250 mA	250 mA	250 mA
5 mA	5 mA	5 mA
1.7 mA	1.7 mA	1.7 mA
1 A/20 ms	1 A/20 ms	1 A/20 ms
Yes	Yes	Yes
-25...+70 °C	-25...+70 °C	-25...+70 °C
100 Hz	100 Hz	100 Hz
AC 140/DC 13	AC 140/DC 13	AC 140/DC 13
Yellow LED	Yellow LED	Yellow LED
IP 67	IP 67	IP 67
CE, cULus	CE, cULus	CE, cULus
PBT/aluminum	PBT/aluminum	PBT/aluminum
PBT	PBT	PBT
Fig. 4 and 5	Fig. 4 and 5	Fig. 4 and 5
1/2" 20UNF-2A plug connector, 3-pin	7/8" 16UN plug connector, 3-pin	1/2" 20UNF-2A plug connector, 3-pin

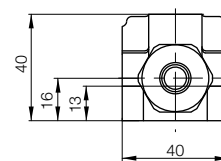
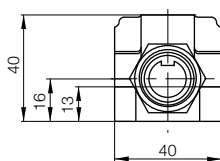
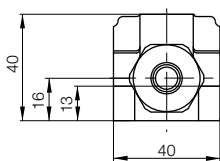
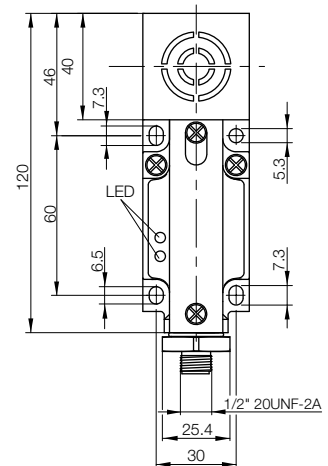
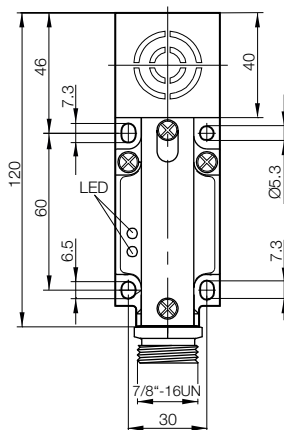
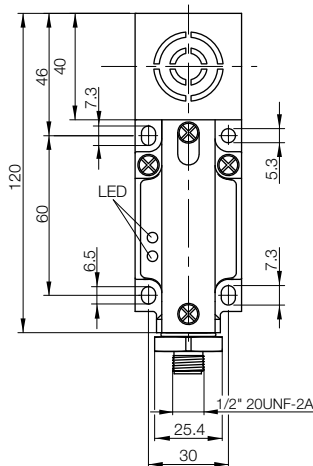

# AC/DC 2-wire Inductive Sensors

## Block designs, 80×80×40 mm



### Precise pallet positioning using inductive sensors BES with long switching distance

Take advantage of the ability to position with precision and ensure a consistent production process. Rugged Maxisensors can be sunk into a plant floor to provide stopping points for vehicle assembly pallets.

### Maxisensor can be programmed

Maxisensors can be set to have a normally open or normally closed function using a switch.

Model	
Installation type (observe instructions in the Basic Information chapter)	
Rated switching distance $s_n$	
Assured switching distance $s_a$	
Switching distance marking	
<b>NO/NC</b>	<b>Ordering code</b>
programmable	Part number
Rated operating voltage $U_o$	
Supply voltage $U_S$	
Voltage drop $U_d$ at $I_o$ max.	
Rated insulation voltage $U_i$ (protection class)	
Rated operating current $I_o$	
Minimum operating current $I_m$	
Residual current $I_r$ max.	
Short-term current carrying capacity $I_c$ /time T	
Short-circuit protected	
Ambient temperature $T_a$	
Switching frequency $f$ max.	
Utilization category	
Output function indicator	
Degree of protection as per IEC 60529	
Approvals	
Material	Housing
	Sensing surface
Connection	

Wiring diagrams, see page 958.  
The meaning of switching distance markings can be found on page 962.

### Mounting in non-ferrous metals

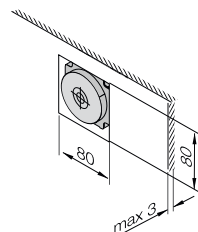

Fig. 1

### Mounting in steel/non-ferrous metals

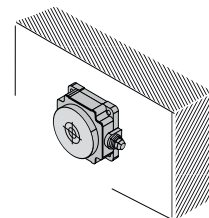

Fig. 2



# AC/DC 2-wire Inductive Sensors

## Block designs, 80×80×40 mm



80×80×40 mm Maxisensor	80×80×40 mm Maxisensor	80×80×40 mm Maxisensor
Not flush	Not flush	Not flush
<b>50 mm</b>	<b>50 mm</b>	<b>50 mm</b>
0...40.5 mm	0...40.5 mm	0...40.5 mm
■	■	■
<b>BES024F</b>	<b>BES023C</b>	<b>BES01ZJ</b>
BES 517-224-M5-E	BES 517-224-M5-E-S21	BES 517-224-U5-E-S5
110 V AC	110 V AC	110 V AC
20...250 V AC/DC	20...250 V AC/DC	20...250 V AC/DC
11 V	11 V	11 V
250 V AC (□)	250 V AC (□)	250 V AC (□)
250 mA	250 mA	250 mA
5 mA	5 mA	5 mA
≤ 1.7 mA	1700 µA	1700 µA
1 A/20 ms	1 A/20 ms	1 A/20 ms
Yes	Yes	Yes
-25...+70 °C	-25...+70 °C	-25...+70 °C
10 Hz	10 Hz	10 Hz
AC 140/DC 13	AC 140/DC 13	AC 140/DC 13
Yellow LED	Yellow LED	Yellow LED
IP 67	IP 67	IP 67
CE, cULus	CE, cULus	CE, cULus
PBT	PBT	PBT
PBT	PBT	PBT
Screw terminals	1/2" 20UNF-2A plug connector, 3-pin	7/8" 16UN plug connector, 3-pin

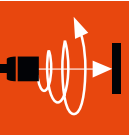

- Inductive Sensors
- Global DC 3-wire
- DC 3-/4-wire
- DC 2-wire
- AC/DC 2-wire
- Cylinder Designs
- Block Designs**
- AC 2-wire
- Special Properties
- Analog Distance Measurement
- Accessories

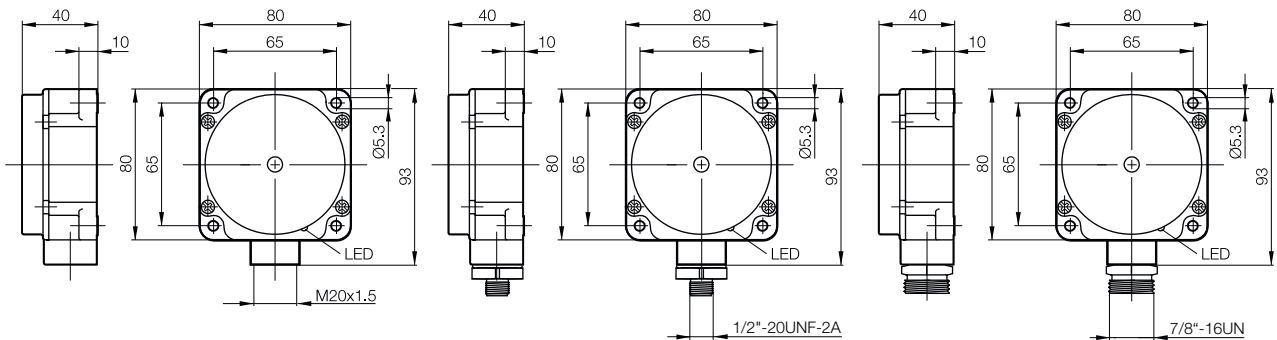

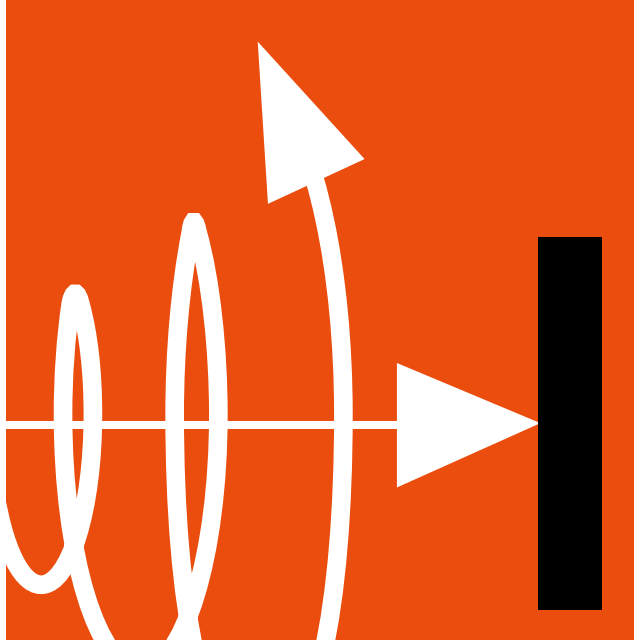

# Inductive Sensors

## AC 2-wire inductive sensors

**Our standard line in 2-wire AC technology:**

Balluff offers AC-sensors in the M12, M18, and M30 design and as Maxisensor series.



**Cylinder Designs**

M12×1	610
M18×1	612
M30×1.5	613

**Block Designs**

80×80×40 mm (Maxisensor)	615
--------------------------	-----

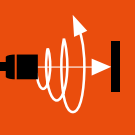

Basic information  
and definitions  
can be found  
on **page 934**.



# AC 2-wire Inductive Sensors

## Cylinder designs, M12x1

AC sensors are optimized for processor units and controllers with alternating current input. These sensors are mainly used in Asia and America. When maintaining the rated operating current, the sensors can directly control fuses and relays.

### Recommendation

Short-circuit protection equipment: Miniature fuse in accordance with IEC 60127-2 Sheet 1,  $\leq 2$  A (fast-acting). See attachment-Circuit diagrams. After a short-circuit, check the device for proper function.



Model		<b>M12x1</b>	
Installation type (observe instructions in the Basic Information chapter)		Flush	
Rated switching distance $s_n$		<b>2 mm</b>	
Assured switching distance $s_a$		0...1.6 mm	
Switching distance marking		■	
NO	<b>Ordering code</b>	<b>BES02CA</b>	
	Part number	BES 516-449-S21-L	
Supply voltage $U_S$		20...250 V AC	
Voltage drop $U_d$ at $I_o$ max.		4 V	
Rated insulation voltage $U_i$ (protection class)		250 V AC (II)	
Rated operating current $I_o$		500 mA	
Polarity reversal/short-circuit protected		Yes/No	
Ambient temperature $T_a$		-25...+70 °C	
Switching frequency $f$ max.		25 Hz	
Utilization category		AC 140	
Function indicator		Yellow LED	
Degree of protection as per IEC 60529		IP 67	
Approvals		CE, cULus	
Material	Housing	Brass-coated	
	Sensing surface	PA 12	
Connection		1/2" 20UNF-2A plug connector, 3-pin	

Wiring diagrams, see page 958.  
The meaning of switching distance markings can be found on page 962.

**Additional cable lengths on request.**

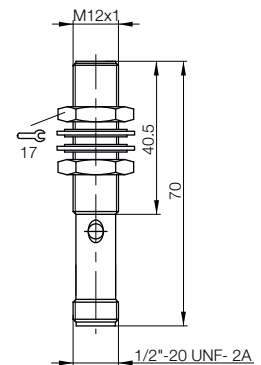



M12x1	M12x1	M12x1	M12x1	M12x1
Flush	Flush	Flush	Not flush	Not flush
<b>2 mm</b>	<b>2 mm</b>	<b>2 mm</b>	<b>4 mm</b>	<b>4 mm</b>
0...1.6 mm	0...1.6 mm	0...1.6 mm	0...3.2 mm	0...3.2 mm
■	■	■	■	■
<b>BES02FP</b>	<b>BES0318</b>	<b>BES02C8</b>	<b>BES02CF</b>	<b>BES02CC</b>
BES 515-449-SA7-S21	BES 516-449-S27-L	BES 516-449-BO-L-02	BES 516-461-S21-L	BES 516-461-BO-L-02
35...250 V AC	20...250 V AC	20...250 V AC	20...250 V AC	20...250 V AC
8.5 V	4 V	4 V	4 V	4 V
250 V AC	250 V AC	250 V AC (□)	250 V AC (□)	250 V AC (□)
150 mA	500 mA	500 mA	500 mA	500 mA
Yes/No	Yes/No	Yes/No	Yes/No	Yes/No
-25...+70 °C	-25...+70 °C	-25...+70 °C	-25...+70 °C	-25...+70 °C
10 Hz	25 Hz	25 Hz	25 Hz	25 Hz
AC 140	AC 140	AC 140	AC 140	AC 140
Yellow LED	Yellow LED	Yellow LED	Yellow LED	Yellow LED
IP 67	IP 67	IP 67	IP 67	IP 67
CE, cULus	CE, cULus	CE, cULus	CE, cULus	CE, cULus
Stainless steel	Brass-coated	Brass-coated	Brass-coated	Brass-coated
PA 12	PA 12	PA 12	PA 12	PA 12
1/2" 20UNF-2A plug connector, 3-pin	M12 connector, 3-pin	2 m PVC cable, 2x0.34 mm <sup>2</sup>	1/2" 20UNF-2A plug connector, 3-pin	2 m PVC cable, 2x0.34 mm <sup>2</sup>

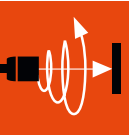

- Inductive Sensors
- Global DC 3-wire
- DC 3-/4-wire
- DC 2-wire
- AC/DC 2-wire
- AC 2-wire
- Cylinder Designs
- Block Designs
- Special Properties
- Analog Distance Measurement
- Accessories

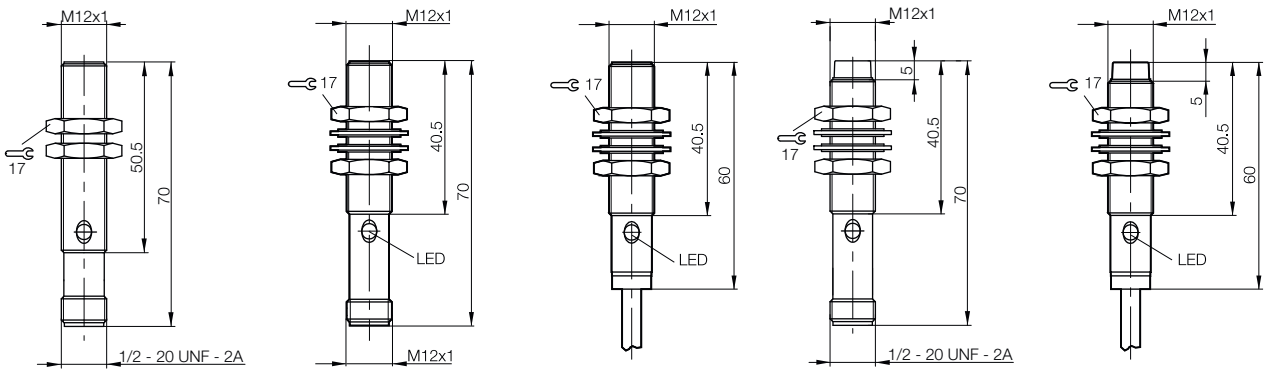

# AC 2-wire Inductive Sensors

## Cylinder designs, M18x1



Model	M18x1	M18x1	M18x1
Installation type (observe instructions in the Basic Information chapter)	Flush	Flush	Flush
Rated switching distance $s_n$	<b>5 mm</b>	<b>5 mm</b>	<b>5 mm</b>
Assured switching distance $s_a$	0...4 mm	0...4 mm	0...4 mm
Switching distance marking	■	■	■
NO	<b>Ordering code</b>	<b>BES0317</b>	<b>BES02AU</b>
	Part number	BES 516-420-E5-L-S27	BES 516-420-E4-L-02
Rated operating voltage $U_o$	110 V	110 V	110 V
Supply voltage $U_s$	20...250 V AC	20...250 V AC	20...250 V AC
Voltage drop $U_d$ at $I_o$ max.	4 V	4 V	4 V
Rated insulation voltage $U_i$ (protection class)	250 V AC (II)	250 V AC	250 V AC (II)
Rated operating current $I_o$	500 mA	500 mA	500 mA
Polarity reversal/short-circuit protected	Yes/No	Yes/No	Yes/No
Ambient temperature $T_a$	-25...+70 °C	-25...+70 °C	-25...+70 °C
Switching frequency $f$ max.	25 Hz	25 Hz	25 Hz
Utilization category	AC 140	AC 140	AC 140
Function indicator	Yellow LED	Yellow LED	Yellow LED
Degree of protection as per IEC 60529	IP 67	IP 67	IP 67
Approvals	CE, cULus	CE, cULus	CE, cULus
Material	Housing: Brass-coated	Brass-coated	Brass-coated
	Sensing surface: PA 12	PA 12	PA 12
Connection	1/2" 20UNF-2A plug connector, 3-pin	M12 connector, 3-pin	2 m PVC cable, 2x0.34 mm <sup>2</sup>

Wiring diagrams, see page 958.  
The meaning of switching distance markings can be found on page 962.

**Additional cable lengths on request.**

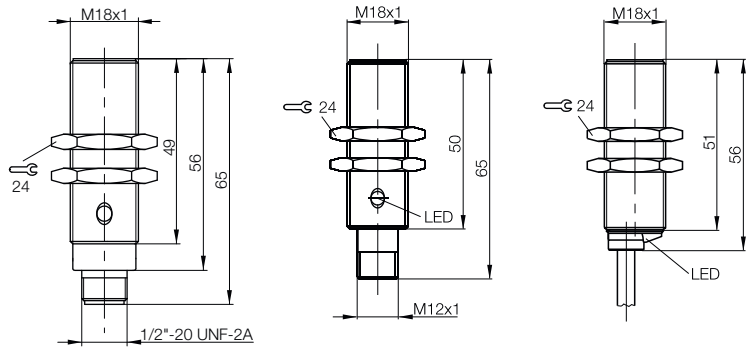

# AC 2-wire Inductive Sensors

## Cylinder designs, M18x1, M30x1.5



M18x1	M18x1	M30x1.5	M30x1.5	M30x1.5
Not flush	Not flush	Flush	Flush	Flush
<b>8 mm</b>	<b>8 mm</b>	<b>10 mm</b>	<b>10 mm</b>	<b>10 mm</b>
0...6.4 mm	0...6.4 mm	0...8 mm	0...8 mm	0...10 mm
■	■	■	■	■
<b>BES02C7</b>	<b>BES02C5</b>	<b>BES02AT</b>	<b>BES0316</b>	<b>BES02AP</b>
BES 516-437-E5-L-S21	BES 516-437-E4-L-02	BES 516-418-E5-L-S21	BES 516-418-E5-L-S27	BES 516-418-E4-L-02
110 V	110 V	110 V	110 V	110 V
20...250 V AC	20...250 V AC	20...250 V AC	20...250 V AC	20...250 V AC
4 V	4 V	4 V	4 V	4 V
250 V AC (□)	250 V AC (□)	250 V AC (□)	250 V AC	250 V AC (□)
500 mA	500 mA	500 mA	500 mA	500 mA
Yes/No	Yes/No	Yes/No	Yes/No	Yes/No
-25...+70 °C	-25...+70 °C	-25...+70 °C	-25...+70 °C	-25...+70 °C
25 Hz	25 Hz	25 Hz	25 Hz	10 Hz
AC 140	AC 140	AC 140	AC 140	AC 140
Yellow LED	Yellow LED	Yellow LED	Yellow LED	Yellow LED
IP 67	IP 67	IP 67	IP 67	IP 67
CE, cULus	CE, cULus	CE, cULus	CE, cULus	CE, cULus
Brass-coated	Brass-coated	Brass-coated	Brass-coated	Brass-coated
PA 12	PA 12	PA 12	PA 12	PA 12
1/2" 20UNF-2A plug connector, 3-pin	2 m PVC cable, 2x0.34 mm <sup>2</sup>	1/2" 20UNF-2A plug connector, 3-pin	M12 connector, 3-pin	2 m PVC cable, 2x0.34 mm <sup>2</sup>

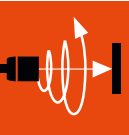

- Inductive Sensors
- Global DC 3-wire
- DC 3-/4-wire
- DC 2-wire
- AC/DC 2-wire
- AC 2-wire
- Cylinder Designs
- Block Designs
- Special Properties
- Analog Distance Measurement

Accessories

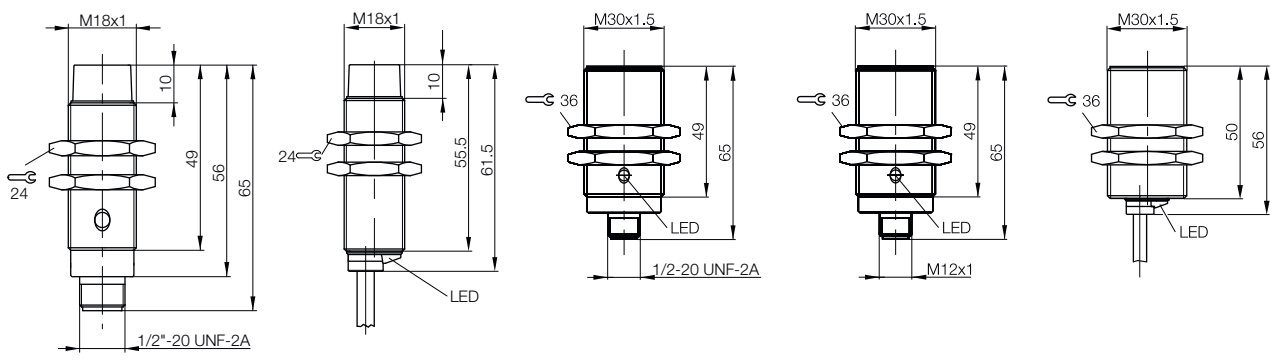

# AC 2-wire Inductive Sensors

## Cylinder designs, M30x1.5



Model		<b>M30x1.5</b>	<b>M30x1.5</b>	
Installation type (observe instructions in the Basic Information chapter)		Not flush	Not flush	
Rated switching distance $s_n$		<b>15 mm</b>	<b>15 mm</b>	
Assured switching distance $s_a$		0...12 mm	0...12 mm	
Switching distance marking		■	■	
NO	<b>Ordering code</b>	<b>BES02C3</b>	<b>BES02C1</b>	
	Part number	BES 516-432-E5-L-S21	BES 516-432-E4-L-02	
Supply voltage $U_S$		20...250 V AC	20...250 V AC	
Voltage drop $U_d$ at $I_e$ max.		4 V	4 V	
Rated insulation voltage $U_i$ (protection class)		250 V AC (□)	250 V AC (□)	
Rated operating current $I_e$		500 mA	500 mA	
Polarity reversal/short-circuit protected		Yes/No	Yes/No	
Ambient temperature $T_a$		-25...+70 °C	-25...+70 °C	
Switching frequency $f$ max.		10 Hz	10 Hz	
Utilization category		AC 140	AC 140	
Function indicator		Yellow LED	Yellow LED	
Degree of protection as per IEC 60529		IP 67	IP 67	
Approvals		CE, cULus	CE, cULus	
Material	Housing	Brass-coated	Brass-coated	
	Sensing surface	PA 12	PA 12	
Connection		1/2" 20UNF-2A plug connector, 3-pin	2 m PVC cable, 2x0.34 mm <sup>2</sup>	

Wiring diagrams, see page 958.  
The meaning of switching distance markings can be found on page 962.

**Additional cable lengths on request.**

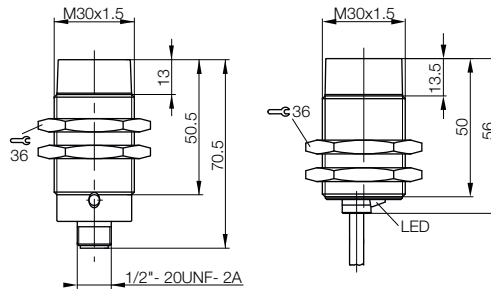



# AC 2-wire Inductive Sensors

## Block designs, 80×80×40 mm



Model	80×80×40 mm Maxisensor	80×80×40 mm Maxisensor
Installation type (observe instructions in the Basic Information chapter)	Not flush	Not flush
Rated switching distance $s_n$	<b>50 mm</b>	<b>50 mm</b>
Assured switching distance $s_a$	0...40 mm	0...40 mm
Switching distance marking	■	■
<b>NO/NC</b>	<b>Ordering code</b>	<b>BES022T</b>
programmable	Part number	BES 517-460-U5-L-D-S21
Supply voltage $U_s$	20...250 V AC	20...250 V AC
Voltage drop $U_d$ at $I_e$ max.	7 V	7 V
Rated insulation voltage $U_i$ (protection class)	250 V AC (□)	250 V AC (□)
Rated operating current $I_e$	500 mA	500 mA
Polarity reversal/short-circuit protected	Yes/No	Yes/No
Ambient temperature $T_a$	-25...+70 °C	-25...+70 °C
Switching frequency $f$ max.	10 Hz	10 Hz
Utilization category	AC 140	AC 140
Function indicator	Yellow LED	Yellow LED
Degree of protection as per IEC 60529	IP 67	IP 67
Approvals	CE, cULus	CE, cULus
Material	Housing: PBT	PBT
	Sensing surface: PBT	PBT
Connection	1/2" 20UNF-2A plug connector, 3-pin	7/8" 16UN plug connector, 3-pin

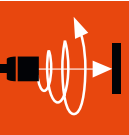

- Inductive Sensors
- Global DC 3-wire
- DC 3-/4-wire
- DC 2-wire
- AC/DC 2-wire
- AC 2-wire
- Cylinder Designs
- Block Designs
- Special Properties
- Analog Distance Measurement
- Accessories

Wiring diagrams, see page 958.  
The meaning of switching distance markings can be found on page 962.

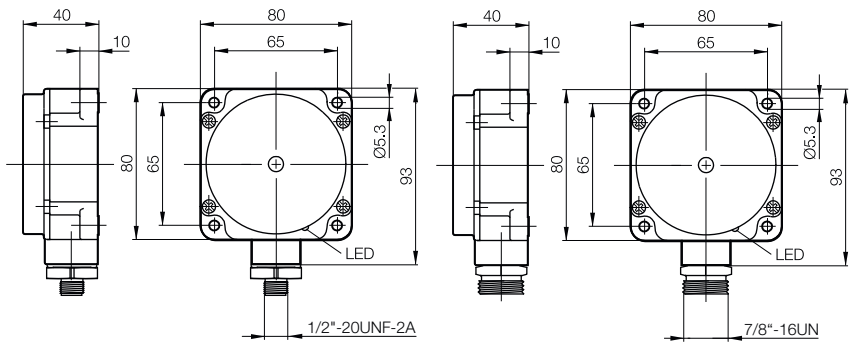

### Maxisensor can be programmed

Maxisensors can be set to have a normally open- or normally closed function using a switch.

### Mounting in non-ferrous metals

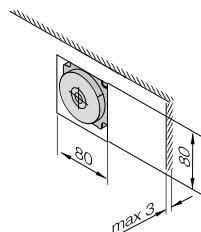

Fig. 1

### Mounting in steel/non-ferrous metals

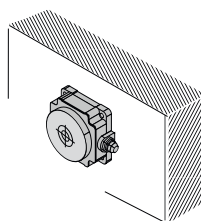

Fig. 2